

Flexible Disc Couplings

TB Wood's Form-Flex®



 Riddhi Engineering Company
www.couplings-mounts.com
sales@riddhiengineeringco.com
+91 74900 32784

*Ameridrives • Bibby Turboflex • Guardian Couplings
Huco • Lamiflex Couplings • TB Wood's*

Table of Contents

Introduction

Product Features and Options	Page 1
Disc Coupling Advantages.....	Page 1
Typical Applications	Page 1
Coupling Application Types.....	Page 2
Coupling Selection Process	Page 3
Coupling Selection Guide	Page 4
Standard Bore Tolerances	Page 5
Industry Standard Reference	Page 6
Dynamic Balance Recommendations	Page 6
Disc Coupling Misalignment Discussion.....	Page 6
Product Differentiation	Page 7
Spacer Couplings	
AP Series - Form-Flex®	Page 9
GP Series - Form-Flex®	Page 10, 11
Floating Shaft Couplings	
A5 Series - Form-Flex®	Page 13
G5 Series - Form-Flex®	Page 14, 15
A5C Series (Composite) - Form-Flex®	Page 16, 17
Closed Coupled Couplings	
AX Series - Form-Flex®	Page 19
AA Series - Form-Flex®	Page 20
AY Series - Form-Flex®	Page 21
Single Flex Couplings	
AR Series - Form-Flex®	Page 23
GR Series - Form-Flex®	Page 24, 25
Heavy Duty Spacer Couplings	
GCH Series - Form-Flex®	Page 27
GCF Series - Form-Flex®	Page 28
HSH Series - Form-Flex®	Page 29
FSH Series - Form-Flex®	Page 30
Coupling Repair Parts and Kits	Page 32, 33
Hub Options.....	Page 34, 35
Design Options.....	Page 36, 37
Bolt Thread Size	Page 38
Bolt/Nut Tightening Torque	Page 38
Application Data Sheet	Page 39, 40



Riddhi Engineering Company

www.couplings-mounts.com

sales@riddhiengineeringco.com

+91 74900 32784

Product Features and Options

Features	TB Wood's Form-Flex					
	A-Series		G-Series			
	AR, AP AX, AY, AA	A5, A6, A7	GP	G5	GR	GCH, GCF, HSH, FSH
Standard Bore Fit:	Clearance		Interference			
Set Screws:	Standard		Optional			
Puller Holes:	Optional					
Standard Flex Disc:	300 Series Stainless Steel ⁽¹⁾					Alloy Steel ⁽²⁾
Balance Class:	AGMA 7	N/A	AGMA 8	N/A	AGMA 7	N/A
Dynamic Balance:	Optional	Per TBW Commercial Standard	Optional	Per TBW Commercial Standard	Optional	N/A

(1) Stainless Steel is standard. Alloy Steel is optional.

(2) Alloy Steel is standard. Stainless Steel is optional.

Form-Flex® Disc Coupling Advantages

- Over 40 years experience in flexible disc couplings
- All metal Construction
- No Lubrication
- No Moving Parts
- Long Life
- High Torsional Stiffness
- Precise Positioning - Zero Backlash

Applications

Flexible Disc couplings can be used in a wide variety of applications from general industrial equipment to high speed precision machines. They are one of the most versatile coupling designs and can be customized to meet the demands of almost every application. Some of the applications in which Flexible Disc couplings can be used are:

- General Purpose
- Centrifugal & Screw Compressors
- Reciprocating Compressors
- Fans & Blowers
- Food Processing
- Machine Tools
- Cooling Towers
- Printing Presses
- Engine & Electric Motor Driven Applications
- Power Generation



Riddhi Engineering Company

www.couplings-mounts.com
sales@riddhiengineeringco.com
+91 74900 32784

Coupling Application Types Table

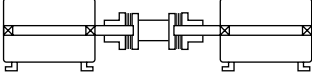
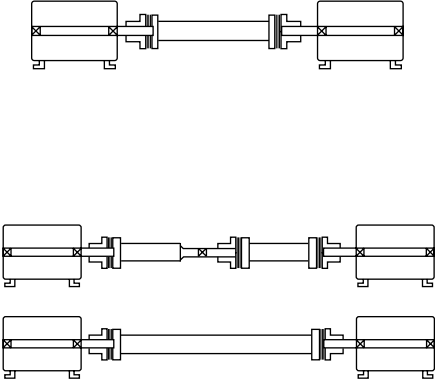
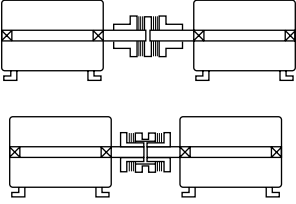
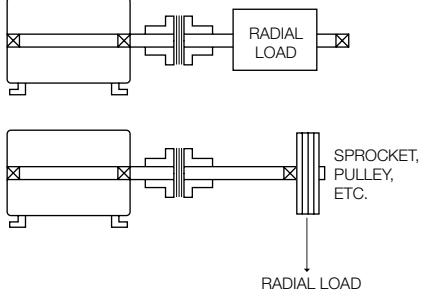
Coupling Type	Typical Applications		Series
<p>Spacer Couplings Double Flex</p>	<p>Spacer couplings are used to connect fully supported shafts with wider separations than can be reached with a close couple design. Spacer couplings allow room for installation and maintenance without moving the connected equipment. Shaft separations are generally in the range of 3 to 12 inches. These couplings accommodate angular, parallel and axial misalignment.</p> 		<p>AP, GP, GCF, GCH, FSH, HSH</p>
<p>Floating Shaft Coupling</p>	<p>Floating shaft couplings are spacer style couplings which are designed to connect widely separated shafts. The coupling spacers are fabricated. Both steel and TrueTube composite tubing options are available.</p> <p>Semi-floating shaft couplings are a special single flex version of the floating shaft coupling. These may be used alone for some applications or in combination with floating shaft couplings and pillow block bearings to span long distances.</p> <p>Composite floating shaft couplings should be considered as an alternative to multiple span applications with center bearings.</p> 		<p>A5, A5C, G5, B5C</p>
<p>Close Couple Double Flex</p>	<p>Close couple designs accommodate angular, parallel and axial misalignment types where two fully supported shafts are located very close together. Close shaft separations are generally in the range of 1/8 to 2 inches.</p> 		<p>AA, AX, AY</p>
<p>Single Flex</p>	<p>Single flexing couplings compensate for angular and axial misalignment only. Single couplings should only be used in a three bearing system with a self-aligning bearing as shown in the illustration. Single couplings may also be used in pairs to support a clutch, transducer or other system component. These arrangements are double flexing and must be used with two fully supported shafts as described below.</p> 		<p>AR, GR</p>



Riddhi Engineering Company

www.couplings-mounts.com
 sales@riddhiengineeringco.com
 +91 74900 32784

Coupling Selection Process

1) Select correct Service Factor (S.F.) from the chart below.

2) Calculate HP/100 RPM or Design Torque (lb-in).

$$\text{HP/100 RPM} = \frac{\text{HP} \times \text{S.F.} \times 100}{\text{coupling RPM}}$$

OR

$$\text{Design Torque (lb-in)} = \frac{63025 \times \text{HP} \times \text{S.F.}}{\text{coupling RPM}}$$

OR

$$\text{Design Torque} = \text{Torque (lb-in)} \times \text{S.F.}$$

Calculate kW/100 RPM or Design Torque (Nm)

$$\text{kW/100RPM} = \frac{\text{kW} \times \text{S.F.} \times 100}{\text{coupling RPM}}$$

$$\text{Design Torque (Nm)} = \frac{9550 \times \text{kW} \times \text{S.F.}}{\text{coupling RPM}}$$

$$\text{Design Torque} = \text{Torque (Nm)} \times \text{S.F.}$$

3) Compare this to the HP/100 RPM (kW/100 RPM) column or the Rated Torque column.

4) Check other limiting factors such as max bores, minimum DBSE, max speed and overall dimensions.

Unit Conversions: HP x .746 = kW or kW x 1.34 = HP
Nm x 8.851 = lb-in or lb-in x .113 = Nm

SERVICE FACTOR TABLE

These service factors assume a smooth motor or turbine type driver. The adders listed for other driver types must be added to the service factor shown for the driven equipment.

Adders For Driver Type		Driven Equipment	S.F.	Driven Equipment	S.F.	Driven Equipment	S.F.
DRIVER	ADD	CONVEYORS-Uniform load (Cont.)		FANS		PAPER MILLS-(Cont.)	
TURBINE	0	Flight	1.25	Centrifugal	1.00	Couch	1.75
AC MOTORS		Oven	1.50	Cooling Tower	2.00	Cutters, Platers	2.00
With Soft Start	0	Screw	1.25	FEEDERS		Cylinders	1.75
NEMA A or B, IEC N	0	CONVEYORS-Non-Uniform Load		Apron	1.25	Dryers	1.75
NEMA C or D, IEC H	1	Apron	1.50	Belt	1.25	Felt Stretchers	1.25
DC MOTORS		Assembly	1.25	Disc	1.25	Felt Whipper	2.00
Shunt Type	0	Belt	1.25	Reciprocating	2.50	Presses	2.00
Series or Compound	1	Bucket	1.50	Screw	1.25	Reel	1.50
I/C ENGINES		Chain	1.50	FOOD INDUSTRY		Stock Chests	1.50
8 or More Cylinders	1	Flight	1.50	Cereal Cookers	1.25	Suction Roll	1.75
4-6 Cylinders	1.5	Oven	1.50	Dough Mixers	1.75	Washers and Thickeners	1.50
1-3 Cylinders	2	Reciprocating	2.50	Meat Grinders	1.75	Winders	1.50
Driven Equipment	S.F.	Screw	1.50	Slicers	1.75	PRINTING PRESSES	1.50
AGITATORS		Shaker	2.50	LUMBER INDUSTRY		PUMPS	
Pure Liquids	1.00	CRANES AND HOISTS		Barkers-Drum Type	2.00	Centrifugal	1.00
Liquids and Solids	1.25	Main Cranes	2.00	Edger Feeders	2.00	Reciprocating	
Liquids-Variable Density	1.25	Reversing	2.00	Live Rolls	2.00	Double Acting	2.00
BLOWERS		Skip Hoists	1.75	Log Haul	2.00	Single Acting 1-2 Cylinders	2.25
Centrifugal	1.00	Trolley Drive	1.75	Off Bearing Rolls	2.00	Single Acting 3+ Cylinders	1.75
Lobe	1.50	Bridge Drive	1.75	Planers	1.75	Rotary-Gear, Lobe, Vane	1.50
Vane	1.25	Slope	1.50	Slab Conveyors	1.50	TEXTILE INDUSTRY	
BRIQUETTER MACHINE	1.00	DREDGES		Sorting Table	1.50	Batchers	1.25
CAN FILLING MACHINE	1.00	Cable Reels	1.75	Trimmer Feed	1.75	Calenders	1.75
COMPRESSORS		Conveyors	1.50	MACHINE TOOLS		Card Machines	1.50
Centrifugal	1.25	Maneuvering Winches	1.75	Bending Roll	2.00	Cloth Finishing Machines	1.50
Lobe	1.50	Pumps	1.75	Plate Planer	1.50	Dry Cans	1.75
Reciprocating	C/F	Screen Drives	1.75	Spindle Drives	1.50	Dryers	1.50
CONVEYORS-Uniform Load		Stracers	1.75	Table/Axis Drives	1.25	Dyeing Machinery	1.25
Apron	1.25	Utility Winches	1.50	Tapping Machines	2.50	Looms	1.50
Assembly	1.00	ELEVATORS		PAPER MILLS		Mangles	1.25
Belt	1.00	Bucket	1.75	Beater & Pulper	1.75	Nappers	1.25
Bucket	1.25	Centrifugal Discharge	1.50	Bleacher	1.00	Soapers	1.25
Chain	1.25	Freight	2.00	Calendars	2.00	Spinners	1.50
		Gravity Discharge	1.50	Converting Machines	1.50	Tinter Frames	1.50



Riddhi Engineering Company

www.couplings-mounts.com
sales@riddhiengineeringco.com
+91 74900 32784

Coupling Selection Guide

- 1) Consult factory for applications in shaded areas.
- 2) Torque ratings may vary by coupling series.
- 3) Use the 1.0 service factor column if a service factor was used in the HP/100 RPM kW/100 RPM calculation.

Typical Application Conditions						
SMOOTH MOTOR OR TURBINE DRIVEN	STEADY MOTOR OR TURBINE DRIVEN	MODERATE MOTOR OR TURBINE DRIVEN	MEDIUM MOTOR OR TURBINE DRIVEN	HEAVY-HIGH TQ. MOTOR OR ENGINE DRIVEN	EXTRA HEAVY ENGINE DRIVEN	EXTREMELY HEAVY ENGINE DRIVEN
SOFT START WITH STEADY LOAD	AVERAGE STARTING LOADS AND SLIGHT TORQUE VARIATIONS	ABOVE AVERAGE STARTING LOADS AND MODERATE LOAD VARIATIONS	HIGH STARTING TORQUES AND MEDIUM TO HEAVY LOAD VARIATIONS	MILD SHOCK LOADING ENGINES DRIVING SMOOTH LOADS. EXTREME RELIABILITY	HEAVY SHOCK LOADING OR LIGHT REVERSING	EXTREME SHOCK LOADING. FREQUENT WIDE TORQUE VARIATIONS

Consult Altra Couplings Engineering

Not Recommended for these Applications

Type/Size	Torque Rating				O.D. (in)	Service Factor							# of Bolts
	HP / 100 RPM	Max Continuous (lb-in)	Peak Overload (lb-in)	Rated HP/100 RPM at Service Factor Shown									
				1.0		1.5	2.0	2.5	3.0	3.25	4.0		
Form-Flex® A-Series	05	0.48	300	600	2.65	0.48	0.32	0.24	0.19				4
	10	1.27	800	1,600	3.19	1.27	0.85	0.63	0.51				
	15	2.50	1,575	3,150	3.65	2.50	1.67	1.25	1.00				
	20	3.49	2,200	4,400	4.08	3.49	2.33	1.75	1.40				
	25	6.03	3,800	7,600	4.95	6.03	4.02	3.01	2.41				
	30	11.00	6,930	13,860	5.63	11.00	7.33	5.50	4.40				
	35	18.00	11,340	22,680	6.63	17.99	12.00	9.00	7.20				
Form-Flex® G-Series	311	17.5	11,000	22,000	5.88	17.45	11.64	8.73	6.98	5.8	5.4	6	
	321	32.5	20,500	41,000	6.38	32.53	21.68	16.3	13.0	10.8	10		
	332	50.8	32,000	64,000	7.20	50.8	33.8	25	20	17	16		
	346	73.0	46,000	92,000	8.20	73.0	48.7	36	29	24	22		
	380	127	80,000	160,000	9.36	127	85	63	51	42	39		
	340	63.5	40,000	80,000	8.38	63.5	42.3	32	25	21	20	16	8
	412	190	120,000	240,000	11.00	190	127	95	76	63	59	48	
	419	301	190,000	380,000	12.50	301	201	151	121	100	93	75	
	424	476	300,000	600,000	15.00	476	317	238	190	159	146	119	
	444	690	435,000	870,000	16.38	690	460	345	276	230	212	173	
	456	889	560,000	1,120,000	18.00	889	592	444	355	296	273	222	
	483	1317	830,000	1,660,000	19.44	1317	878	658	527	439	405	329	
	511	1745	1,100,000	2,200,000	22.00	1745	1164	873	698	582	537	436	
	520	3173	2,000,000	4,000,000	24.88	3173	2116	1587	1269	1058	976	793	
	525	3967	2,500,000	5,000,000	26.75	3967	2644	1983	1587	1322	1221	992	
530	4760	3,000,000	6,000,000	28.00	4760	3173	2380	1904	1587	1465	1190		
540	6347	4,000,000	8,000,000	33.50	6347	4231	3173	2539	2116	1953	1587		
Form-Flex® (HSH/FSH)	22	15.1	9,500	14,250	6.00	15.07	10.05	7.54	6.03	5.02	4.64	3.8	8
	26	25.4	16,000	24,000	6.87	25.39	16.9	12.7	10.2	8.5	7.8	6	
	31	38.1	24,000	36,000	8.12	38.08	25	19.0	15.2	13	12	10	
	35	69.8	44,000	66,000	9.12	69.8	47	35	28	23	21	17	
	37	95.2	60,000	90,000	10.06	95.2	63	48	38	32	29	24	
	42	116	73,000	109,500	11.00	116	77	58	46	39	36	29	
	45	157	99,000	148,500	11.44	157	105	79	63	52	48	39	
	50	203	128,000	192,000	13.00	203	135	102	81	68	62	51	
	55	300	189,000	283,500	15.00	300	200	150	120	100	92	75	
	60	414	261,000	391,500	16.00	414	276	207	166	138	127	104	
	70	658	415,000	622,500	18.50	658	439	329	263	219	203	165	
	75	846	533,000	799,500	20.00	846	564	423	338	282	260	211	
	80	1087	685,000	1,027,500	22.00	1087	725	543	435	362	334	272	
	85	1315	829,000	1,243,500	23.75	1315	877	658	526	438	405	329	
	92	1650	1,040,000	1,560,000	25.75	1650	1100	825	660	550	508	413	
	92HT	2221	1,400,000	2,100,000	25.75	2221	1481	1111	889	740	683	555	



Riddhi Engineering Company

www.couplings-mounts.com
sales@riddhiengineeringco.com
+91 74900 32784

Standard Bore Tolerances

Metric Standard Bore and Keyway Info

Recommended Bore Tolerance for Metric Shafts (mm)

Nominal Shaft Range		Shaft Tol.	Shaft Des.	Clearance Fit		Interference Fit	
Over	To (Incl.)			Bore Tol.	Bore Des.	Bore Tol.	Bore Des.
12	18	+0.008 / -0.003	j6	+0.016 / +0.034	F7	-0.015 / -0.004	M6
19	30	+0.009 / -0.004		+0.020 / +0.041	F7	-0.017 / -0.004	M6
32	50	+0.018 / +0.002	k6	+0.025 / +0.050	F7	-0.013 / +0.003	K6
55	80	+0.030 / +0.011	m6	+0.030 / +0.060	F7	-0.021 / +0.009	K7
85	100	+0.035 / +0.013		+0.036 / +0.071	F7	-0.035 / +0.000	M7
110	120	+0.035 / +0.013				-0.059 / -0.024	P7
125	180	+0.040 / +0.015		+0.043 / +0.083	F7	-0.068 / -0.028	P7
190	200	+0.046 / +0.017		+0.050 / +0.096	F7	-0.079 / -0.033	P7
210	225					-0.109 / -0.063	R7
230	250					-0.113 / -0.067	R7
260	280					+0.052 / +0.020	+0.056 / +0.108

Reference AGMA 9112-A04

Recommended Hub Keyway Dimensions (mm)

Nominal Bore Range		Nominal Key Size	Hub Keyway	
Over	To (Incl.)		Width	Depth
		Nominal		Nominal
10	12	4X4	4	1.8
12	17	5X5	5	2.3
17	22	6X6	6	2.8
22	30	8X7	8	3.3
30	38	10X8	10	3.3
38	44	12X8	12	3.3
44	50	14X9	14	3.8
50	58	16X10	16	4.3
58	65	18X11	18	4.4
65	75	20X12	20	4.9
75	85	22X14	22	5.4
85	95	25X15	25	5.4
95	110	28X16	28	6.4
110	130	32X18	32	7.4
130	150	36X20	36	8.4
150	170	40X22	40	9.4
170	200	45X25	45	10.4
200	230	50X28	50	11.4
230	260	56X32	56	12.4
260	290	63X32	63	12.4

Standard metric keyway width tolerance per Js9

Imperial Standard Bore and Keyway Info

Recommended Bore Tolerance for Imperial Shafts (Inches)

Nominal Shaft Range		Shaft Tol.	Interference Fit Bore Tol.	Clearance Fit Bore Tol.
Over	To (Incl.)			
.4375	1.5	+0.0000 / -0.0005	-0.0005 / -0.0010	+0.0010 / -0.0000
1.5	2	+0.0000 / -0.0010	-0.0010 / -0.0020	+0.0010 / -0.0000
2	3		-0.0010 / -0.0020	+0.0015 / -0.0000
3	4		-0.0015 / -0.0030	
4	5		-0.0020 / -0.0035	
5	7		-0.0025 / -0.0040	
7	8		-0.0030 / -0.0050	N/A
8	9		-0.0035 / -0.0055	N/A
9	10		-0.0040 / -0.0060	N/A

Reference AGMA 9002-B04

Recommended Hub Keyway Dimensions (Inches)

Nominal Bore Range		Key Dims.		
Over	To (Incl.)	Width	Depth Square Key	Depth Reduced Key
0.312	0.438	0.094	0.047	-
0.438	0.562	0.125	0.063	0.047
0.562	0.875	0.188	0.094	0.062
0.875	1.250	0.25	0.125	0.094
1.250	1.375	0.312	0.156	0.125
1.375	1.750	0.375	0.188	0.125
1.750	2.250	0.500	0.250	0.188
2.250	2.750	0.625	0.313	0.219
2.750	3.250	0.750	0.375	0.250
3.250	3.750	0.875	0.438	0.313
3.750	4.500	1.000	0.500	0.375
4.500	5.500	1.250	0.625	0.438
5.500	6.500	1.500	0.750	0.500
6.500	7.500	1.750	0.875	0.750
7.500	9.000	2.000	1.000	0.750
9.000	11.000	2.500	1.250	0.875

Standard keyway fit is Commercial Class per AGMA 9002-B04

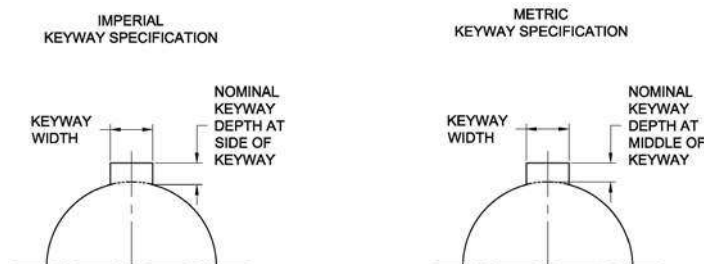

Riddhi Engineering Company

www.couplings-mounts.com

sales@riddhiengineeringco.com

+91 74900 32784

INDUSTRY STANDARDS REFERENCED

AGMA 9002-B04 - BORES AND KEYWAYS FOR FLEXIBLE COUPLINGS (INCH SERIES)
 AGMA 9112-A04 - BORES AND KEYWAYS FOR FLEXIBLE COUPLINGS (METRIC SERIES)
 AGMA 922-A96 - LOAD CLASSIFICATION AND SERVICE FACTORS FOR FLEXIBLE COUPLINGS
 API610 / ISO 13709 - CENTRIFUGAL PUMPS FOR PETROLEUM, PETROCHEMICAL AND NATURAL GAS INDUSTRY, 11th Edition
 API671 / ISO 10441 - SPECIAL PURPOSE COUPLINGS FOR PETROLEUM, CHEMICAL AND GAS INDUSTRY SERVICES, 4th Edition
 NEMA MG1 14.38, MG1 20.81 AND MG1 21.82 - All Form-Flex® flexible disc couplings meet these standards without the addition of a limited end float device.

Certain tables and data in this catalog were extracted from the reference AGMA standards with the permission of the publisher, the American Gear Manufacturers Associations, 1901 North Meyer Drive, Arlington, VA 22209.

DYNAMIC BALANCING RECOMMENDATIONS

Use this graph to determine the appropriate balance class based on coupling weight and operating speed. The balance classes listed on the graph are for equipment with average sensitivity to coupling unbalance. The user should determine how sensitive the equipment train is to coupling unbalance. Use one balance class higher if your system has higher than average sensitivity to unbalance. Use one balance class lower if your system has lower than average sensitivity to unbalance. Use this guide to check your coupling selection against the recommended balance class for your operating conditions.

The following factors should be considered when determining a machine's sensitivity to coupling unbalance.

- 1) Shaft End Deflection: Machines having flexible shaft extensions are relatively sensitive to coupling unbalance.
- 2) Bearing Load Due to Coupling Weight Relative to Total Bearing Load: Machines having lightly loaded bearings, bearings that are primarily loaded by the weight of the coupling or other overhung weight are relatively sensitive to coupling unbalance.
- 3) Bearing, Bearing Support and Foundation Flexibility: Machines or systems with flexible foundations for supports for the rotating elements are relatively sensitive to coupling unbalance.
- 4) System Natural Frequencies: Machines operating at or near natural frequencies are sensitive to coupling unbalance.
- 5) Machine Separation: System having widely separated machines are relatively sensitive to coupling unbalance.
- 6) Shaft Extension Relative to Bearing Span: Machines having a short bearing span relative to their shaft extensions are sensitive to static unbalance.

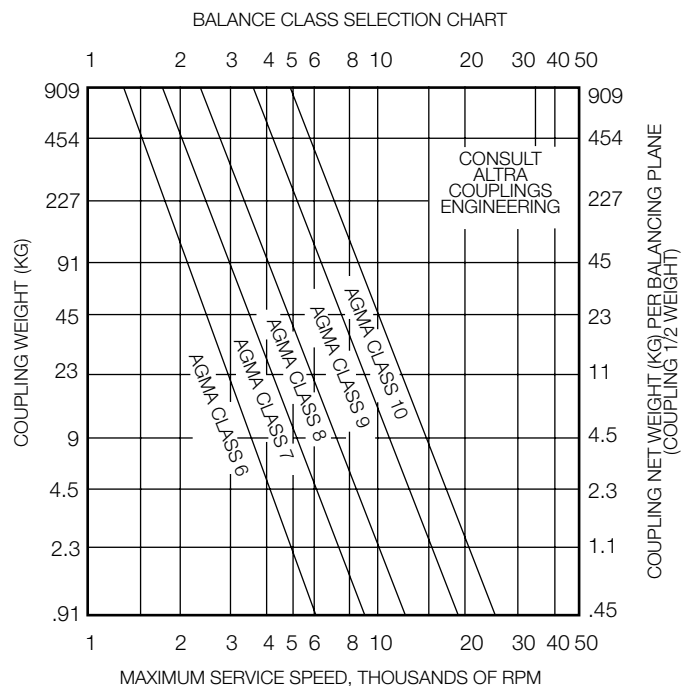

HOW FLEXIBLE DISC COUPLINGS ACCOMMODATE

MISALIGNMENT

Double flexing metal disc couplings may be used to accommodate angular, parallel and axial misalignment. Single flexing couplings may only be used to accommodate angular and axial misalignment. A metal disc type coupling uses a double hinge effect through two flexible discs and the spacer to compensate for parallel offset misalignment between shafts. Parallel misalignment imposes the same angular deflection (A) on each flex disc. Angular misalignment of either connected shaft, (B), creates additional angular deflections which are added to the angular offset due to parallel misalignment. The total misalignment angle, (C), at the flex disc is equal to the angular offset due to parallel misalignment (A) plus the angular offset due to angular misalignment (B). The maximum misalignment angle (C) should never exceed the rated misalignment capacity of the coupling type being used. Machinery equipment changes in actual operation and over the life of the equipment. We recommend that the machinery misalignment be set as close to zero as possible when a coupling is installed. We recommend keeping the measured misalignment below 25% of the rated misalignment capacity of the coupling type used when the machinery is installed and aligned. The remaining coupling misalignment capacity will then be available to accommodate additional misalignment caused by foundation shifts, vibrations, thermal growth or other causes.

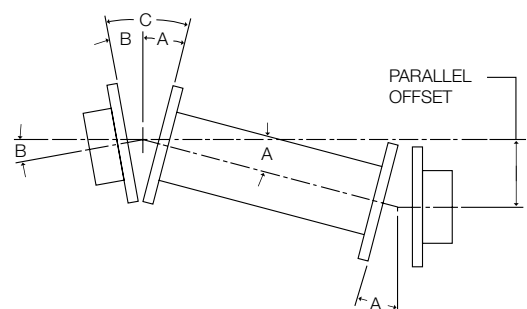

Form-Flex® A - Series	Form-Flex® G - Series
Higher bore capacity in low torque range	Higher Torque Density
1 ° Misalignment	.3 - .5 ° Misalignment
Clearance Fit is standard	Interference Fit is standard
AGMA 7 balance class	AGMA 8 balance class
Non-Unitized Flex Pack	Unitized Flex Pack
ATEX Group II/ Cat 3	ATEX Group II/ Cat 3
Low to Moderate Speeds	Low to Moderate Speeds

DISC PACK DESIGN COMPARISON

**Form-Flex® G-Series
Sizes 311-380**

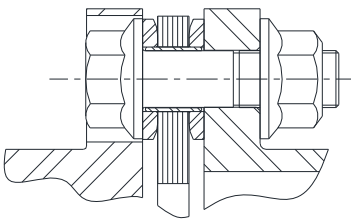

UNITIZED

- Disc pack force transferred to washer & hub interface
- Low bolt bending stress
- All torque transmitted through friction
- Higher torque capacity

**Form-Flex® G-Series
Sizes 340 & 412-511**

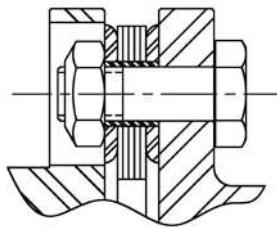

**Form-Flex® G-Series
Sizes 517-540**

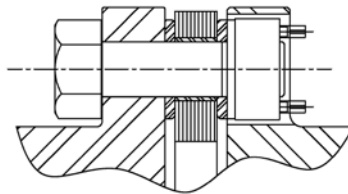

**Form-Flex®
A-Series
Sizes 5-35**

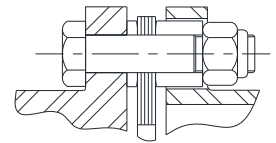

**Form-Flex®
HSH/FSH**

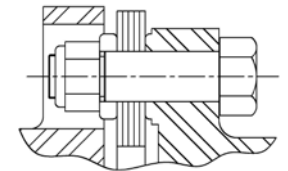

NON-UNITIZED

- Disc pack creates a bending moment on bolt
- High bolt bending stress
- Torque transmitted through shear and friction
- Lower torque capacity

UNITIZED DISC DESIGNS

**Form-Flex®
G-Series, Sizes 311-380
(excluding 340)**

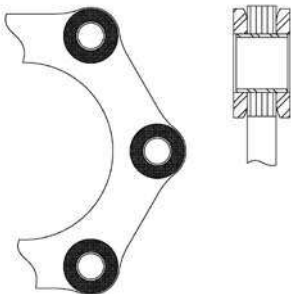

**Form-Flex®
G-Series, Sizes 340 & 412-540**

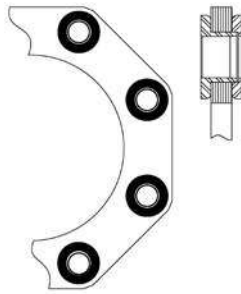

NON-UNITIZED DISC DESIGNS

**Form-Flex®
A-Series sizes 5-35**

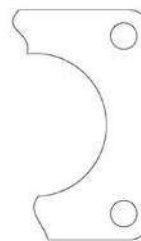

**Form-Flex®
HSH/FSH**



Riddhi Engineering Company

www.couplings-mounts.com

sales@riddhiengineeringco.com

+91 74900 32784

Spacer Couplings

PRODUCT DESCRIPTION

- Designed for moderate to higher speed applications
- Construction includes:
 - Two fully machined steel hubs
 - One fully machined steel spool spacer
 - Standard hardware and stainless steel disc packs
- Form-Flex® A-Series designs use non-unitized disc packs
- Form-Flex® G-Series designs use unitized disc packs
- Custom length spacer up to max DBSE
- Balancing and other modifications to suit your special system requirements
- Can be bored for any shaft configuration (see page 34 & 35 for hub design options)



TYPICAL APPLICATIONS

- Pumps
- Centrifugal and Screw Compressors
- Fans and Blowers
- Mixers
- Turbo Compressors

SPECIAL APPLICATIONS

- Test Stands
- Machine Tools / Positioning Systems
- Electrical Insulation



Riddhi Engineering Company

www.couplings-mounts.com
sales@riddhiengineeringco.com
+91 74900 32784

Spacer Coupling AP Series - Form-Flex®

Double Flex Spacer

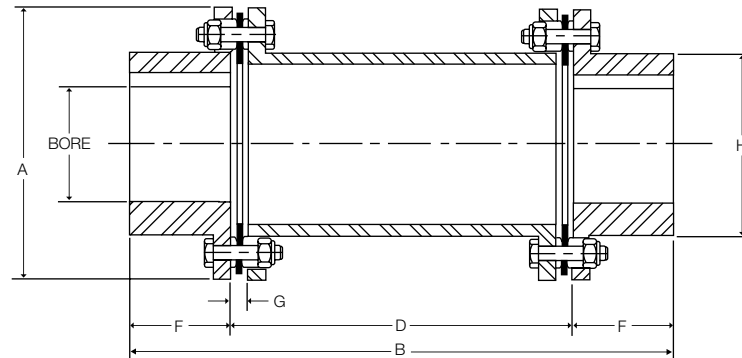

COUPLING CAN BE SUPPLIED TO API610 11TH EDITION

Size	Max Bore				Dimensions (mm)								
	AJ		AZ		A	B		D DBSE		F	G	H	J
	(mm)	(in)	(mm)	(in)		Min	Max	Min	Max				
5	22	0.875	30	1.19	67.3	94.5	176.2	43.7	125.4	25.4	6.1	33.0	13.7
10	33	1.250	43	1.63	81.0	103.1	177.8	52.3	127.0	25.4	6.9	45.7	14.2
15	36	1.375	48	1.75	92.7	118.6	225.7	61.2	168.3	28.7	8.1	50.8	22.4
20	46	1.688	58	2.13	103.6	127.5	235.3	60.5	168.3	33.5	8.6	61.0	20.1
25	53	2.000	68	2.56	125.7	156.5	333.1	74.2	250.8	41.1	11.4	71.1	25.4
30	63	2.380	79	2.88	143.0	192.3	347.9	96.8	252.4	47.8	11.9	83.8	29.0
35	80	2.938	101	3.75	168.4	223.8	446.1	109.5	331.8	57.2	14.0	105.4	24.6

Dimensions are shown for standard AJ hubs unless otherwise specified.

Size	kW/100 RPM	Rated Torque (Nm)	Peak O/L Torque (Nm)	AGMA 7 Max RPM	Weight (kg) (1)		WR ² (kg-cm ²) (1)		Misalignment Capacity	
					at D Min	Add Per cm of D	at D Min	Add Per cm of D	Axial (+/-mm)	Angular (Degrees/Disc Pack)
5	0.36	34	68	8,500	1.05	0.025	5.47	0.058	0.076	1°
10	0.95	90	181	7,500	1.65	0.039	13.11	0.127	1.01	
15	1.87	178	356	6,700	2.47	0.047	25.93	0.219	1.06	
20	2.60	249	497	6,200	3.16	0.057	40.38	0.392	1.39	
25	4.50	429	859	5,500	5.77	0.073	113.5	0.714	1.52	
30	8.21	783	1566	5,000	8.64	0.082	227.4	1.060	1.65	
35	13.4	1281	2562	4,400	12.55	0.113	456.5	2.638	2.16	

1) Weight and WR² values shown are for AJ hubs at max inch bore and spacer length at D Min

STANDARD MATERIALS (CLASS A)

HUBS - CARBON STEEL

SPACER - CARBON STEEL

HARDWARE - ALLOY STEEL

DISC PACK - STAINLESS STEEL

ORDERING

AP SERIES COUPLINGS ARE SOLD AS COMPONENTS

COUPLINGS CONSIST OF:

2 - HUBS - Example (AJ25A x 45 mm)

1 - SPACER SUB-ASSEMBLY - Example for DBSE = 120 mm (AP25A120MM)

MATERIAL / FINISH OPTIONS

CLASS A - Steel hubs and spacer, alloy steel hardware, 300 series stainless steel disc pack

CLASS B - Zinc plated steel hubs, and spacer, alloy steel hardware, 300 series stainless steel disc pack

CLASS C - Zinc plated steel hubs, and spacer, stainless steel hardware, 300 series stainless steel disc pack

CLASS E - 300 series stainless steel hubs and spacer, stainless steel hardware, 300 series stainless steel disc pack

(Only available for sizes 15 thru 35)



Riddhi Engineering Company

www.couplings-mounts.com

sales@riddhiengineeringco.com

+91 74900 32784

Spacer Coupling GP Series - Form-Flex®

Double Flex Spacer

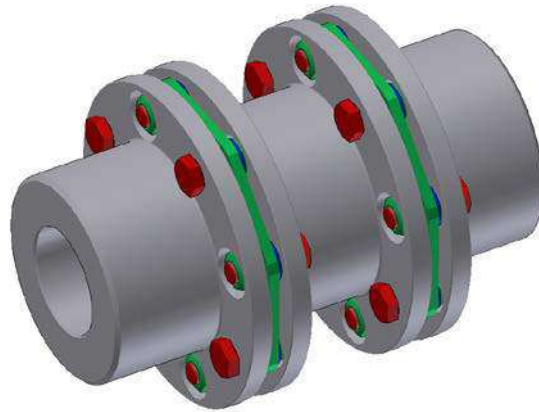

Size	Torque Rating			Max Speed (RPM)		Weight (kg) (1)		WR ² (kg-m ²) (1)		Misalignment Capacity	
	kW / 100 (RPM)	Max Continuous (Nm)	Peak Overload (Nm)	AGMA 8	ABS. Max	at D Min	Add Per cm of D	at D Min	Add Per cm of D	Axial (+/- mm)	Angular (Degrees/ Disc Pack)
311	13.0	1,243	2,486	5,400	13,000	7.36	0.11	0.020	0.00024	0.711	0.5°
321	24.3	2,316	4,632	4,900	12,000	11.70	0.12	0.036	0.00029	0.737	
332	37.9	3,615	7,231	4,400	11,500	18.30	0.17	0.071	0.00049	0.762	
346	54.4	5,197	10,394	4,100	9,000	24.74	0.18	0.126	0.00080	1.27	
380	94.7	9,039	18,077	3,800	7,000	36.05	0.21	0.232	0.00101	2.03	
412	142	13,558	27,116	3,500	6,000	50.03	0.26	0.470	0.00153	2.03	0.33°
419	225	21,467	42,933	3,000	5,000	89.92	0.42	1.071	0.00322	2.54	
424	355	33,894	67,789	2,750	5,000	130.7	0.55	2.378	0.00720	2.54	
444	515	49,147	98,294	2,500	4,000	187.9	0.60	3.976	0.01003	2.79	
456	758	72,308	144,616	2,350	3,500	244.8	0.85	6.408	0.01538	3.05	
483	982	93,775	187,549	2,200	3,500	330.6	0.96	9.848	0.02247	3.30	
511	1420	135,578	271,156	2,050	3,000	444.7	1.21	17.582	0.03575	3.56	
520	2367	225,963	451,926	1,750	2,500	796	1.81	33.65	0.06756	4.57	
525	2959	282,454	564,908	1,700	2,500	960	1.98	54.42	0.08784	5.08	
530	3551	338,945	677,890	1,600	2,500	1151	2.76	71.22	0.13373	5.08	
540	4735	451,926	903,853	1,450	2,000	1741	3.44	163.27	0.25894	6.10	

1) Weight and WR² values shown are for standard hubs at max inch bore and spacer length at D Min

STANDARD MATERIALS

HUBS - CARBON STEEL

SPACER - CARBON STEEL

HARDWARE - ALLOY STEEL

DISC PACK - STAINLESS STEEL

MATERIAL / FINISH OPTIONS

DISC PACK - ALLOY STEEL (For cost reduction, available for sizes 412 to 540)

ZINC ELECTRO PLATING

ZINC PHOSPHATE COATING

ALLOY STEEL HUBS



Riddhi Engineering Company

www.couplings-mounts.com

sales@riddhiengineeringco.com

+91 74900 32784

Spacer Coupling GP Series - Form-Flex®

Double Flex Spacer

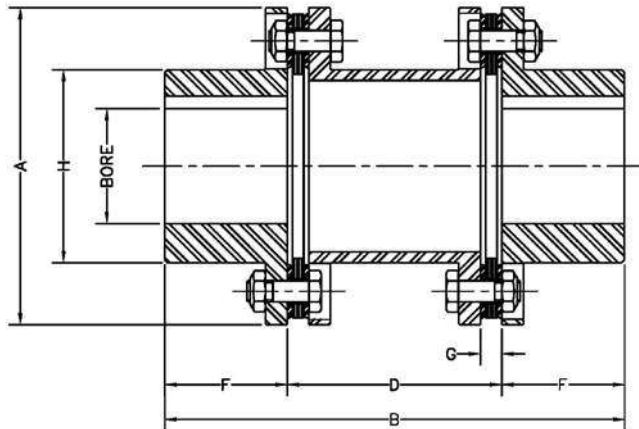

COUPLING CAN BE SUPPLIED TO API610 11TH EDITION

Size	Max Bore						Common Coupling Dimensions (mm)								
	Standard Hub			Oversized/Large Hub			A	B		D DBSE		F	G	H	
	Rect. Key (mm)	Rect. Key (in)	Square Key (in)	Rect. Key (mm)	Rect. Key (in)	Square Key (in)		Min	Max	Min	Max			Std Hub	O/S Hub
311	78	3.063	2.813	86	3.313	3.125	149.4	204.8	450.9	77.8	323.9	63.5	10.2	99.2	109.3
321	83	3.250	3.000	90	3.438	3.250	162.1	257.2	484.2	104.8	331.8	76.2	14.0	108.0	116.1
332	87	3.313	3.188	95	3.688	3.438	182.9	279.4	487.4	127.0	335.0	88.9	15.5	114.3	125.6
346	107	4.000	3.750	117	4.500	4.250	208.3	279.4	639.8	127.0	487.4	95.3	15.6	137.7	151.0
380	105	4.000	3.750	118	4.500	4.250	237.7	381.0	711.2	171.5	501.7	104.8	22.6	143.5	160.0
412	120	4.500	4.500	135	5.125	4.750	279.4	360.4	709.6	144.5	493.7	108.0	18.9	165.4	182.8
419	130	4.875	4.500	150	5.625	5.500	317.5	449.3	760.4	195.3	506.4	127.0	24.9	185.9	205.0
424	190	6.880	6.625				381.0	512.8	823.9	195.3	506.4	158.8	24.9	243.1	
444	200	7.375	7.000				415.9	577.9	866.8	222.3	511.2	177.8	27.7	267.2	
456	220	8.000	8.000				457.2	617.6	892.2	249.3	523.9	184.2	33.5	295.4	
483	234	8.875	8.250				493.7	703.3	958.9	271.5	527.1	215.9	35.3	319.1	
511	280	10.125	10.000				558.8	754.1	992.2	296.9	535.0	228.6	39.6	368.3	
520	297	11.000	10.375				631.8	977.9	1155.7	374.7	552.5	301.6	48.0	408.9	
525	322	12.000	11.000				679.5	1000.1	1165.2	390.5	555.6	304.8	49.5	440.7	
530	338	12.750	11.500				711.2	1063.6	1212.9	415.9	565.2	323.9	54.2	466.1	
540	448	17.000	15.750				850.9	1244.6	1374.8	482.6	612.8	381.0	65.4	574.7	

ORDERING

GP SERIES COUPLINGS ARE SOLD AS COMPLETE ASSEMBLIES
 PLEASE SPECIFY BORE SIZES, DISC PACK MATERIAL AND DBSE.
 A COUPLING WILL BE CONFIGURED TO MEET YOUR SPECIFICATIONS.



Riddhi Engineering Company

www.couplings-mounts.com

sales@riddhiengineeringco.com

+91 74900 32784

Floating Shaft Couplings

PRODUCT DESCRIPTION

- Used for coupling spans that are greater than max catalog length for fully machined spacer designs
- Designed for moderate speed applications
- Construction includes:
 - Two fully machined steel hubs
 - One dynamically balanced welded or composite tube spacer
 - Standard hardware and stainless steel disc packs
- Form-Flex® A-Series designs use non-unitized disc packs
- Form-Flex® G-Series designs use unitized disc packs
- Spacers are configured for any custom length up to D-max shown per operating speed
- Can be bored for any shaft configuration (see page 34 & 35 for hub design options)

TYPICAL APPLICATIONS

- Fans
- Turbo Compressors
- Vertical Pumping
- Cooling Tower
- Printing Press
- Paper Machines

SPECIAL APPLICATIONS

- Mine Ventilation
- Dynamometers
- Test Stands
- Dredging Equipment
- Lift Tables

DESIGN VARIATIONS

- A5/G5 - Welded Steel Tube
- A6/G6 - Welded Steel Tube - Vertical
- A7/G7 - Welded Steel Tube - Semi-Floating Spacer
- A5C/G5C - Composite Tube
- A6C/G6C - Composite Tube - Vertical
- A7C/G7C - Composite Tube - Semi-Floating

Large tube designs are available for speeds greater than catalog limits or for torsional tuning. Consult Altra Couplings engineering for more info.



Riddhi Engineering Company

www.couplings-mounts.com
sales@riddhiengineeringco.com
+91 74900 32784

Floating Shaft Spacer Coupling A5 Series - Form-Flex®

Double Flex Floating Shaft

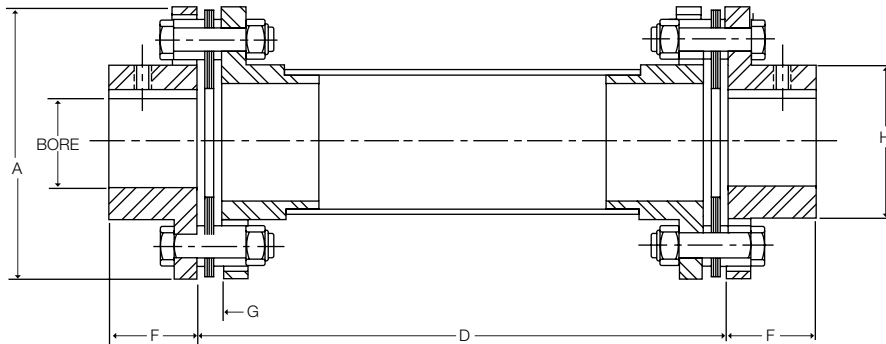

Size	Max Bore				Dimensions (mm)					Max D (mm) for RPM Shown					
	AJ		AZ		A	D Min	F	G	H	1800	1500	1200	900	750	600
	(mm)	(in)	(mm)	(in)											
5	22	0.875	30	1.19	67.3	125.5	25.4	6.1	33.0	1295	1422	1575	1803	1981	2210
10	33	1.250	43	1.63	81.0	127.0	25.4	6.9	45.7	1575	1753	1930	2235	2438	2718
15	36	1.375	48	1.75	92.7	168.4	28.7	8.1	50.8	1626	1803	2007	2311	2515	2819
20	46	1.688	58	2.13	103.6	168.4	33.5	8.6	61.0	1854	2057	2286	2616	2870	3200
25	53	2.000	68	2.56	125.7	251.0	41.1	11.4	71.1	2007	2210	2464	2845	3099	3480
30	63	2.380	79	2.88	143.0	252.5	47.8	11.9	83.8	2159	2388	2591	3048	3353	3734
35	80	2.938	101	3.75	168.4	331.7	57.2	14.0	105.4	2464	2718	3023	3480	3810	4267

Dimensions are shown for standard AJ hubs unless otherwise specified.

Size	kW/100 RPM	Rated Torque (Nm)	Peak O/L Torque (Nm)	Weight (kg) (1)		WR ² (kg-cm ²) (1)		Misalignment Capacity	
				at D min	Add Per cm of D	at D min	Add Per cm of D	Axial (+/-mm)	Angular (Degrees/Disc Pack)
5	0.36	34	68	1.23	0.020	5.65	0.035	0.76	1°
10	0.95	90	181	1.88	0.018	14.13	0.081	1.01	
15	1.87	178	356	2.79	0.018	27.39	0.081	1.06	
20	2.60	249	497	3.95	0.038	44.95	0.253	1.39	
25	4.50	429	859	6.81	0.036	123.1	0.334	1.52	
30	8.21	783	1566	10.35	0.052	248.7	0.645	1.65	
35	13.4	1281	2562	14.55	0.072	499.9	1.521	2.16	

1) Weight and WR² values shown are for AJ hubs at max inch bore and spacer length at D Min

STANDARD MATERIALS (CLASS A)

HUBS - CARBON STEEL

SPACER - CARBON STEEL

HARDWARE - ALLOY STEEL

DISC PACK - STAINLESS STEEL

ORDERING

A5 Series couplings are sold as complete assemblies. Please specify hub types and bore sizes, DBSE (D) dimension, speed for dynamic balancing, and material class. A coupling will be configured to meet your specifications.

MATERIAL / FINISH OPTIONS

CLASS A - Steel hubs and spacer, alloy steel hardware, 300 series stainless steel disc pack

CLASS B - Zinc plated steel hubs, and spacer, alloy steel hardware, 300 series stainless steel disc pack

CLASS C - Zinc plated steel hubs, and spacer, stainless steel hardware, 300 series stainless steel disc pack

CLASS E - 300 series stainless steel hubs and spacer, stainless steel hardware, 300 series stainless steel disc pack

(Only available for sizes 15 thru 35)



Riddhi Engineering Company

www.couplings-mounts.com

sales@riddhiengineeringco.com

+91 74900 32784

Floating Shaft Spacer Coupling G5 Series - Form-Flex®

Double Flex Floating Shaft



Size	Torque Rating			Weight (1) (kg)		WR ² (1) (kg-m ²)		Misalignment Capacity	
	kW / 100 (RPM)	Max Continuous (Nm)	Peak Overload (Nm)	at D Min	Add Per cm of D	at D Min	Add Per cm of D	Axial (+/- mm)	Angular (Degrees/ Disc Pack)
311	13.0	1,243	2,486	0.18	0.07	0.025	0.00015	0.711	0.5°
321	24.3	2,316	4,632	0.20	0.08	0.043	0.00022	0.737	
332	37.9	3,615	7,231	0.21	0.08	0.079	0.00026	0.762	
346	54.4	5,197	10,394	0.50	0.20	0.166	0.00080	1.27	
380	94.7	9,039	18,077	0.53	0.21	0.276	0.00093	2.03	
412	142	13,558	27,116	0.93	0.37	0.577	0.00221	2.03	0.33°
419	225	21,467	42,933	1.00	0.40	1.211	0.00279	2.54	
424	355	33,894	67,789	1.38	0.54	2.767	0.00730	2.54	
444	515	49,147	98,294	1.54	0.60	4.571	0.00997	2.79	
456	758	72,308	144,616	2.22	0.88	7.198	0.01704	3.05	
483	982	93,775	187,549	2.32	0.91	11.112	0.01947	3.30	
511	1420	135,578	271,156	2.32	0.91	18.801	0.01947	3.56	
520	2367	225,963	451,926	CONSULT ALTRA COUPLINGS ENGINEERING				4.57	
525	2959	282,454	564,908					5.08	
530	3551	338,945	677,890					5.08	
540	4735	451,926	903,853					6.10	

1) Weight and WR² values shown are for standard at max inch bore and spacer length at D Min

STANDARD MATERIALS

HUBS - CARBON STEEL

SPACER - CARBON STEEL

HARDWARE - ALLOY STEEL

DISC PACK - STAINLESS STEEL

MATERIAL OPTIONS

DISC PACK - ALLOY STEEL (for cost reduction, only available on sizes 412 to 540)

ZINC ELECTRO PLATING

ZINC PHOSPHATE COATING

ALLOY STEEL HUBS

DESIGN VARIATIONS

- G5 - Welded Steel Tube
- G6 - Welded Steel Tube—Vertical
- G7 - Welded Steel Tube—Semi-Floating Spacer
- G5C - Composite Tube
- G6C - Composite Tube—Vertical
- G7C - Composite Tube— Semi-Floating



Riddhi Engineering Company

www.couplings-mounts.com

sales@riddhiengineeringco.com

+91 74900 32784

Floating Shaft Spacer Coupling G5 Series - Form-Flex®

Double Flex Floating Shaft

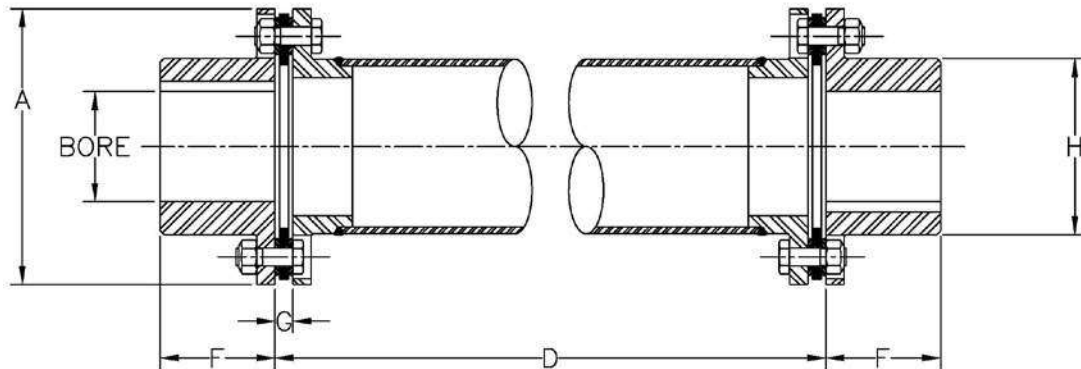

Size	Max Bore						Common Coupling Dimensions (mm)								Max D (mm) for RPM Shown					
	Standard Hub			Oversized/Large Hub			A	D Min	F	G	H		Tube		1800	1500	1200	900	750	600
	Rect. Key (mm)	Rect. Key (in)	Square Key (in)	Rect. Key (mm)	Rect. Key (in)	Square Key (in)					Std Hub	O/S Hub	OD	ID						
311	78	3.063	2.813	86	3.313	3.125	149.4	323.9	63.5	10.2	99.2	109.3	92.2	86.1	2388	2616	2946	3404	3708	4166
321	83	3.250	3.000	90	3.438	3.250	162.1	331.8	76.2	14.0	108.0	116.1	101.6	95.5	2565	2794	3150	3632	3962	4445
332	87	3.313	3.188	95	3.688	3.438	182.9	335.0	88.9	15.5	114.3	125.6	108.0	101.9	2642	2896	3226	3734	4089	4572
346	107	4.000	3.750	117	4.500	4.250	208.3	487.4	95.3	15.6	137.7	151.0	133.4	120.7	2819	3099	3454	3988	4369	4877
380	105	4.000	3.750	118	4.500	4.250	239.3	501.7	104.8	22.6	143.5	160.0	139.7	127.0	2896	3175	3556	4089	4496	5004
412	120	4.500	4.500	135	5.125	4.750	279.4	493.7	108.0	18.9	165.4	182.8	165.1	146.1	3124	3429	3835	4420	4851	5410
419	130	4.875	4.500	150	5.625	5.500	317.5	506.4	127.0	24.9	185.9	205.0	177.8	158.8	3251	3556	3988	4597	5029	5639
424	190	6.880	6.625				381.0	506.4	158.8	24.9	243.1		241.3	222.3	3810	4166	4674	5385	5918	6604
444	200	7.375	7.000				415.9	511.2	177.8	27.7	267.2		266.7	247.7	4013	4394	4928	5690	6223	6960
456	220	8.000	8.000				457.2	523.9	184.2	33.4	295.4		292.1	266.7	4191	4597	5131	5918	6502	7264
483	234	8.875	8.250				493.7	527.1	215.9	35.3	319.1		304.8	279.4	4267	4674	5232	6045	6629	7417
511	280	10.125	10.000				558.8	535.0	228.6	39.5	368.3		304.8	279.4	4267	4674	5232	6045	6629	7417
520	297	11.000	10.375				631.8	552.5	301.6	48.0	408.9									
525	322	12.000	11.000				679.5	555.6	304.8	49.5	440.7									
530	338	12.750	11.500				711.2	565.2	323.9	54.2	466.1									
540	448	17.000	15.750				850.9	612.8	381.0	65.4	574.7									

CONSULT ALTRA COUPLINGS ENGINEERING

ORDERING

G5 SERIES COUPLINGS ARE SOLD AS COMPLETE ASSEMBLIES
 PLEASE SPECIFY BORE SIZES, DISC PACK MATERIAL AND DBSE.
 A COUPLING WILL BE CONFIGURED TO MEET YOUR SPECIFICATIONS.



Riddhi Engineering Company

www.couplings-mounts.com
 sales@riddhiengineeringco.com
 +91 74900 32784

Floating Shaft Spacer Coupling A5C/B5C Composite Series - Form-Flex®

Double Flex Spacer

Form-Flex® flexible couplings may be mated to composite tubes for use as long floating shaft couplings. All types and most sizes of Form-Flex® couplings can be mated to composite tubes. Common combinations are shown below.

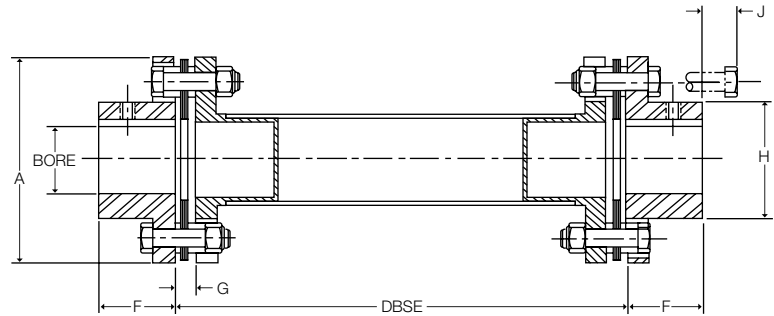

Size	Rated Torque*** (Nm)	kW/ 100 RPM	Coupling Product No.	Maximum DBSE (mm)			Maximum Bore			
				Max	@1800 RPM	@1500 RPM	Std Hub		AZ Hub	
							Square Key (in)	Reduced Key (mm[in])	Square Key (in)	Reduced Key (mm[in])
A5C20	249	3.49	A5C20_2G	2133	1828	2004	1.625	45 [1.75]	2.125	57 [2.188]
			A5C20_2R	2133	2133*	2133*				
A5C25	429	6.03	A5C25_2G	2108	1802	1980	2.00	52 [2.063]	2.500	68 [2.750]
			A5C25_2R	2108	2108*	2108*				
A5C30	783	11	A5C30_3R	3302	2723	2985	2.375	61 [2.438]	2.875	78 [3.063]
			A5C30_3B	3302	3101	3302*				
A5C35	1,281	18	A5C35_4R	3734	3130	3431	2.875	80 [3.125]	3.750	100 [3.75]
			A5C35_4B	3734	3564	3734*				
			A5C35_6R	3862	3799	3862*				
			A5C35_6B	4597	4327	4597*				
			A5C35_6BL	4978	-	4746				
			A5C35_8R	4975	4671	4975*				
			A5C35_8B	4975	4975	4975*				
			A5C35_8BL	5991	-	5459				
A5C40	2,064	29	A5C40_4R	3734	3129	3431	3.250	88 [3.375]	4.000	113 [4.375]
			A5C40_4B	3734	3563	3734*				
B5C58	3,841	54	B5C58_6R	4592	3807	3854	4.000	110 [4.250]	5.000	143 [5.500]
			B5C58_6B	4592	4337	4592*				
			B5C58_6BL	4978	-	4754				
			B5C58_6X	4978	4423	4849				
			B5C58_8R	5004	4682	5004*				
			B5C58_8B	5004	4974	5004*				
			B5C58_8BL	6020	-	5456				
			B5C58_10B**	6020	5414	6020*				
B5C58_12B**	6020	6020*	6020*							

Type	Coupling Product No.	Dimensions (mm) (1)					Misalignment Capacity	
		A	F	G	H	J	Axial (+/-mm)	Angular (Degrees/ Disc Pack)
A5C20	A5C20_2G	103.6	33.5	8.6	61.0	58.4	1.40	1°
	A5C20_2R					58.4		
A5C25	A5C25_2G	125.7	41.1	11.4	71.1	58.4	1.52	1°
	A5C25_2R					58.4		
A5C30	A5C30_3R	143.0	47.8	11.9	83.8	82.6	1.65	1°
	A5C30_3B					82.6		
A5C35	A5C35_4R	168.4	57.2	14.0	105.4	108.0	2.16	1°
	A5C35_4B					108.0		
	A5C35_6R					160.0		
	A5C35_6B					160.0		
	A5C35_6BL					160.0		
	A5C35_8R					211.1		
	A5C35_8B					211.1		
	A5C35_8BL					211.1		
A5C40	A5C40_4R	193.8	63.5	15.2	118.1	108.0	2.54	1°
	A5C40_4B					108.0		
B5C58	B5C58_6R	228.1	69.9	14.2	147.6	160.0	3.00	0.7°
	B5C58_6B					160.0		
	B5C58_6BL					160.0		
	B5C58_6X					211.1		
	B5C58_6XL					211.1		
	B5C58_8R					261.9		
	B5C58_8B					261.9		
	B5C58_8BL					261.9		
	B5C58_10B**					261.9		
	B5C58_12B**					312.6		

* Length is restricted by available mandrels for winding composite tubes. Consult factory for longer lengths.

** Tube diameter is larger than coupling "A" diameter. Consult factory for coupling drawing.

*** Peak Overload Torque Rating is 1.5 times Rated Torque

1) Dimensions are shown with standard hubs



Riddhi Engineering Company

www.couplings-mounts.com
sales@riddhiengineeringco.com
+91 74900 32784

Floating Shaft Spacer Coupling A5C/B5C Composite Series - Form-Flex®

QUICK SELECTION GUIDE FOR COOLING TOWER APPLICATIONS

1800 RPM				Coupling Model	1500 RPM			
DBSE		Max Power			Max Power		Max DBSE	
mm	in	Kw	HP		Kw	HP	mm	in
1828	72	23	31	A5C20_2G	20	26	2004	79
1802	71	40	54	A5C25_2G	34	45	1980	78
2133*	84*	23	31	A5C20_2R	20	26	2133*	84*
2108*	83*	40	54	A5C25_2R	34	45	2108*	83*
2723	107	74	99	A5C30_3R	62	82	2985	117
3101	122	74	99	A5C30_3B	62	82	3302*	130*
3130	123	121	161	A5C35_4R	100	134	3431	135
3129	123	194	260	A5C40_4R	162	217	3431	135
3564	140	121	161	A5C35_4B	100	134	3734*	147*
3563	140	194	260	A5C40_4B	162	217	3734*	147*
3799	149	121	161	A5C35_6R	100	134	3862*	152*
3807	149	362	485	B5C58_6R	302	404	3854	151
4327	170	121	161	A5C35_6B	100	134	4597*	181*
4337	170	362	485	B5C58_6B	302	404	4592*	181*
-	-	121	161	A5C35_6BL	100	134	4746	187
-	-	362	485	B5C58_6BL	302	404	4754	187
4423	174	362	485	B5C58_6X	302	404	4849	190
4671	184	121	161	A5C35_8R	100	134	4975*	196*
4682	184	362	485	B5C58_8R	302	404	5004*	197*
4975*	196*	121	161	A5C35_8B	100	134	4975	196
4974	196	362	485	B5C58_8B	302	404	5004*	197*
-	-	121	161	A5C35_8BL	100	134	5459	215
-	-	362	485	B5C58_8BL	302	404	5456	215
5414	213	362	485	B5C58_10B	302	404	6020*	237*
6020*	237*	362	485	B5C58_12B	302	404	6020*	237*

All sections use a 2.0 service factor

ORDER CODE

A5C35_6B

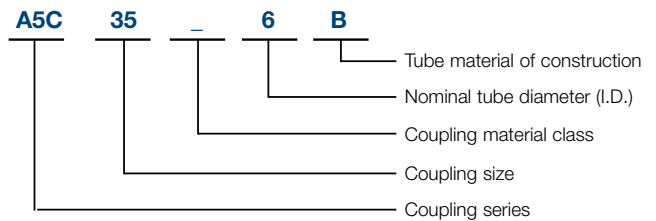

COMPOSITE TUBE CONSTRUCTION

Model Code	Tube Material of Construction
G	GLASS
R	CARBON/GLASS HYBRID
B	STANDARD CARBON
X,Z	HIGH MODULUS CARBON

Material Class	Material Used		
	Hub	Hardware	Spacer Flanges
A	STEEL	STEEL	COMPOSITE OR STEEL
B	STEEL, ZINC PLATE	STEEL	COMPOSITE OR ZINC PLATED STEEL
C		304SS	
E	304SS	304SS	COMPOSITE OR 304SS

Metal spacer flanges used if composite is not available.

* Length is restricted by available mandrels for winding composite tubes. Consult factory for longer lengths.

** Tube diameter is larger than coupling "A" diameter. Consult factory for coupling drawing.



Riddhi Engineering Company

www.couplings-mounts.com

sales@riddhiengineeringco.com

+91 74900 32784

Close Coupled Couplings

PRODUCT DESCRIPTION

- Used for close shaft spacing where traditional spacer couplings cannot be used
- Designed for moderate speed applications
- Construction includes:
 - Two fully machined steel hubs
 - One flat bar or machined block style spacer
 - Standard hardware and stainless steel disc packs
- Form-Flex® AA, AX and AY designs use non-unitized disc packs

Spacers are configured for minimal shaft separation. Shorter shaft separation is possible by allowing the shafts to extend through the disc packs into the center of the coupling. The shaft diameter must be less than the flex pack I.D. listed in the dimensional table.



TYPICAL APPLICATIONS

- Machine Tools
- Ball Screws
- Pumps
- Printing Machines

SPECIAL APPLICATIONS

- Elastomeric Coupling Replacement
- Cranes
- Gear Coupling Replacement



Riddhi Engineering Company

www.couplings-mounts.com
sales@riddhiengineeringco.com
+91 74900 32784

Close Coupled Coupling AX Series - Form-Flex®

General Use - Double Flex Short Spacer

The AX series close coupling is made up of two hubs, a steel spacer block, two stainless steel disc packs and AX hardware. A special bolting arrangement supports the spacer between the flex discs. The AX is an economical design that is well suited to many general purpose applications. The AX accommodates close shaft separations when it is installed with the shafts extending through the flex discs into the center of the coupling. The shaft diameter must be less than the disc pack I.D. listed in the dimensional table.

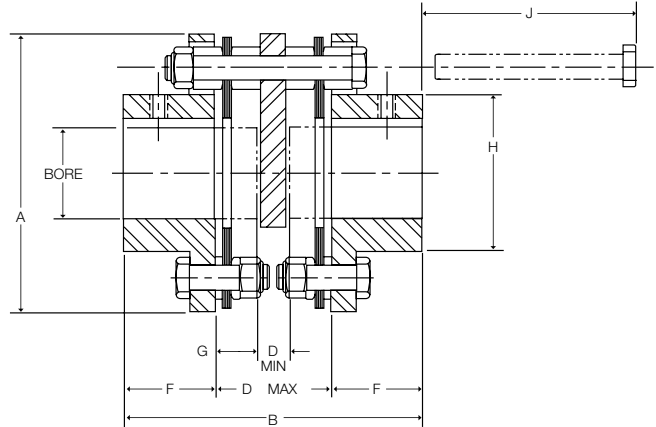

Size	Max Bore				Dimensions (mm)*									
	AJ		AZ		A	B	DBSE		F	G	H	J	DISC PACK I.D.**	
	(mm)	(in)	(mm)	(in)			D** Min	D Max						
5	22	0.875	30	1.19	67.3	84.8	9.7	34.0	25.4	12.2	33.0	42.7	25.4	
10	33	1.250	43	1.63	81.0	86.4	11.2	35.6	25.4	12.2	33.0	45.5	29.7	
15	36	1.375	48	1.75	92.7	96.5	16.0	39.1	28.7	11.2	50.8	47.0	32.5	
20	46	1.688	58	2.13	103.6	107.2	16.0	40.1	33.5	12.2	61.0	42.2	41.9	
25	53	2.000	68	2.56	125.7	136.1	19.1	53.8	41.1	17.5	71.1	60.7	45.2	
30	63	2.380	79	2.88	143.0	160.0	25.4	64.5	47.8	19.6	83.8	80.8	51.1	
35	80	2.938	101	3.75	168.4	182.1	28.7	67.8	57.2	19.6	105.4	71.4	68.8	

* Dimension shown are for AJ hubs unless otherwise specified.

** Shaft O.D. must be less than Disc Pack I.D. in order to extend shafts into the coupling to meet D Min dimensions.

Size	kW/100 RPM	Rated Torque (Nm)	Peak O/L Torque (Nm)	Max RPM	Weight (kg) (1)	WR ² (kg-cm ²) (1)	Misalignment Capacity	
							Axial (+/-mm)	Angular (Degrees/Disc Pack)
5	0.36	34	51	3,600	0.74	3.69	.076	1°
10	0.95	90	136	3,500	1.13	8.49	1.01	
15	1.87	178	267	3,450	1.75	16.97	1.06	
20	2.60	249	373	3,350	2.32	26.81	1.39	
25	4.50	429	644	3,200	4.15	76.38	1.52	
30	8.21	783	1174	3,000	6.27	151.3	1.65	
35	13.4	1281	1922	2,800	9.59	316.1	2.16	

1) Weight and WR² values shown are for AJ hubs at max inch bore.

STANDARD MATERIALS (CLASS A)

HUBS - CARBON STEEL

SPACER - CARBON STEEL

HARDWARE - ALLOY STEEL

DISC PACKS - STAINLESS STEEL

ORDERING

AX SERIES COUPLINGS ARE SOLD AS COMPONENTS

COUPLINGS CONSIST OF:

2 - HUBS - Example (AJ25A x 35 MM)

1 - SPACER SUB-ASSEMBLY - Example (AX25SAA)

STANDARD MATERIALS (CLASS A)

CLASS A - Mild steel hubs and spacer, alloy steel hardware, 300 series stainless steel disc packs

CLASS B - Zinc plated steel hubs, and spacer, alloy steel hardware, 300 series stainless steel disc packs



Riddhi Engineering Company

www.couplings-mounts.com

sales@riddhiengineeringco.com

+91 74900 32784

Close Coupled Coupling AA Series - Form-Flex®

General Use with Shorter Bolt Removal - Double Flex

The AA series close coupling is made up of two hubs, a cast iron block type spacer and two sets of standard hardware. Stainless steel disc packs are standard. The AA accommodates close shaft separations when it is installed with the shafts extending through the disc pack into the center of the coupling. The shaft diameter must be less than the disc pack I.D. listed in the dimensional table. This coupling is recommended when the bolt removal length (J) makes the AX coupling impractical.

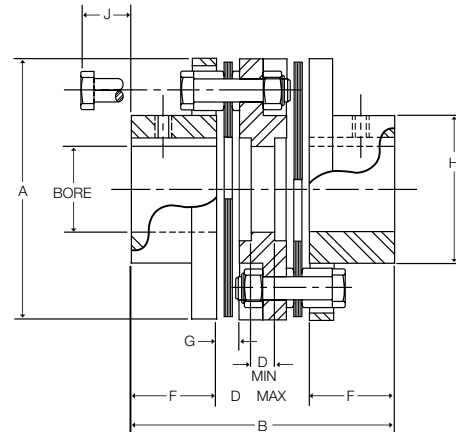

Size	Max Bore				Dimensions (mm)*								
	AJ		AZ		A	B	DBSE		F	G	H	J	Disc Pack I.D.**
	(mm)	(in)	(mm)	(in)			D** Min	D Max					
5	22	0.875	30	1.19	67.3	82.0	6.4	31.2	25.4	6.1	33.0	13.7	25.4
10	33	1.250	43	1.63	81.0	94.7	6.4	43.9	25.4	6.9	45.7	14.2	29.7
15	36	1.375	48	1.75	92.7	97.0	7.9	39.6	28.7	8.1	50.8	22.4	32.5
20	46	1.688	58	2.13	103.6	111.3	10.4	44.2	33.5	8.6	61.0	20.1	41.9
25	53	2.000	68	2.56	125.7	133.6	10.4	51.3	41.1	11.4	71.1	25.4	45.2
30	63	2.380	79	2.88	143.0	158.5	14.2	63.0	47.8	11.9	83.8	29.0	51.1
35	80	2.938	101	3.75	168.4	175.5	16.8	61.2	57.2	14.0	105.4	24.6	68.8

* Dimension shown are for AJ hubs unless otherwise specified.

** Shaft O.D. must be less than Disc Pack I.D. in order to extend shafts into the coupling to meet D Min dimensions.

Size	kW/100 RPM	Rated Torque (Nm)	Peak O/L Torque (Nm)	Max RPM	Weight (kg) (1)	WR ² (kg-cm ²) (1)	Misalignment Capacity	
							Axial (+/-mm)	Angular (Degrees/Disc Pack)
5	0.36	34	51	3,600	0.80	4.10	.076	1°
10	0.95	90	136	3,500	1.26	9.80	1.01	
15	1.87	178	267	3,450	1.93	19.49	1.06	
20	2.60	249	373	3,350	2.49	29.85	1.39	
25	4.50	429	644	3,200	4.46	86.04	1.52	
30	8.21	783	1174	3,000	6.82	172.7	1.65	
35	13.4	1281	1922	2,800	10.18	354.1	2.16	

1) Weight and WR² values shown are for AJ hubs at max inch bore.

STANDARD MATERIALS (CLASS A)

HUBS - CARBON STEEL

SPACER - CARBON STEEL

HARDWARE - ALLOY STEEL

DISC PACK - STAINLESS STEEL

ORDERING

AA SERIES COUPLINGS ARE SOLD AS COMPONENTS

COUPLINGS CONSIST OF:

2 - HUBS - Example (AJ25A x 35 MM)

1 - SPACER SUB-ASSEMBLY - Example (AA25SAA)

MATERIAL / FINISH OPTIONS

CLASS A - Steel hubs and spacer, alloy steel hardware, 300 series stainless steel disc pack

CLASS B - Zinc plated steel hubs, and spacer, alloy steel hardware, 300 series stainless steel disc pack

CLASS C - Zinc plated steel hubs, and spacer, stainless steel hardware, 300 series stainless steel disc pack



Ridhi Engineering Company

www.couplings-mounts.com

sales@ridhiengineeringco.com

+91 74900 32784

Close Coupled Coupling AY Series - Form-Flex®

Positioning Applications - Double Flex Short Spacer

The AY series is specifically designed for positioning applications where a servo or stepper drive is C flange mounted and connects to a ball screw. The AY accommodates the small amounts of angular and parallel misalignment with an absolute minimum size package, zero backlash and high torsional stiffness. The AY is made up of two hubs, a steel spacer block, two stainless steel disc packs and AY hardware. The coupling must be installed as an assembled unit. The spacer is not service removable.

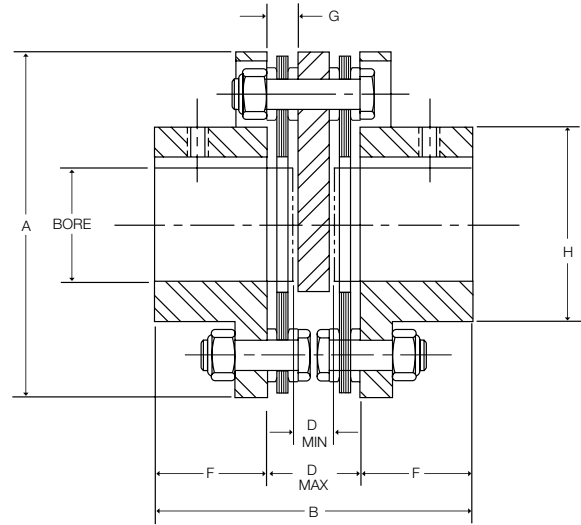

Size	Max Bore				Dimensions (mm)*							
	AJ		AZ		A	B	DBSE		F	G	H	Disc Pack I.D.**
	(mm)	(in)	(mm)	(in)			D** Min	D Max				
5	22	0.875	30	1.19	67.3	72.4	12.4	21.6	25.4	6.1	33.0	25.4
10	33	1.250	43	1.63	81.0	73.9	12.7	23.1	25.4	6.9	45.7	29.7
15	36	1.375	48	1.75	92.7	84.6	14.2	27.2	28.7	8.1	50.8	32.5
20	46	1.688	58	2.13	103.6	95.5	14.2	28.4	33.5	8.6	61.0	41.9
25	53	2.000	68	2.56	125.7	121.2	22.1	38.9	41.1	11.4	71.1	45.2

* Dimension shown are for AJ hubs unless otherwise specified.

** Shaft O.D. must be less than Disc Pack I.D. in order to extend shafts into the coupling to meet D Min dimensions.

Size	kW/100 RPM	Rated Torque (Nm)	Peak O/L Torque (Nm)	AGMA 7 Max RPM	Weight (kg) (1)	WR ² (kg-cm ²) (1)	Misalignment Capacity	
							Axial (+/-mm)	Angular (Degrees/Disc Pack)
5	0.36	34	68	8,500	0.75	3.63	0.76	1°
10	0.95	90	181	7,500	1.22	9.01	1.01	
15	1.87	178	356	6,700	1.92	18.76	1.06	
20	2.60	249	497	6,200	2.50	29.03	1.39	
25	4.50	429	859	5,500	4.45	80.77	1.52	

1) Weight and WR2 values shown are for AJ hubs at max inch bore.

STANDARD MATERIALS (CLASS A)

HUBS - CARBON STEEL

SPACER - CARBON STEEL

HARDWARE - ALLOY STEEL

DISC PACK - STAINLESS STEEL

ORDERING

AY SERIES COUPLINGS ARE SOLD AS COMPONENTS

COUPLINGS CONSIST OF:

2 - HUBS - Example (AJ25A x 35 MM)

1 - SPACER SUB-ASSEMBLY - Example (AY25SAA)

MATERIAL / FINISH OPTIONS

CLASS A - Mild steel hubs and spacer, alloy steel hardware, 300 series stainless steel disc pack

CLASS B - Zinc plated steel hubs, and spacer, alloy steel hardware, 300 series stainless steel disc pack



Riddhi Engineering Company

www.couplings-mounts.com

sales@riddhiengineeringco.com

+91 74900 32784

Single Flex Couplings

PRODUCT DESCRIPTION

- Single Flex Couplings accommodate angular and axial misalignment only
- Construction includes:
 - Two fully machined steel hubs
 - Standard hardware and stainless steel disc packs
- Form-Flex® A-Series designs use non-unitized disc packs
- Form-Flex® G-Series designs use unitized disc packs
- Not intended for elastomeric coupling replacement
- Hubs can be single plane balanced for higher speed applications
- Can be bored for any shaft configuration (see page 34 for hub design options)

TYPICAL APPLICATIONS

- Should only be used in three bearing system
- Used in pairs for floating shaft arrangement
- Can be used in pairs to support other components
 - Clutches
 - Brakes
 - Sheaves
- Mixers
- Single coupling can be used to support a component when a self-aligning bearing is used

SPECIAL APPLICATIONS

- Torque Monitoring Equipment

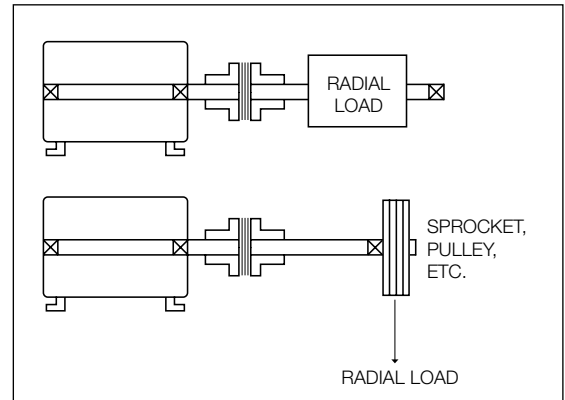

Riddhi Engineering Company

www.couplings-mounts.com

sales@riddhiengineeringco.com

+91 74900 32784

Single Flex Coupling AR Series - Form-Flex®

Single Flex Short Spacing

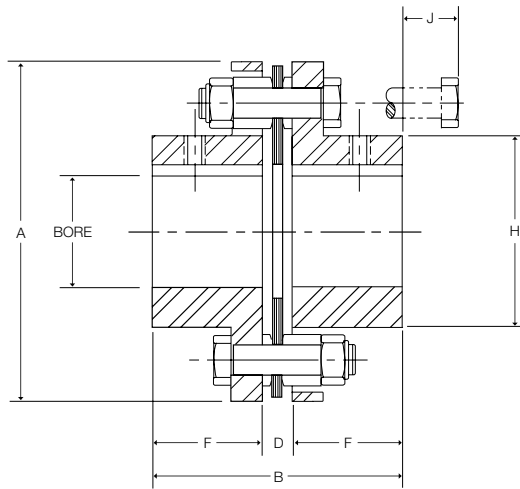

Size	Max Bore				Dimensions (mm)*					
	AJ		AZ		A	B	D DBSE	F	H	J
	(mm)	(in)	(mm)	(in)						
5	22	0.875	30	1.19	67.3	56.9	6.1	25.4	33.0	13.7
10	33	1.250	43	1.63	81.0	57.7	6.9	25.4	45.7	15.0
15	36	1.375	48	1.75	92.7	65.5	8.1	28.7	50.8	22.4
20	46	1.688	58	2.13	103.6	75.7	8.6	33.5	61.0	20.1
25	53	2.000	68	2.56	125.7	93.7	11.4	41.1	71.1	25.4
30	63	2.380	79	2.88	143.0	107.4	11.9	47.8	83.8	29.0
35	80	2.938	101	3.75	168.4	128.3	14.0	57.2	105.4	24.6

* Dimension shown are for AJ hubs unless otherwise specified.

Size	kW/100 RPM	Rated Torque (Nm)	Peak O/L Torque (Nm)	AGMA 7 Max RPM	Max Radial Load (kg)	Weight (1) (kg)	WR ² (1) (kg-cm ²)	Misalignment Capacity	
								Axial (+/-mm)	Angular (Degrees/Disc Pack)
5	0.36	34	68	8,500	15	0.56	2.81	0.381	1°
10	0.95	90	181	7,500	25	0.89	6.88	0.508	
15	1.87	178	356	6,700	57	1.35	13.52	0.533	
20	2.60	249	497	6,200	83	1.85	21.89	0.686	
25	4.50	429	859	5,500	125	3.19	59.70	0.762	
30	8.21	783	1566	5,000	182	4.91	121.4	0.813	
35	13.4	1281	2562	4,400	273	7.82	258.4	1.067	

1) Weight and WR² values shown are for AJ hubs at max inch bore.

STANDARD MATERIALS (CLASS A)

HUBS - CARBON STEEL

SPACER - CARBON STEEL

HARDWARE - ALLOY STEEL

DISC PACKS - STAINLESS STEEL

ORDERING

AR SERIES COUPLINGS ARE SOLD AS COMPONENTS

COUPLINGS CONSIST OF:

2 - HUBS - Example (AJ25A x 35 MM)

1 - REPAIR KIT - Example (A25RKA)

MATERIAL / FINISH OPTIONS

CLASS A - Steel hubs, alloy steel hardware, 300 series stainless steel disc packs

CLASS B - Zinc plated steel hubs and spacer, alloy steel hardware, 300 series stainless steel disc pack

CLASS C - Zinc plated steel hubs, stainless steel hardware, 300 series stainless steel disc packs

CLASS E - 300 series stainless steel hubs, stainless steel hardware, 300 series stainless steel disc packs

Single Flex Coupling GR Series - Form-Flex®

Single Flex Short Spacing



Size	Torque Rating			Max Speed (RPM)		Max Radial Load (kg)	Weight (kg) (1)	WR ² (kg-m ²) (1)	Misalignment Capacity	
	kW/100 (RPM)	Max Continuous (Nm)	Peak Overload (Nm)	AGMA 8	ABS. Max				Axial (+/- mm)	Angular (Degrees/ Disc Pack)
311	13.0	1,243	2,486	8,000	13,000	164	5.0	0.012	0.356	0.5°
321	24.3	2,316	4,632	7,400	12,000	364	8.1	0.023	0.368	
332	37.9	3,615	7,231	6,600	11,500	591	11.9	0.042	0.381	
346	54.4	5,197	10,394	6,100	9,000	591	17.3	0.079	0.635	
380	94.7	9,039	18,077	5,500	7,000	1,091	24.1	0.137	1.02	
412	142	13,558	27,116	5,200	6,000	1,091	32.9	0.274	1.02	0.33°
419	225	21,467	42,933	4,600	5,000	1,909	58.8	0.612	1.27	
424	355	33,894	67,789	4,200	5,000	1,909	89.0	1.445	1.27	
444	515	49,147	98,294	3,800	4,000	2,409	132.5	2.465	1.40	
456	758	72,308	144,616	3,600	3,500	3,045	165.4	3.870	1.52	
483	982	93,775	187,549	3,300	3,500	3,727	232.7	6.099	1.65	
511	1420	135,578	271,156	3,100	3,000	4,455	307.8	10.850	1.78	
520	2367	225,963	451,926	2,800	2,500	7,136	549	21.026	2.29	
525	2959	282,454	564,908	2,700	2,500	8,136	669	33.34	2.54	
530	3551	338,945	677,890	2,500	2,500	9,545	796	43.49	2.54	
540	4735	451,926	903,853	2,300	2,000	10,455	1210	101.53	3.05	

1) Weight and WR² values shown are for standard hubs at max inch bore.

STANDARD MATERIALS

HUBS - CARBON STEEL

SPACER - CARBON STEEL

HARDWARE - ALLOY STEEL

DISC PACKS - STAINLESS STEEL

MATERIAL / FINISH OPTIONS

DISC PACKS - ALLOY STEEL (For cost reduction, available for sizes 412 to 540)

ZINC ELECTRO PLATING

ZINC PHOSPHATE COATING

ALLOY STEEL HUBS



Riddhi Engineering Company

www.couplings-mounts.com

sales@riddhiengineeringco.com

+91 74900 32784

Single Flex Coupling GR Series - Form-Flex®

Single Flex Short Spacing

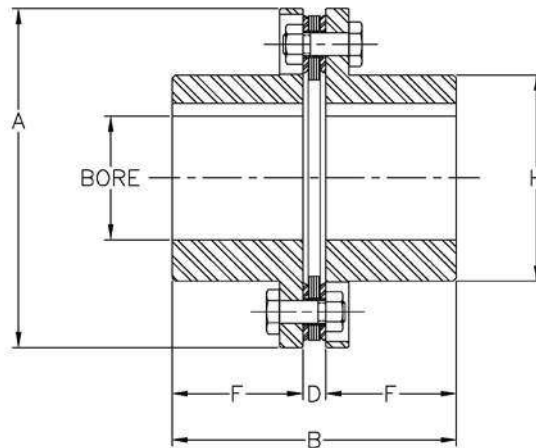

Size	Max Bore						Common Coupling Dimensions (mm)						
	Standard Hub			Oversized/Large Hub			A	B	D DBSE	F	G	H	
	Rect. Key (mm)	Rect. Key (in)	Square Key (in)	Rect. Key (mm)	Rect. Key (in)	Square Key (in)						Std Hub	O/S Hub
311	78	3.063	2.813	86	3.313	3.125	149.4	137.2	10.2	63.5	10.2	99.2	109.3
321	83	3.250	3.000	90	3.438	3.250	162.1	166.3	13.9	76.2	14.0	108.0	116.1
332	87	3.313	3.188	95	3.688	3.438	182.9	168.0	15.6	88.9	15.5	114.3	125.6
346	107	4.000	3.750	117	4.500	4.250	208.3	168.0	15.6	95.3	15.6	137.7	151.0
380	105	4.000	3.750	118	4.500	4.250	239.3	232.2	22.6	104.8	22.6	143.5	160.0
412	120	4.500	4.500	135	5.125	4.750	279.4	234.8	18.9	108.0	18.9	165.4	182.8
419	130	4.875	4.500	150	5.625	5.500	317.5	278.9	24.9	127.0	24.9	185.9	205.0
424	190	6.880	6.625				381.0	342.4	24.9	158.8	24.9	243.1	
444	200	7.375	7.000				415.9	383.3	27.7	177.8	27.7	267.2	
456	220	8.000	8.000				457.2	401.7	33.4	184.2	33.4	295.4	
483	234	8.875	8.250				493.7	467.1	35.3	215.9	35.3	319.1	
511	280	10.125	10.000				558.8	496.7	39.5	228.6	39.5	368.3	
520	297	11.000	10.375				631.8	651.3	48.0	301.6	48.0	408.9	
525	322	12.000	11.000				679.5	659.1	49.5	304.8	49.5	440.7	
530	338	12.750	11.500				711.2	701.9	54.2	323.9	54.2	466.1	
540	448	17.000	15.750				850.9	827.4	65.4	381.0	65.4	574.7	

ORDERING

GR SERIES COUPLINGS ARE SOLD AS COMPONENTS

COUPLINGS CONSIST OF:

2 - HUBS - Example (GH346 x 55 MM)

1 - REPAIR KIT - Example (G346SF)



Riddhi Engineering Company

www.couplings-mounts.com

sales@riddhiengineeringco.com

+91 74900 32784

Heavy Duty Spacer Coupling

PRODUCT FEATURES

- Designed for low to medium speed equipment
- Standard designs for applications requiring shaft-to-shaft or shaft to flywheel connection.
- Construction
 - Fully machined steel hubs are standard
 - Ductile Iron or Class 30 Grey Iron spacer/spyder
 - Ductile Iron or Class 30 Grey Iron flywheel adapter
 - Alloy steel hardware and High Carbon steel disc packs
- Form-Flex® HSH/FSH Series designs use non-unitized disc packs
- Form-Flex® GCH/GCF Series designs use unitized disc packs
- Industry standard length spacer
- Can be bored for any shaft configuration (see page 34 & 35 for hub design options)
- Special flange mountings are also available to bolt custom flanges on any equipment.



TYPICAL APPLICATIONS

- Reciprocating Compressors
- Metal Shredders
- Rock Crushers
- Engine Driven Equipment
- Mixer

SPECIAL APPLICATIONS

- Can be modified for API671 with exceptions
- Added inertia to torsionally tune system
- Altered stiffness for torsional tuning
- Custom designs for demanding applications

SPECIAL APPLICATIONS

Example: Coupling shown was specially designed for a high torque, low speed (10000HP @ 290RPM) application to torsionally tune the system. This is a 10 bolt disc pack design and the coupling is rated for 10,000,000 lb-in with an OD measuring 44.50". Flange mounted on both ends with a custom adapter hub on the motor's keyless shaft.



Riddhi Engineering Company

www.couplings-mounts.com

sales@riddhiengineeringco.com

+91 74900 32784

Heavy Duty Spacer Coupling GCH Series - Form-Flex®

Double Flex Spacer

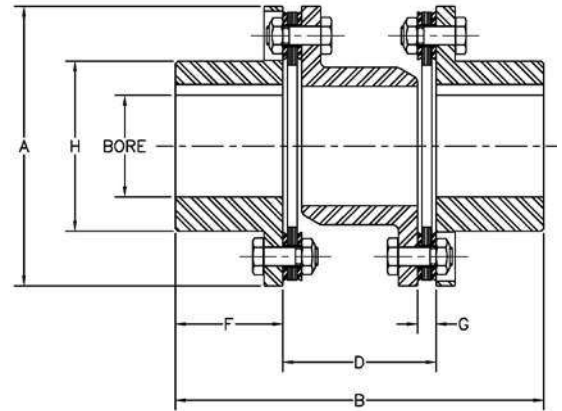

Size	Spacer	Max Bore		Dimensions (mm)					
		(mm)	(in)	A	B	D	F	G	H
340	31	100	3.75	212.9	251.2	105.2	73.2	14.5	138.2
	35				265.7	119.6			
412	42	120	4.50	279.4	357.4	141.5	108.0	19.1	165.4
	45				370.1	154.2			
	50				398.5	182.6			
424	55	190	6.88	381	506.7	189.2	158.8	24.9	243.1
	60				532.1	214.6			
456	70	220	8.00	457.2	612.9	244.6	184.2	33.5	295.4
	75				640.1	271.8			
511	80	280	10.00	558.8	746.5	289.3	228.6	39.6	368.3
	85				771.9	314.7			
	92				810.0	352.8			

Size	Spacer	Rated Torque		Peak Overload (Nm)	Max RPM	Weight (1) (kg)	WR ² (1) (kg-m ²)	Misalignment Capacity	
		kW/100 RPM	(Nm)					Axial (+/- mm)	Angular (Degrees/Disc Pack)
340	31	48	4,519	6,779	3,400	19.5	0.101	1.52	0.33°
	35					20.0	0.102		
412	42	142	13,558	20,337	2,500	48.0	0.401	2.03	
	45					49.0	0.405		
	50					50.8	0.414		
424	55	283	27,116	40,673	1,800	126	2.09	2.54	
	60					129	2.12		
456	70	663	63,270	94,905	1,500	239	5.71	3.05	
	75					244	5.79		
511	80	1,303	124,280	186,420	1,200	437	15.91	3.56	
	85					444	16.10		
	92					503	18.85		

Note: Couplings available for torque capacity up to 1129815 Nm. Contact Altra Couplings engineering with application details for coupling selection.

STANDARD MATERIALS

HUBS - CARBON STEEL
 SPACER - DUCTILE IRON
 HARDWARE - ALLOY STEEL
 DISC PACKS - HIGH CARBON STEEL

MATERIAL / FINISH OPTIONS

DISC PACKS - STAINLESS STEEL
 ZINC PHOSPHATE COATING
 ALLOY STEEL HUBS
 STEEL SPACER

NOTES:

- 1) Weight and WR² are calculated with hubs at maximum inch bore size.
- 2) Consult factory for torsional stiffness and alternating torque limits.

ORDERING

GCH SERIES COUPLINGS ARE SOLD AS COMPLETE ASSEMBLIES

- 1) Specify coupling size and spacer option
 Example: GCH424-60 85 MM X 120 MM
- 2) Specify hub bore size and tolerance, keyway size or keyless, special hub length, etc. Please specify for each hub.



Riddhi Engineering Company
 www.couplings-mounts.com
 sales@riddhiengineeringco.com
 +91 74900 32784

Heavy Duty Spacer Coupling GCF Series - Form-Flex®

Double Flex Spacer

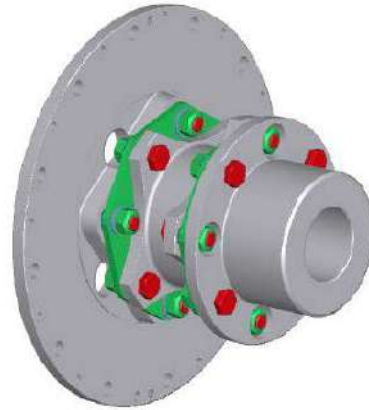
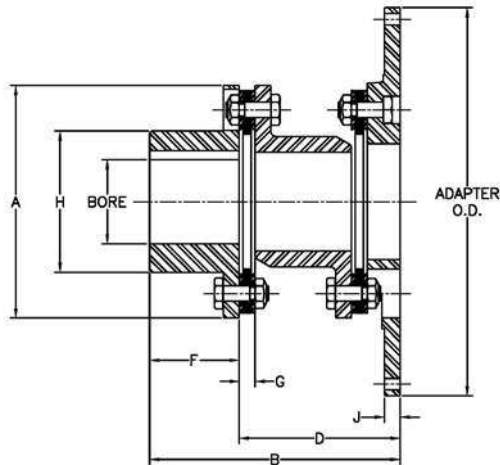

Size	Spacer	Max Bore		Dimensions (mm)							Size	Adapter O.D. (mm [in]) / Standard Bolt Pattern						
		(mm)	(in)	A	B	D	F	G	H	J		314.33 [12.375]	352.43 [13.875]	466.73 [18.375]	517.53 [20.375]	571.50 [22.500]	673.10 [26.500]	733.43 [28.875]
340	31	100	3.75	212.9	208.0	134.9	73.2	14.5	138.2	12.7	340	Order	SAE	SAE	Order	SAE		
	35				222.5	149.4					412			SAE	Order	SAE	SAE/HD	SAE/HD
412	42	120	4.50	279.4	289.3	181.4	108.0	19.1	165.4	14.5	424			SAE/HD	Order	SAE/HD	SAE/HD	SAE/HD
	45				302.0	194.1					456			SAE/HD		SAE/HD	SAE/HD	SAE/HD
	50				330.5	222.5					511					SAE/HD	SAE/HD	SAE/HD
424	55	190	6.88	381	410.0	251.2	158.8	24.9	243.1	25.4	SAE Bolting							
	60				435.4	276.6					BC	295.28	333.38	438.15	488.95	542.93	641.35	692.15
456	70	220	8.00	457.2	500.1	316.0	184.2	33.5	295.4	28.7	Hole Qty	8	8	8	8	6	12	12
	75				527.3	343.2					Hole Dia	10.4	10.4	13.5	13.5	16.5	16.5	19.8
511	80	280	10.00	558.8	603.5	374.9	228.6	39.6	368.3	35.1	HD Bolting							
	85				628.9	400.3					BC	292.10	317.50	425.45	469.90	520.70	622.30	682.63
	92				667.0	438.4					Hole Qty	8	8	8	8	8	12	12
											Hole Dia	13.5	16.5	19.8	23.1	26.2	26.2	26.2
											Speed Limit by Adapter O.D. (2b)							
											RPM	3,400	3,400	2,900	2,600	2,400	2,000	1,800

Size	Spacer	Rated Torque		Peak Overload (Nm)	Max RPM (2a)	Weight (1) (kg)	WR ² (1) (kg-m ²)	Misalignment Capacity	
		kW/100 RPM	(Nm)					Axial (+/- mm)	Angular (Degrees/Disc Pack)
340	31	48	4,519	6,779	3,400	20.9	0.166	1.52	0.33°
	35					21.4	0.167		
412	42	142	13,558	20,337	2,500	57.7	0.956	2.03	
	45					58.5	0.960		
	50					60.0	0.969		
424	55	283	27,116	40,673	1,800	118	2.44	2.54	
	60					122	2.44		
456	70	663	63,270	94,905	1,500	223	6.60	3.05	
	75					228	6.68		
511	80	1,303	124,280	186,420	1,200	395	17.23	3.56	
	85					401	17.41		
	92					460	20.16		

- 1) Weight and WR² calculated with hub at maximum inch bore size and minimum available adapter size.
- 2) a) Max RPM shown for smallest available adapter size, do not exceed this speed for any given coupling size.
b) Verify that adapter speed limit is adequate for application speed, do not exceed coupling MAX RPM (See note 2a).
- 3) Flywheel mounting hardware is not supplied with coupling.
- 4) Consult factory for torsional stiffness and alternating torque limits.

ORDERING

- 1) Specify coupling size and spacer option
Example: GCF424-60
- 2) Specify adapter size code. Specify bolting pattern for items noted as drilled per order.
Example: GCF424-60-26 or GCF424-60-22HD
- 3) Specify hub bore size and tolerance, keyway size or keyless, special hub length, etc.

STANDARD MATERIALS

HUB - CARBON STEEL
 SPACER - DUCTILE IRON
 FLYWHEEL ADAPTER - DUTILE IRON
 HARDWARE - ALLOY STEEL
 DISC PACKS - HIGH CARBON STEEL



Riddhi Engineering Company

www.couplings-mounts.com
 sales@riddhiengineeringco.com
 +91 74900 32784

Heavy Duty Spacer Coupling HSH Series - Form-Flex®

Double Flex Spacer

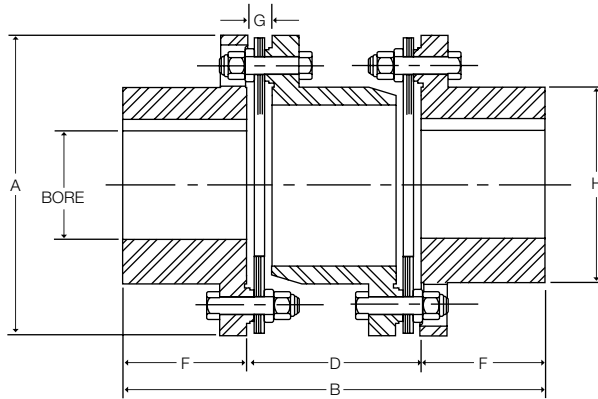

Size	Dimensions (mm)									
	Max Bore				A (2)	B	D DBSE	F	G	H
	Iron		Steel							
(mm)	(in)	(mm)	(in)							
22	-	-	79	2.75	149.2	203.7	76.7	63.5	10.9	98.3
26	-	-	92	3.25	174.8	235.0	88.9	73.2	14.0	114.3
31	82	3.12	113	4.13	206.2	276.1	104.6	85.6	15.7	139.7
35	97	3.62	125	4.50	231.6	306.3	116.1	95.3	16.8	155.4
37	100	3.75	130	4.63	255.5	333.2	130.6	101.6	20.6	165.1
42	114	4.25	142	5.00	279.4	353.8	137.9	108.0	20.6	177.8
45	120	4.50	150	5.50	301.5	374.7	146.1	114.3	22.1	188.7
50	-	-	170	6.13	327.7	427.0	173.0	127.0	26.9	212.6
55	-	-	193	6.88	381.0	474.5	195.1	139.7	31.8	241.3
60	-	-	212	7.50	406.4	531.6	214.1	158.8	34.0	266.7
70	-	-	233	8.50	469.9	599.9	242.8	177.8	38.1	298.5
75	-	-	261	9.00	508.0	635.0	266.7	184.2	38.9	330.2
80	-	-	275	9.12	558.8	682.5	288.8	196.9	39.6	349.3
85	-	-	290	10.38	603.3	726.9	307.8	209.6	41.1	368.3
92	-	-	320	11.00	654.1	787.4	330.5	228.6	44.5	403.1
92HT	-	-	307	10.50	654.1	787.4	330.5	228.6	44.5	403.1

STANDARD MATERIALS

HUBS - CARBON STEEL
 SPACER - GREY OR DUCTILE IRON
 HARDWARE - ALLOY STEEL
 DISC PACKS - HIGH CARBON STEEL

MATERIAL / FINISH OPTIONS

DISC PACKS - STAINLESS STEEL
 ZINC PHOSPHATE COATING
 ALLOY STEEL HUBS
 CAST IRON HUBS
 (Sizes 31-45)

Size	kW/ 100 RPM	Rated Torque (Nm)	Peak O/L Torque (Nm)	Max RPM	Weight (kg) (l)	WR ² (kg-m ²) (l)	Misalignment Capacity	
							Axial (+/- mm)	Angular (Degrees/ Disc pack)
22	11.2	1,073	1,610	3,800	9.0	0.022	0.91	0.33°
26	18.9	1,808	2,712	3,300	13.1	0.044	1.12	
31	28.4	2,712	4,067	2,800	23.4	0.114	1.32	
35	52.1	4,971	7,457	2,600	34.9	0.216	1.42	
37	71.0	6,779	10,168	2,500	42.0	0.319	1.57	
42	86.5	8,248	12,371	2,400	56.8	0.500	1.70	
45	117	11,185	16,778	2,250	70.0	0.735	1.83	
50	152	14,462	21,692	2,000	99.1	1.34	2.08	
55	224	21,354	32,030	1,800	131	2.17	2.34	
60	309	29,488	44,232	1,600	183	3.83	2.59	
70	491	46,887	70,331	1,400	284	7.55	2.92	
75	631	60,219	90,329	1,300	358	11.09	3.18	
80	811	77,392	116,089	1,200	468	17.18	3.45	
85	982	93,662	140,493	1,100	559	23.12	3.56	
92	1232	117,501	176,251	1,000	741	37.75	3.96	
92HT	1657	158,174	237,261	1,000	764	40.09	3.96	

- 1) Weight and WR² are calculated with steel hubs at maximum inch bore size.
- 2) Consult factory for torsional stiffness and alternating torque limits.

ORDERING

HSH SERIES COUPLINGS ARE SOLD AS COMPLETE ASSEMBLIES (Components and repair kits are available for repairs)

- 1) Specify coupling
- 2) Specify hub bore size and tolerance, keyway size or specify for each hub.
- 3) Specify disc pack material



Riddhi Engineering Company

www.couplings-mounts.com
 sales@riddhiengineeringco.com
 +91 74900 32784

Heavy Duty Spacer Coupling FSH Series - Form-Flex®

Double Flex Spacer

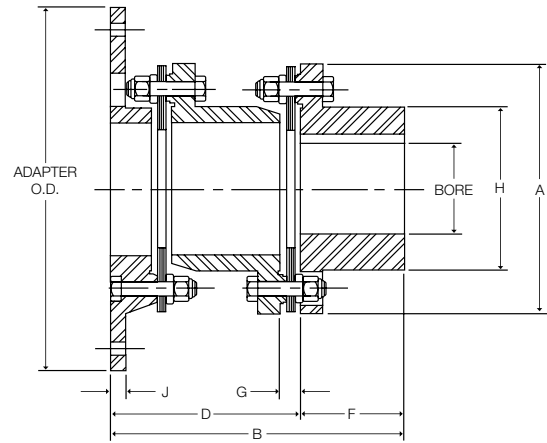

Adapter O.D. / Standard Bolt Pattern						
314.33 [12.375]	352.43 [13.875]	466.73 [18.375]	517.53 [20.375]	571.50 [22.500]	673.10 [26.500]	733.43 [28.875]
12	14	18	20	22	26	28

SAE Bolting							
BC	295.275	333.375	438.15	488.95	542.925	641.35	692.15
Hole Qty	8	8	8	8	6	12	12
Hole Dia	10.414	10.414	13.462	13.462	16.51	16.51	19.812
HD Bolting							
BC	292.1	317.5	425.45	469.9	520.7	622.3	682.625
Hole Qty	8	8	8	8	8	12	12
Hole Dia	13.462	16.51	19.812	23.114	26.162	26.162	26.162

STANDARD MATERIALS

HUBS - CARBON STEEL
 SPACER - DUCTILE IRON OR CAST IRON
 FLYWHEEL ADAPTER - DUCTILE IRON OR CAST IRON
 HARDWARE - ALLOY STEEL
 DISC PACKS - HIGH CARBON STEEL

Size	Max Bore				Dimensions (mm)							Available Adapter Sizes							
	Iron		Steel		A	B	D DBSE	F	G	H	J	X = Stock Size				0 = MTO			
	(mm)	(in)	(mm)	(in)								10	12	14	18	20	22	26	28
31	82	3.12	113	4.13	206.2	220.5	134.9	85.6	15.7	139.7	12.7	O	O	X	X	O	O		
35	97	3.62	125	4.50	231.6	244.3	149.1	95.3	16.8	155.4	12.7	O	O	X	X	O	O		
37	100	3.75	130	4.63	255.5	269.7	168.1	101.6	20.6	165.1	14.2			O	O	O	O		
42	114	4.25	142	5.00	279.4	288.8	180.8	108.0	20.6	177.8	16.0			O	X	O	X	X	O
45	120	4.50	150	5.50	301.5	304.8	190.5	114.3	22.1	188.7	17.5			O	X	O	X	X	O
50	-	-	170	6.13	327.7	349.3	222.3	127.0	26.9	212.6	19.1				X	O	X	X	X
55	-	-	193	6.88	381.0	388.9	249.2	139.7	31.8	241.3	22.4				X	O	X	X	X
60	-	-	212	7.50	406.4	434.8	276.1	158.8	34.0	266.7	25.4				X	O	X	X	X
70	-	-	233	8.50	469.9	493.5	315.7	177.8	38.1	298.5	25.4					X	X	X	X
75	-	-	261	9.00	508.0	527.1	342.9	184.2	38.9	330.2	28.7					O	O	X	X
80	-	-	275	9.12	558.8	571.5	374.7	196.9	39.6	349.3	31.8						O	X	X
85	-	-	290	10.38	603.3	609.6	400.1	209.6	41.1	368.3	31.8							O	X
92	-	-	320	11.00	654.1	666.8	438.7	228.6	44.5	403.1	35.1								X
92HT	-	-	307	10.50	654.1	666.8	438.4	228.6	44.5	403.1	35.1								X

Size	kW/ 100 RPM	Rated Torque (Nm)	Peak O/L Torque (Nm)	Max RPM (2)	Weight (kg) (1)	WR ² (kg-m ²) (1)	Misalignment Capacity	
							Axial (+/- mm)	Angular (Degrees/ Disc Pack)
31	28.4	2,712	4,067	2,800	18.6	0.117	1.32	0.33°
35	52.1	4,971	7,457	2,600	26.8	0.188	1.42	
37	71.0	6,779	10,168	2,500	37.2	0.375	1.57	
42	86.5	8,248	12,371	2,400	48.5	0.518	1.70	
45	117	11,185	16,778	2,250	57.6	0.694	1.83	
50	152	14,462	21,692	2,000	85.7	1.56	2.08	
55	224	21,354	32,030	1,800	109.3	2.22	2.34	
60	309	29,488	44,232	1,600	147.4	3.45	2.59	
70	491	46,887	70,331	1,400	237.2	7.32	2.92	
75	631	60,219	90,329	1,300	306.2	10.24	3.18	
80	811	77,392	116,089	1,200	411	17.09	3.45	
85	982	93,662	140,493	1,100	480.8	23.24	3.56	
92	1232	117,501	176,251	1,000	636	35.12	3.96	
92HT	1657	158,174	237,261	1,000	659	37.75	3.96	

- 1) Weight and WR² calculated with steel hubs at maximum inch bore size and minimum available adapter size.
- 2) a) Max RPM shown for smallest available adapter size, do not exceed this speed for any given coupling size.
 b) Verify that adapter speed limit is adequate for application speed, do not exceed coupling MAX RPM (See note 2a).
- 3) Flywheel mounting hardware is not supplied with coupling.
- 4) Consult factory for torsional stiffness and alternating torque limits.

ORDERING

FSH SERIES COUPLINGS ARE SOLD AS COMPLETE ASSEMBLIES (Components and repair kits are for repairs)

- 1) Specify coupling size and adapter size
- 2) Specify hub bore size and tolerance, keyway keyless, special hub length, etc.
- 3) Specify disc pack material



Riddhi Engineering Company

www.couplings-mounts.com
 sales@riddhiengineeringco.com
 +91 74900 32784



Coupling Repair Parts and Kits

Notes:

- 1) Single Repair Kits include 1 disc pack and all bolts, nuts and washers for use with 1 disc pack
- 2) Single hardware Kits include all bolts, nuts and washers for use with 1 disc pack
- 3) Double Repair Kits include 2 disc packs and all hardware for one coupling
- 4) Double hardware kits include all bolt, nuts and washers for one coupling

Form-Flex® (A Series)

Kit Type	Repair				Hardware				Disc Pack	Rough Bore Hub					
	Single				Double					AJ (Std)			AZ (O/S)		
SGL/DBL									All	All	All	All	All	All	All
Used On	AA, AP, AR, A5, A6, A7									AX	AY				
Mat'l Class	A,B	C,E	A,B	C,E	A,B	A,B	A,B	A,B	All	A	B,C	E	A	B,C	E
5	A05RKA	***	A05HKA	***	AX05RKA	AX05HKA	AY05RKA	AY05HKA	A005-4101	AJ05RBA	AJ05RBB	***	AZ05RBA	AZ05RBB	***
10	A10RKA	***	A10HKA	***	AX10RKA	AX10HKA	AY10RKA	AY10HKA	A010-4101	AJ10RBA	AJ10RBB	***	AZ10RBA	AZ10RBB	***
15	A15RKA	A15RKE	A15HKA	A15HKE	AX15RKA	AX15HKA	AY15RKA	AY15HKA	A015-4101	AJ15RBA	AJ15RBB	AJ15RBE	AZ15RBA	AZ15RBB	AZ15RBE
20	A20RKA	A20RKE	A20HKA	A20HKE	AX20RKA	AX20HKA	AY20RKA	AY20HKA	A020-4101	AJ20RBA	AJ20RBB	AJ20RBE	AZ20RBA	AZ20RBB	AZ20RBE
25	A25RKA	A25RKE	A25HKA	A25HKE	AX25RKA	AX25HKA	AY25RKA	AY25HKA	A025-4101	AJ25RBA	AJ25RBB	AJ25RBE	AZ25RBA	AZ25RBB	AZ25RBE
30	A30RKA	A30RKE	A30HKA	A30HKE	AX30RKA	AX30HKA	***	***	A030-4101	AJ30RBA	AJ30RBB	AJ30RBE	AZ30RBA	AZ30RBB	AZ30RBE
35	A35RKA	A35RKE	A35HKA	A35HKE	AX35RKA	AX35HKA	***	***	A035-4101	AJ35RBA	AJ35RBB	AJ35RBE	AZ35RBA	AZ35RBB	AZ35RBE

Form-Flex® (A5C/B5C Series)

Kit Type	Repair				Hardware				Disc Pack
	Single				Double				
SGL/DBL									All
Used On	A5C, B5C								
Mat'l Class	A,B	C,E	A,B	C,E	A,B	C,E	A,B	C,E	All
15	A5C15RKA	A5C15RKE	A5C15HKA	A5C15HKE	A5C15RKA-DF	A5C15RKE-DF	A5C15HKA-DF	A5C15HKE-DF	A015-4101
20	A5C20RKA	A5C20RKE	A5C20HKA	A5C20HKE	A5C20RKA-DF	A5C20RKE-DF	A5C20HKA-DF	A5C20HKE-DF	A020-4101
25	A5C25RKA	A5C25RKE	A5C25HKA	A5C25HKE	A5C25RKA-DF	A5C25RKE-DF	A5C25HKA-DF	A5C25HKE-DF	A025-4101
30	A5C30RKA	A5C30RKE	A5C30HKA	A5C30HKE	A5C30RKA-DF	A5C30RKE-DF	A5C30HKA-DF	A5C30HKE-DF	A030-4101
35	A5C35RKA	A5C35RKE	A5C35HKA	A5C35HKE	A5C35RKA-DF	A5C35RKE-DF	A5C35HKA-DF	A5C35HKE-DF	A035-4101
58	B5C58RKA	B5C58RKE	B5C58HKA	B5C58HKE	B5C58RKA-DF	B5C58RKE-DF	B5C58HKA-DF	B5C58HKE-DF	B058-4101

Form-Flex® (G Series)

Kit Type	Repair Kits				Hardware Kit	Disc Pack	Rough Bore Hub		
	Double		Single				Std	Oversize	
Used On	SS Disc Pack	CS Disc Pack	SS Disc Pack	CS Disc Pack	Single (1)	SS	CS		
Mat'l Class									
311	G311-DF-SS	-	G311-SF-SS	-	G311-HK	G311-5-SS	-	G311-3ST	G311-3LST
321	G321-DF-SS	-	G321-SF-SS	-	G321-HK	G321-5-SS	-	G321-3ST	G321-3LST
332	G332-DF-SS	-	G332-SF-SS	-	G332-HK	G332-5-SS	-	G332-3ST	G332-3LST
346	G346-DF-SS	-	G346-SF-SS	-	G346-HK	G346-5-SS	-	G346-3ST	G346-3LST
380	G380-DF-SS	-	G380-SF-SS	-	G380-HK	G380-5-SS	-	G380-3ST	G380-3LST
412	G412-DF-SS	G412-DF	G412-SF-SS	G412-SF	G412-HK	G412-5-SS	G412-5	G412-3ST	G412-3LST
419	G419-DF-SS	G419-DF	G419-SF-SS	G419-SF	G419-HK	G419-5-SS	G419-5	G419-3ST	G419-3LST
424	G424-DF-SS	G424-DF	G424-SF-SS	G424-SF	G424-HK	G424-5-SS	G424-5	G424-3ST	-
444	G444-DF-SS	G444-DF	G444-SF-SS	G444-SF	G444-HK	G444-5-SS	G444-5	G444-3ST	-
456	G456-DF-SS	G456-DF	G456-SF-SS	G456-SF	G456-HK	G456-5-SS	G456-5	G456-3ST	-
483	G483-DF-SS	G483-DF	G483-SF-SS	G483-SF	G483-HK	G483-5-SS	G483-5	G483-3ST	-
511	G511-DF-SS	G511-DF	G511-SF-SS	G511-SF	G511-HK	G511-5-SS	G511-5	G511-3ST	-
520	G520-DF-SS	G520-DF	G520-SF-SS	G520-SF	G520-HK	G520-5-SS	G520-5	G520-3ST	-
525	G525-DF-SS	G525-DF	G525-SF-SS	G525-SF	G525-HK	G525-5-SS	G525-5	G525-3ST	-
530	G530-DF-SS	G530-DF	G530-SF-SS	G530-SF	G530-HK	G530-5-SS	G530-5	G530-3ST	-
540	G540-DF-SS	G540-DF	G540-SF-SS	G540-SF	G540-HK	G540-5-SS	G540-5	G540-3ST	-

Form-Flex® (HSH/FSH Series)

Kit Type	Repair Kits				Hardware Kit	Disc Pack		Rough Bore Hub		
	Double		Single (1)			Single (2)	SS	CS	STL	Cast Iron
	SS Disc Pack	CS Disc Pack	SS Disc Pack	CS Disc Pack						
22	D22-DF-SS	D22-DF	D22-SF-SS	D22-SF	D22-BNW	D22-5-SS	D22-5	D22-3ST	-	
26	D26-DF-SS	D26-DF	D26-SF-SS	D26-SF	D26-BNW	D26-5-SS	D26-5	D26-3ST	-	
31	D31-DF-SS	D31-DF	D31-SF-SS	D31-SF	D31-BNW	D31-5-SS	D31-5	D31-3ST	D31-3	
35	D35-DF-SS	D35-DF	D35-SF-SS	D35-SF	D35-BNW	D35-5-SS	D35-5	D35-3ST	D35-3	
37	D37-DF-SS	D37-DF	D37-SF-SS	D37-SF	D37-BNW	D37-5-SS	D37-5	D37-3ST	D37-3	
42	D42-DF-SS	D42-DF	D42-SF-SS	D42-SF	D42-BNW	D42-5-SS	D42-5	D42-3ST	D42-3	
45	D45-DF-SS	D45-DF	D45-SF-SS	D45-SF	D45-BNW	D45-5-SS	D45-5	D45-3ST	D45-3	
50	D50-DF-SS	D50-DF	D50-SF-SS	D50-SF	D50-BNW	D50-5-SS	D50-5	D50-3ST	-	
55	D55-DF-SS	D55-DF	D55-SF-SS	D55-SF	D55-BNW	D55-5-SS	D55-5	D55-3ST	-	
60	D60-DF-SS	D60-DF	D60-SF-SS	D60-SF	D60-BNW	D60-5-SS	D60-5	D60-3ST	-	
70	D70-DF-SS	D70-DF	D70-SF-SS	D70-SF	D70-BNW	D70-5-SS	D70-5	D70-3ST	-	
75	D75-DF-SS	D75-DF	D75-SF-SS	D75-SF	D75-BNW	D75-5-SS	D75-5	D75-3ST	-	
80	D80-DF-SS	D80-DF	D80-SF-SS	D80-SF	D80-BNW	D80-5-SS	D80-5	D80-3ST	-	
85	D85-DF-SS	D85-DF	D85-SF-SS	D85-SF	D85-BNW	D85-5-SS	D85-5	D85-3ST	-	
92	D92-DF-SS	D92-DF	D92-SF-SS	D92-SF	D92-BNW	D92-5-SS	D92-5	D92-3ST	-	
92HT	D92HT-DF-SS	D92HT-DF	D92HT-SF-SS	D92HT-SF	D92HT-BNW	D92-5-SS	D92-5	D92HT-3ST	-	

Form-Flex® (GCH/GCF Series)

Kit Type	Repair Kits				Hardware Kit	Disc Pack		Rough Bore Hub	
	Double		Single (1)			Single (2)	SS	CS	STL
	SS Disc Pack	CS Disc Pack	SS Disc Pack	CS Disc Pack					
340	G340-DF-SS	G340-DF	G340-SF-SS	G340-SF	G340-BN	G340-5-SS	G340-5	G340-3ST	
412	G412-DF-SS	G412-DF	G412-SF-SS	G412-SF	G412-BN	G412-5-SS	G412-5	G412-3ST	
424	G424-DF-SS	G424-DF	G424-SF-SS	G424-SF	G424-BN	G424-5-SS	G424-5	G424-3ST	
456	G456-DF-SS	G456-DF	G456-SF-SS	G456-SF	G456-BN	G456-5-SS	G456-5	G456-3ST	
511	G511-DF-SS	G511-DF	G511-SF-SS	G511-SF	G511-BN	G511-5-SS	G511-5	G511-3ST	

Form-Flex® A-Series Hub Options

TO ORDER A COMPLETE COUPLING, ORDER TWO HUBS OF ANY TYPE AND A COUPLING (SPACER) SUB ASSEMBLY FOR THE REQUIRED COUPLING TYPE. ALL DIMENSIONS SHOWN IN INCHES.

AJ STANDARD HUBS - PROVIDED WITH STRAIGHT BORE AND KEYWAY - SOLID HUBS AVAILABLE FROM STOCK

Size	Max Bore		A	B	F	H	J	Std Set Screw Size
	(mm)	(in)						
5	22	0.875	67.3	6.4	25.4	33.0	9.7	#10-24 UNC
10	33	1.250	81.0	7.6	25.4	45.7	9.7	1/4-20 UNC
15	36	1.375	92.7	8.9	28.7	50.8	10.4	1/4-20 UNC
20	46	1.688	103.6	8.9	33.5	61.0	12.7	1/4-20 UNC
25	53	2.000	125.7	11.4	41.1	71.1	16.0	5/16-18 UNC
30	63	2.380	143.0	14.0	47.8	83.8	17.5	5/16-18 UNC
35	80	2.938	168.4	14.0	57.2	105.4	22.4	1/2-13 UNC

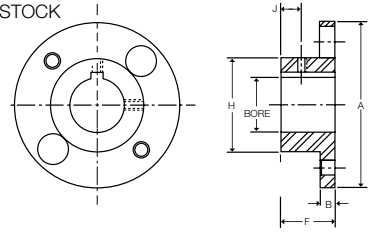

AZ OVERSIZE BORE HUBS - PROVIDED WITH STRAIGHT BORE AND KEYWAY

Size	Max Bore		A	B	F	H	J	Std Set Screw Size
	(mm)	(in)						
5	30	1.188	67.3	6.4	25.4	47.8	9.7	#10-24 UNC
10	43	1.625	81.0	7.6	25.4	60.2	9.7	1/4-20 UNC
15	48	1.750	92.7	8.9	28.7	68.3	10.4	1/4-20 UNC
20	58	2.125	103.6	8.9	33.5	79.5	12.7	1/4-20 UNC
25	68	2.563	125.7	11.4	41.1	95.3	16.0	5/16-18 UNC
30	79	2.875	143.0	14.0	47.8	108.0	17.5	5/16-18 UNC
35	101	3.750	168.4	14.0	57.2	133.4	22.4	1/2-13 UNC

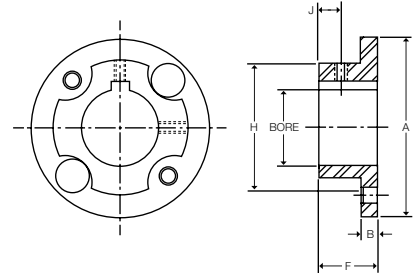

QD BORED HUBS - MATERIAL CLASS A OR B ONLY

Size	Bush Size	Bush TQ. (Nm)	Max Bore		B	C	F	H	Bolt Size
			(mm)	(in)					
15	JA	113	28	1.250	29.7	25.4	14.2	50.8	#10-24 UNC
20	JA	113	28	1.250	29.7	25.4	14.2	61.0	#10-24 UNC
25	SH	395	35	1.688	38.1	31.8	19.1	71.1	1/4-20 UNC
30	SD	565	42	2.000	52.3	46.0	31.8	83.8	1/4-20 UNC
35	SK	791	55	2.625	55.6	47.5	31.8	105.4	5/16-18 UNC
40	SF	1243	65	2.938	60.5	52.3	34.8	118.1	3/8-16 UNC

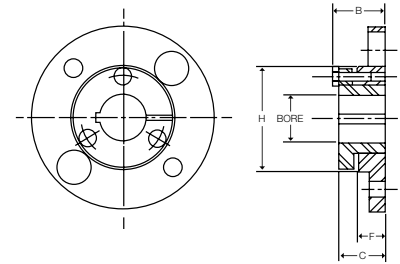

HUBS FOR TAPER LOCK BUSHINGS - AVAILABLE MTO ONLY

Size	Regular Mount				Reverse Mount					
	Bush Size	Bush TQ. (Nm)	Max Bore		F (mm)	Bush Size	Bush TQ. (Nm)	Max Bore		F (mm)
			(mm)	(in)				(mm)	(in)	
15	N/A	-	-	-	-	1108	147	25	1.12	22.1
20	1108	147	25	1.12	22.1	1215	401	32	1.25	38.1
25	1215	401	32	1.25	38.1	1310	435	35	1.37	25.4
30	1310	435	35	1.37	25.4	1615	486	42	1.62	38.1
35	2012	808	48	2.00	31.8	2517	1311	65	2.50	44.5
40	2525	1277	65	2.50	63.5	2525	1277	65	2.50	63.5

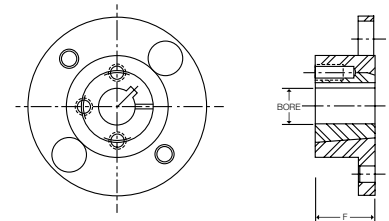

AC/AD CLAMPING HUBS - AC HUBS PROVIDED WITHOUT KEYWAY - AD HUBS PROVIDED WITH KEYWAY - MATERIAL CLASS A OR B ONLY

Size	Max Bore				A	F	G	H	Clamp Screw Size
	AC		AD						
	(mm)	(in)	(mm)	(in)					
5	25	1.00	20	0.87	67.3	28.7	12.7	52.3	1/4-20 UNC
10	25	1.00	20	0.87	81.0	30.0	12.7	52.3	1/4-20 UNC
	38	1.50	30	1.25		34.5	17.5	69.9	5/16-18 UNC
15	25	1.00	20	0.87	92.7	32.3	12.7	52.3	1/4-20 UNC
	44	1.75	24	1.37		37.1	17.5	76.2	5/16-18 UNC
20	33	1.31	24	1.00	103.6	33.5	14.0	60.5	1/4-20 UNC
	53	2.13	42	1.62		38.6	19.1	88.9	3/8-16 UNC
25	53	2.13	42	1.62	125.7	41.1	16.3	88.9	5/16-18 UNC
	63	2.50	50	1.87		47.2	22.4	101.6	3/8-16 UNC

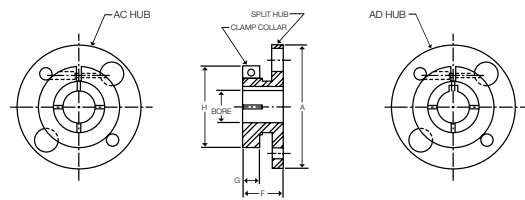

AL LOCK ELEMENT HUBS - THESE HUBS USE RINGFEDER TAPERED LOCKING ELEMENTS - MATERIAL CLASS A OR B ONLY

Size	Hub Type	Bore Size				B	F	G	Screw Size
		Min		Max					
		(mm)	(in)	(mm)	(in)				
5	AJ	6	0.24	13	0.51	25.4	33.5	8.1	#10-32 UNF
	AZ	14	0.55	19	0.75	25.4	36.1	10.7	1/4-28 UNF
10	AJ	12	0.47	18	0.71	25.4	36.1	10.7	1/4-28 UNF
	AZ	19	0.75	30	1.18	25.4	36.1	10.7	1/4-28 UNF
15	AJ	12	0.47	22	0.87	28.7	39.4	10.7	1/4-28 UNF
	AZ	24	0.94	35	1.38	28.7	39.4	10.7	1/4-28 UNF
20	AJ	22	0.87	30	1.18	33.5	45.2	10.7	1/4-28 UNF
	AZ	32	1.26	42	1.65	33.5	46.5	13.0	5/16-24 UNF
25	AJ	22	0.87	32	1.26	41.4	52.1	10.7	1/4-28 UNF
	AZ	35	1.38	50	1.97	41.4	56.6	15.2	3/8-24 UNF

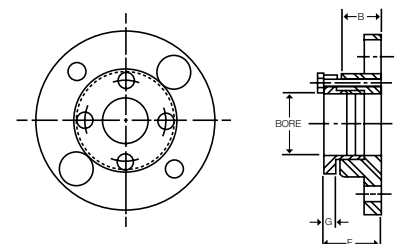

NOTE: AC and AL Hubs do not carry full torque capacity. Please consult engineering.

CLAMP HUB

PROVIDED WITH STRAIGHT BORE AND KEYWAY

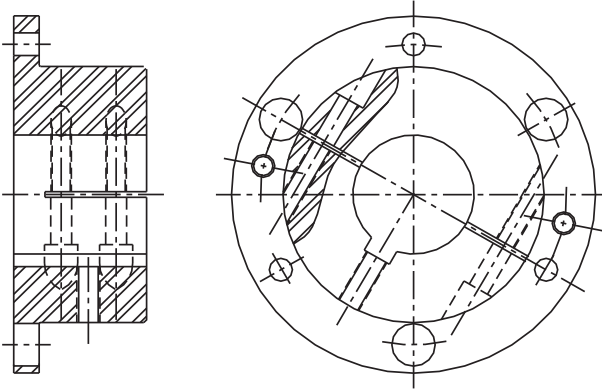

EXTERNAL LOCKING ELEMENT

USED WITH KEYLESS SHAFTS

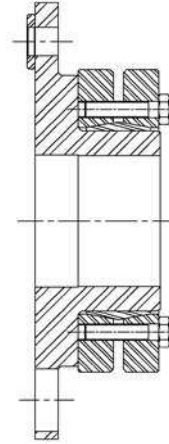

INTERNAL LOCKING ELEMENT

USED WITH KEYLESS SHAFTS

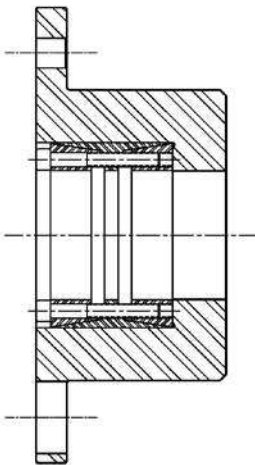

TAPER BORE WITH HYDRAULIC REMOVAL

USED WITH KEYLESS TAPERED SHAFTS

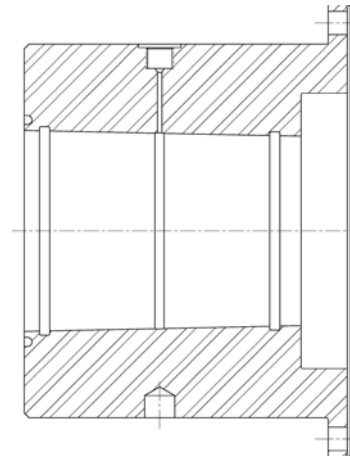

SPECIAL FLANGE ADAPTERS

DESIGNED TO MATE WITH ANY CUSTOM FLANGE

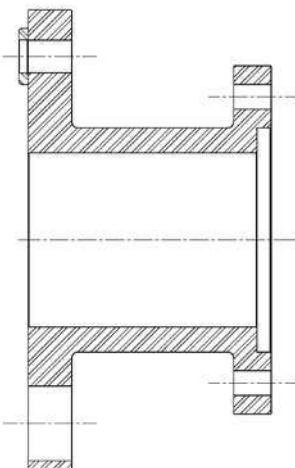

OVERSIZE HUB DESIGN

FOR INCREASED BORE CAPACITY

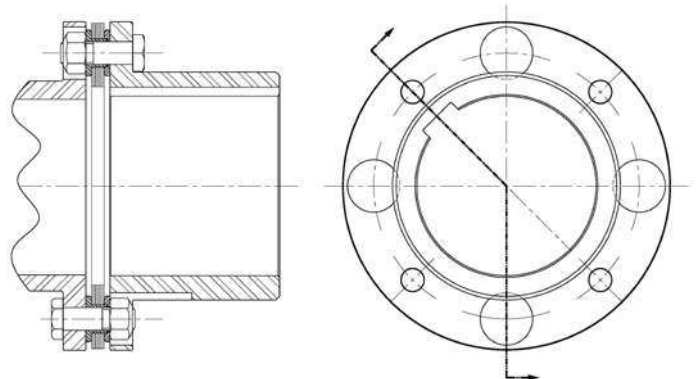



Coupling Design Options and Special Applications

ELECTRICAL INSULATION SPACER WITH SPLINE BORE AND EXTERNAL LOCKING ELEMENT

Two piece spacer design with e-glass composite tube separating the steel halves.

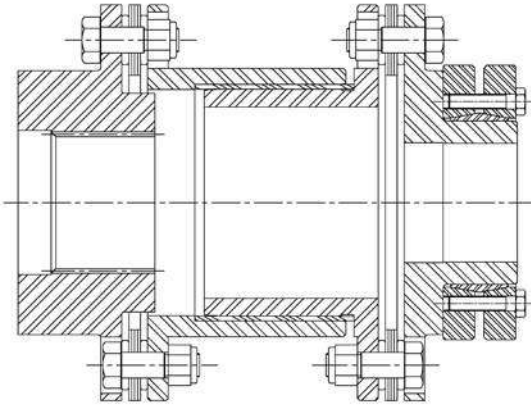

INERTIA RING ADDED TO TORSIONALLY TUNE COMPRESSOR SYSTEM

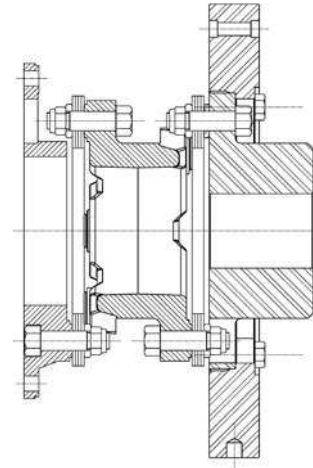

DESIGN WITH FLANGE TO FLANGE MOUNTING

Flanges designed to bolt to customer pilot and bolt pattern for test stand application.

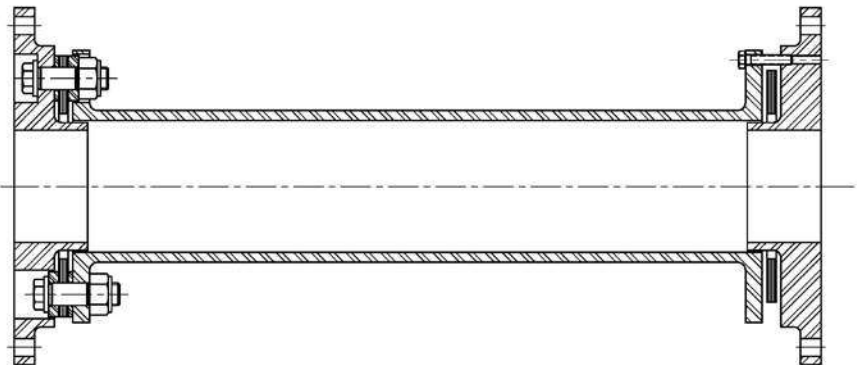

FLOATING SHAFT COUPLING WITH OVER SIZED TUBE FOR INCREASED STIFFNESS AND CRITICAL SPEED WITH CUSTOM FLANGE ADAPTER

Special features include oversize steel tube welded to bolted adapters for easy assembly, motor hub with integral brake disc, custom flange.

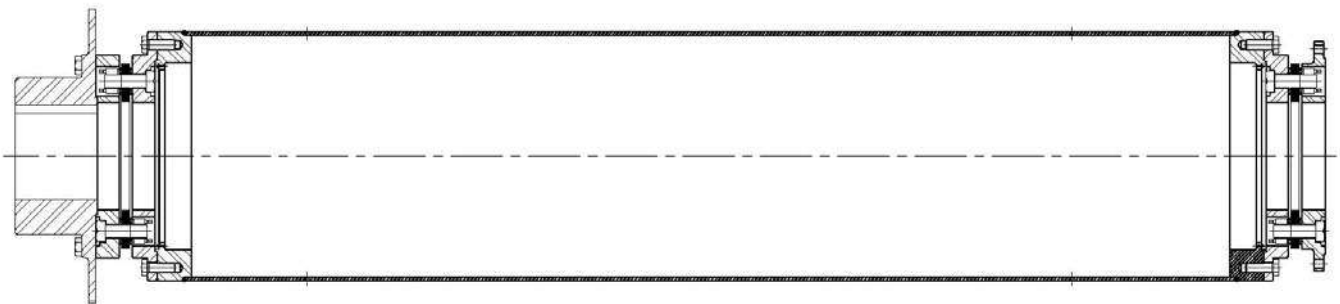

Coupling Design Options and Special Applications



Riddhi Engineering Company

www.couplings-mounts.com

sales@riddhiengineeringco.com

+91 74900 32784

MULTI-SHAFT ASSEMBLY FOR VERICAL PUMPING STATIONS USING COMPOSITE TUBE TECHNOLOGY

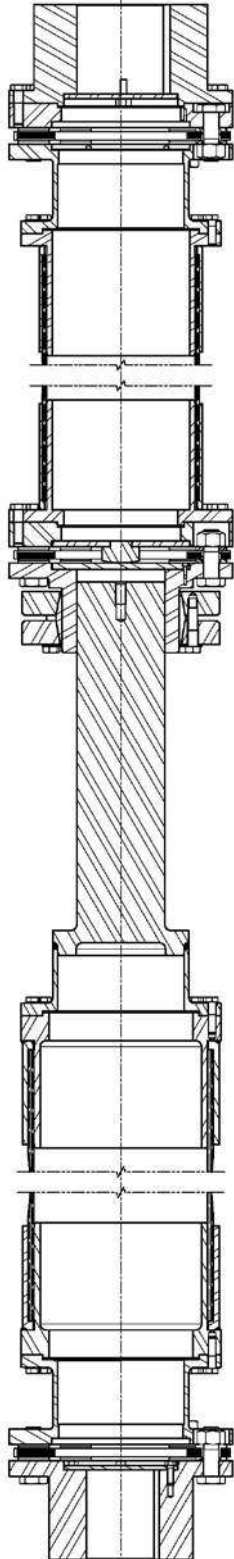

Disc, Bolt Thread and Tool Size Identification Chart

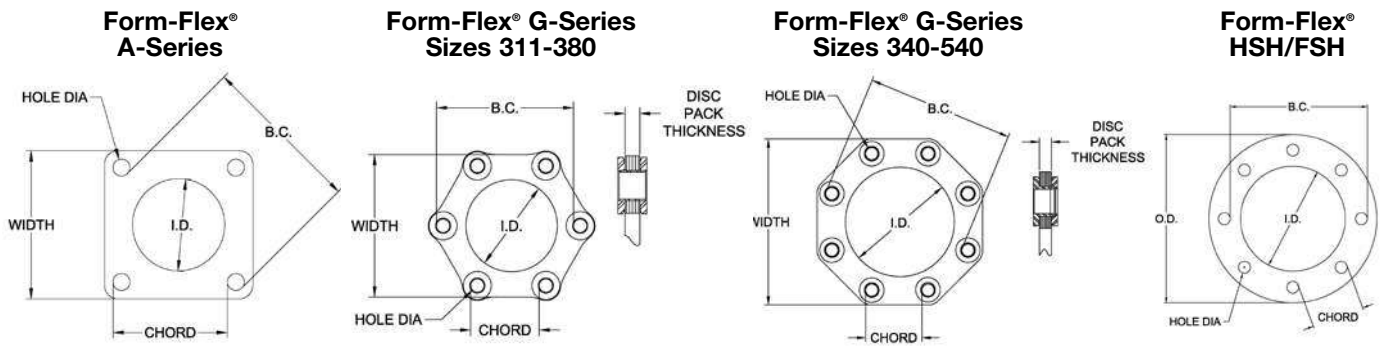

Coupling Series	Disc Size	Disc Dimensions (mm)						Bolt				Nut	
		Width	ID	Hole Dia.	B.C. Dia.	Chord	Disc Pack Thickness	Thread Diameter (mm)	Thread Pitch	Thread Designation	HEX WAF (in)	HEX WAF/OD (in)	Wrench Torque (Nm)
Form-Flex A-Series	5	46.6	25.5	6.4	47.7	33.3	1.5	6.4	28	1/4-28	0.438	0.438	11
	10	55.5	29.7	6.4	60.1	42.9	2.3	6.4	28	1/4-28	0.438	0.438	11
	15	64.5	32.4	8.0	68.4	47.6	3.0	7.9	24	5/16-24	0.500	0.500	23
	20	72.1	41.9	8.0	79.3	55.6	3.6	7.9	24	5/16-24	0.500	0.500	23
	25	89.5	45.2	11.2	95.2	66.7	3.8	11.1	20	7/16-20	0.625	0.625	54
	30	101.8	51.1	12.8	108.1	76.2	5.3	12.7	20	1/2-20	0.750	0.750	79
Form-Flex G-Series	35	119.7	68.9	12.8	133.3	93.7	6.9	12.7	20	1/2-20	0.750	0.750	79
	311	121.3	90.9	9.8	123.4	61.9	5.1	7.9	24	5/16-24	0.500	0.500	30
	321	136.5	94.6	13.0	133.4	66.7	6.3	11.1	20	7/16-20	0.625	0.688	75
	332	152.3	98.4	16.3	147.6	73.0	8.0	14.3	18	9/16-18	0.813	0.813	163
	346	176.1	120.6	16.3	173.0	85.7	8.0	14.3	18	9/16-18	0.813	0.813	163
	380	204.5	128.5	22.0	189.9	95.3	9.9	19.1	16	3/4-16	1.125	1.125	390
	340	190.4	124.6	15.9	171.4	65.1	6.1	12.7	20	1/2-20	0.875	0.875	102
	412	244.1	154.9	25.4	216.0	82.6	9.9	19.1	16	3/4-16	1.250	1.250	339
	419	279.7	177.8	29.0	247.7	95.3	12.6	25.4	14	1-14	1.625	1.625	610
	424	342.7	225.9	30.5	305.0	117.5	12.6	25.4	14	1-14	1.625	1.625	610
	444	382.5	243.8	36.5	335.0	128.6	14.5	28.6	12	1 1/8-12	1.813	1.813	881
	456	420.8	270.7	39.5	370.0	141.3	17.5	31.8	12	1 1/4-12	2.000	2.000	1125
	483	454.6	293.1	42.5	400.0	152.4	19.4	34.9	12	1 3/8-12	2.188	2.188	1355
	511	516.9	342.9	44.3	458.8	176.2	23.6	38.1	12	1 1/2-12	2.375	2.364	1898
520	588.9	370.6	56.1	513.1	196.9	29.0	47.6	12	1 7/8-12	3.000	0.438	146	
525	633.7	397.3	59.8	551.2	211.1	30.5	50.8	12	2-12	3.125	0.438	168	
530	663.4	415.0	63.5	576.6	220.7	32.0	54.0	12	2 1/8-12	3.375	0.438	191	
540	792.8	537.1	67.3	712.5	273.1	40.0	57.2	10	2 1/4-12	3.750	0.563	266	
Form-Flex HSH/FSH	22	142.9	97.9	8.3	120.7	46.0	4.6	7.9	24	5/16-24	0.500	0.500	34
	26	166.8	111.8	10.3	139.7	54.0	5.6	9.5	24	3/8-24	0.563	0.563	41
	31	196.9	133.4	11.9	165.1	63.5	6.4	11.1	20	7/16-20	0.625	0.625	54
	35	219.1	146.1	13.5	184.2	69.9	7.4	12.7	20	1/2-20	0.813	0.750	95
	37	244.5	160.3	15.9	203.2	77.8	8.3	14.3	18	9/16-18	0.938	0.875	129
	42	266.7	171.5	17.5	219.1	84.1	8.0	15.9	18	5/8-18	1.063	0.938	169
	45	285.8	184.2	19.1	235.0	90.5	9.6	15.9	18	5/8-18	1.125	1.063	203
	50	325.4	215.9	22.2	266.7	101.6	11.8	19.1	16	3/4-16	1.250	1.250	285
	55	365.1	228.6	25.4	298.5	114.3	13.7	22.2	14	7/8-14	1.375	1.438	434
	60	404.8	252.4	28.6	330.2	127.0	15.1	25.4	14	1-14	1.625	1.625	610
	70	460.4	282.6	33.3	374.7	142.9	19.8	28.6	12	1 1/8-12	1.750	1.813	780
	75	500.9	304.8	36.5	406.4	155.6	20.3	31.8	12	1 1/4-12	1.938	2.000	1125
	80	544.5	333.4	39.7	441.4	168.3	20.6	34.9	12	1 3/8-12	2.125	2.188	1356
	85	581.0	355.6	44.5	469.9	179.4	22.2	38.1	12	1 1/2-12	2.500	2.375	1898
	92	631.8	381.0	47.7	508.0	193.7	25.6	38.1	12	1 1/2-12	2.500	2.375	1898
	92HT	631.8	381.0	47.7	508.0	193.7	25.6	44.5	12	1 3/4-12	2.500	2.750	3254



Riddhi Engineering Company

www.couplings-mounts.com

sales@riddhiengineeringco.com

+91 74900 32784

Application Data Sheet

Project Ref: _____

Company: _____ Date: _____

Contact: _____ Email: _____

Replacing: _____ Phone #: _____

SECTION I - DRIVER	Electric Motor <input type="checkbox"/> ; Engine <input type="checkbox"/> - # Cylinders _____ ; Turbine <input type="checkbox"/> ; Other _____
HP: _____	KW: _____ Normal Torque: _____ Lb-in [] Nm []
Rated Speed: _____	Max Torque: _____ Lb-in [] Nm []
Operating Speed: _____	Breakdown Torque: _____ Lb-in [] Nm []

SECTION II - DRIVEN	Description: _____
Load Application: Non-Pulsating <input type="checkbox"/> Medium Pulsating <input type="checkbox"/> Heavy Pulsating <input type="checkbox"/> Smooth <input type="checkbox"/> Light Shock <input type="checkbox"/> Heavy Shock <input type="checkbox"/>	

SECTION III - COUPLING APPLICATION	Min Service Factor: _____
Temperature Range: _____ to _____ °C [] or °F []	Hydraulic Removal: Yes <input type="checkbox"/> No <input type="checkbox"/>
Specification: API671 <input type="checkbox"/> Edition _____ ; API610 <input type="checkbox"/> Edition _____ ; Other _____	
Balance: Cplg <input type="checkbox"/> Hubs <input type="checkbox"/> Spacer <input type="checkbox"/>	Balance Specification _____

SECTION IV - DIMENSIONAL DATA	Distance Between Shaft Ends (DBSE): _____ IN [] MM []
Taper Shaft & Keyway Data	
Driver	Driven
Shaft Dia (Straight): _____	_____
Shaft Dia L.E. (Taper): _____	_____
Taper Ratio _____	_____
Keyway Size: Width _____ Depth _____	Width _____ Depth _____
KW Depth Across Bore: _____	_____

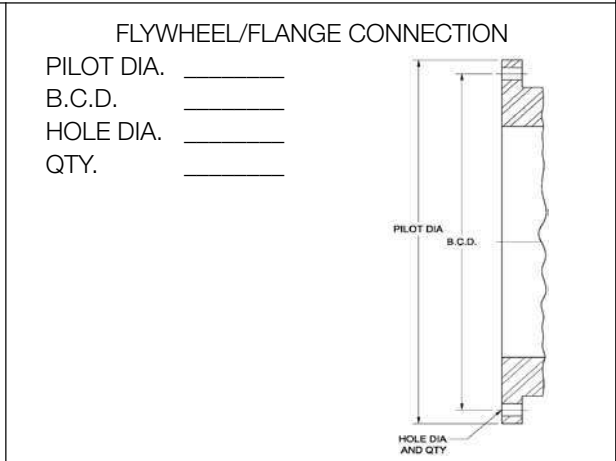
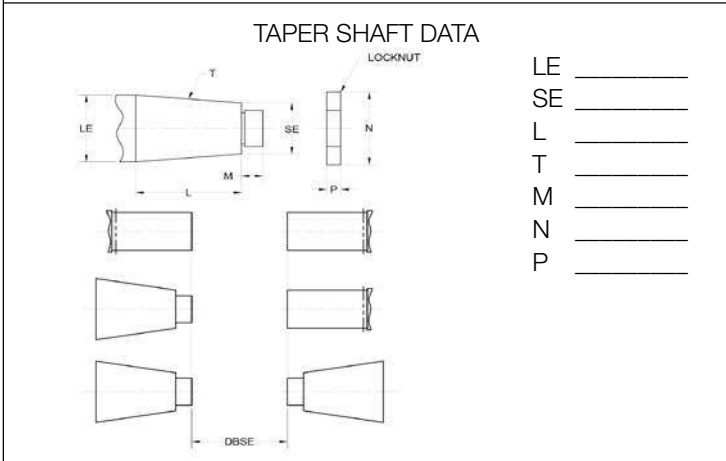

STANDARD ADAPTER SIZES

Size	O.D. (in)	SAE Bolting			HD Bolting		
		P.C.D. (in)	Hole Qty.	Hole Size (in)	P.C.D. (in)	Hole Qty.	Hole Size (in)
10	10.375	9.625	6	0.406	9.500	8	0.469
12	12.375	11.625	8	0.406	11.500	8	0.531
14	13.875	13.125	8	0.406	12.500	8	0.656
18	18.375	17.250	8	0.531	16.750	8	0.781
20	20.375	19.250	8	0.531	18.500	8	0.906
22	22.500	21.375	6	0.656	20.500	8	1.031
26	26.500	25.250	12	0.656	24.500	12	1.031
28	28.875	27.250	12	0.781	26.875	12	1.031

Riddhi Engineering Company
www.couplings-mounts.com
sales@riddhiengineeringco.com
 +91 74900 32784

Application Data Sheet

Additional Comments: _____

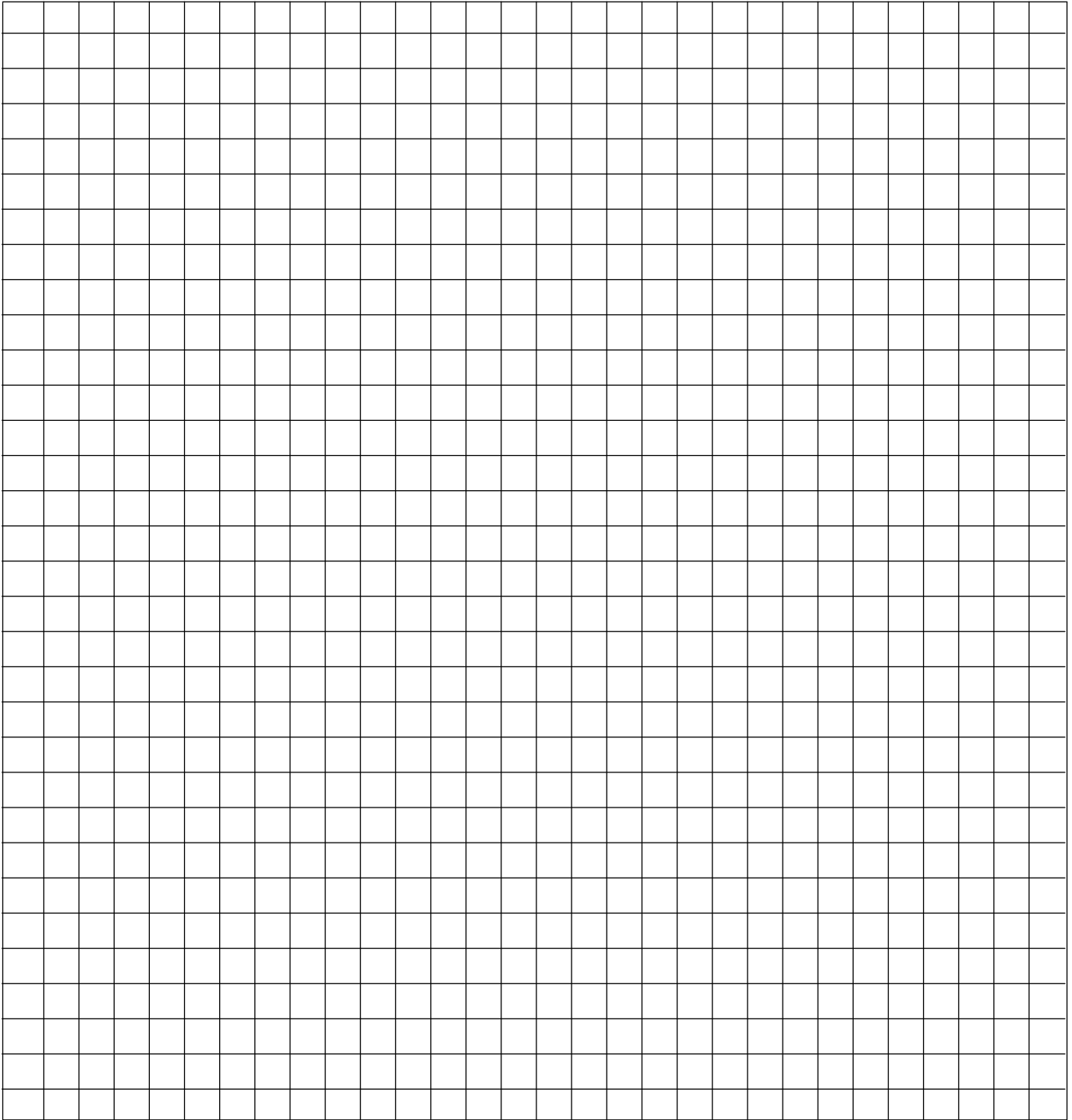

Sketch Area



Riddhi Engineering Company

www.couplings-mounts.com

sales@riddhiengineeringco.com

+91 74900 32784

Premier Industrial Company Leading Brands

OTHER PRODUCT SOLUTIONS FROM **ALTRA MOTION**

Our comprehensive product offerings include various types of clutches and brakes, overrunning clutches, engineered bearing assemblies, gearing and gear motors along with linear motion products, belted drives, couplings, limit switches, precision motors, drives & controls, miniature motors and engine braking systems. With thousands of product solutions available, Altra provides true single source convenience while meeting specific customer requirements. Many major OEMs and end users prefer Altra products as their No. 1 choice for performance and reliability.

WWW.ALTRAMOTION.COM



Electric Clutches & Brakes

Inertia Dynamics
Matrix
Stromag
Warner Electric



Precision Motors & Automation

Kollmorgen



Heavy Duty Clutches & Brakes

Industrial Clutch
Stromag
Svendborg Brakes
Twiflex
Wichita Clutch



Miniature Motors

Portescap



Overrunning Clutches

Formsprag Clutch
Marland Clutch
Stieber



Linear Systems

Thomson



Engineered Couplings & Universal Joints

Ameridrives
Bibby Turboflex
Guardian Couplings
Huco
Lamiflex Couplings
Stromag
TB Wood's



Engine Braking Systems

Jacobs Vehicle Systems



Gear Drives & Gear Motors

Bauer Gear Motor
Boston Gear
Delroyd Worm Gear
Nuttall Gear



Specialty Components

Kilian
Stromag
TB Wood's



Riddhi Engineering Company

www.couplings-mounts.com

sales@riddhiengineeringco.com

+91 74900 32784



The Brands of Altra Motion

Couplings

- Ameridrives
- Bibby Turboflex
- Guardian Couplings
- Huco
- Lamiflex Couplings
- Stromag
- TB Wood's

Linear Systems

- Thomson

Geared Cam Limit Switches

- Stromag

Engineered Bearing Assemblies

- Kilian

Electric Clutches & Brakes

- Matrix
- Stromag
- Warner Electric

Belted Drives

- TB Wood's

Heavy Duty Clutches & Brakes

- Twiflex
- Stromag
- Svendborg Brakes
- Wichita Clutch

Gearing & Specialty Components

- Bauer Gear Motor
- Boston Gear
- Delevan
- Delroyd Worm Gear
- Nuttall Gear

Engine Braking Systems

- Jacobs Vehicle Systems

Precision Motors & Automation

- Kollmorgen

Miniature Motors

- Portescap

Overrunning Clutches

- Formsprag Clutch
- Marland Clutch
- Stieber



Riddhi Engineering Company

www.couplings-mounts.com
 sales@riddhiengineeringco.com
 +91 74900 32784



Altra Couplings Group

TB Wood's
 1-888-829-6637 – Press #5
 +44 (0) 1992 501900

Bibby Turboflex
 +44 (0) 1924 460801
 1-800-779-6993

Huco
 1-888-829-6637 – Press #5
 +44 (0) 1992 501900

Ameridrives
 1-920-593-2444
 +44 (0) 1924 460801
 1-814-480-5000

Lamiflex Couplings
 +55 11 5679 6553
 +55 11 5679 7735

Guardian Couplings
 1-219-874-5248