



# SPINPLUS



## TECHNIQUE

### Hard to beat in terms of lightness

Light and slim, it is the ideal precision coupling for highly dynamic applications. Whether it is precisely positioned, assembled or measured - this lightweight is ideal in any situation.

### Lowest mass moment of inertia and extremely compact

When developing the Spinplus, the focus was placed on achieving the

lowest possible mass moment of inertia for the coupling.

This was achieved thanks to the unique function element manufactured through the modern MIM process, which allows universal displacement compensation on one level. As a result, the technical advantage lies in the very compact design of the backlash-free coupling and high power density, combined with a minimised mass moment of inertia.

This makes it ideal for highly dynamic and increasingly energy-efficient drive solutions.

### Precise, torsionally stiff and backlash-free

In the design of the FEM-optimised function element, the focus was placed on optimal weighting from high torque transmission, torsional stiffness and universal displacement capacity.

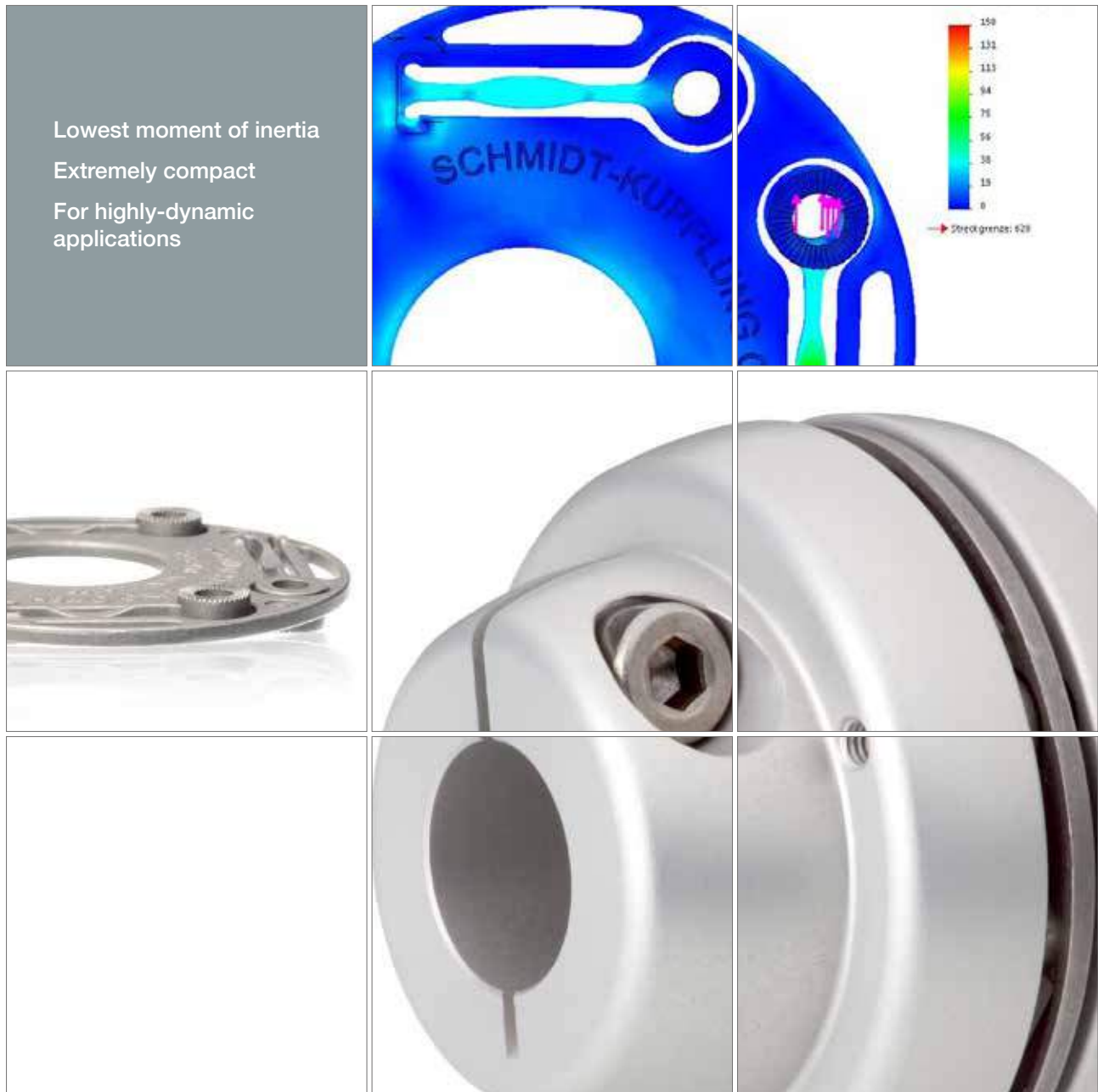

## VERSIONS

### Innovative hub design - optimised mass moment of inertia

In addition to the coupling design, which already has an optimised mass moment of inertia, the newly developed and innovative hub design (international design protecti-

on) highlights further optimisation of the lowest mass moment of inertia concept. These clamp hubs reduce the mass moment of inertia significantly compared to conventional hubs. To adapt to the respective application requirements,

two hub versions have therefore been designed. Version A provides the lowest possible mass moment of inertia, Version B is designed to accommodate large shaft diameters and focuses on the most compact dimensions.



Version A



Version B

#### Version A

This line with offset hub offers the lowest possible mass moment of inertia.

#### Version B

This line is designed to accommodate large shaft diameters and focuses on the most compact dimensions.

## MATERIAL

Clamp screws: DIN 912 12.9

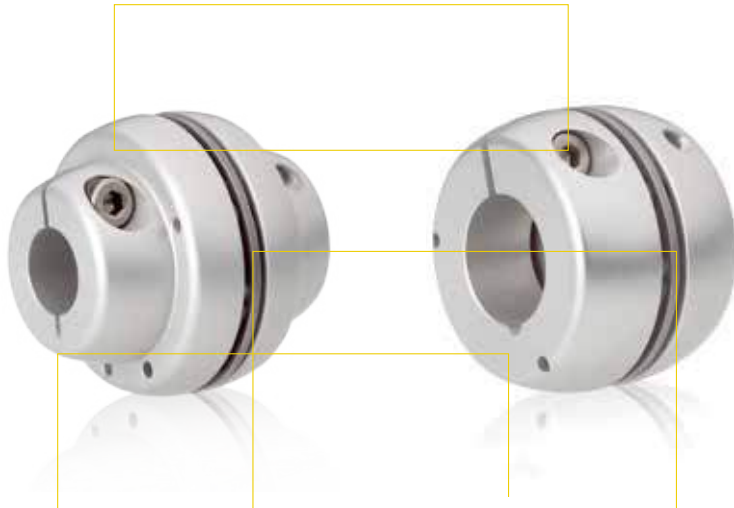

Function element: highly specialised steel with improved flexural capability

Clamp hubs: high-strength aluminium 3.2315  
AlMgSi1  
Surface: anodized

## SELECTION SEQUENCE

When selecting your Spinplus, the various technical parameters play a crucial role. Parameters such as maximum speed values, occurring shaft misalignments and driving torque must be considered.

### Application fields: Highly-dynamic servo motors

1. Spinplus main fields of application are dynamic servo motors. The Spinplus design is performed by multiplying the servo motor highest peak torque  $T_{AS}$ , to be regularly transmitted, by the impact or load factor K.

$$T_{KN} \geq T_{AS} \times K \quad (\text{Nm})$$

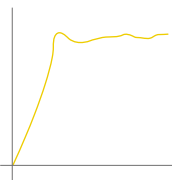
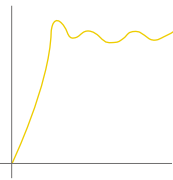
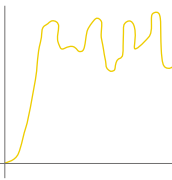
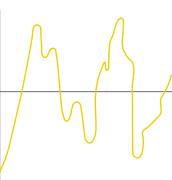
Load factor K			
Constant	Vibrations: Small	Vibrations: Medium	Vibrations: Large
			
1,0	1,25	1,75	2,25

In practice, the following formula has been proven:

$$T_{KN} \geq T_{AS} \times (1,2 - 1,5) \quad (\text{Nm})$$

2. For each selected coupling size, please observe the maximum permissible bore diameters and the corresponding misalignment capacity. For these values, please refer to the table of the relevant coupling size. The shaft misalignment values specified in the catalogue are maximum values. In case of combined misalignments, they must be adjusted in such a way that the sum of the actual misalignment percentages does not exceed 100%.
3. As a general rule: The coupling speed must not exceed the max. permissible speed indicated in the catalogue.

### Application fields: High-resolution encoders

Another main fields of applications are high-resolution encoders. With encoder applications, only very low torques occur which mostly fall within the Ncm range. Therefore, in encoder applications, the influence of above mentioned torque values on the selection formula is to be regarded as low.

### Temperature range

-30°C bis +120°C

## SPINPLUS

### Version A

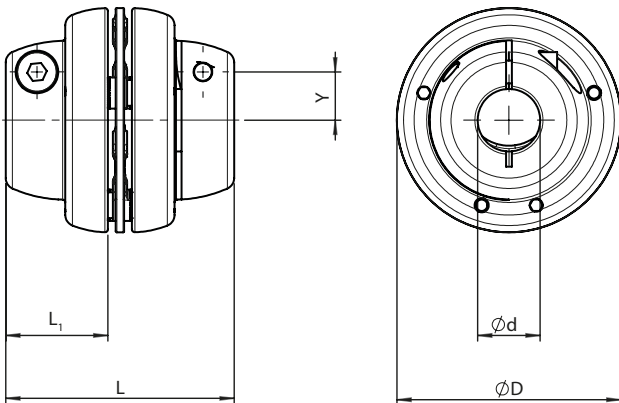

### Version B

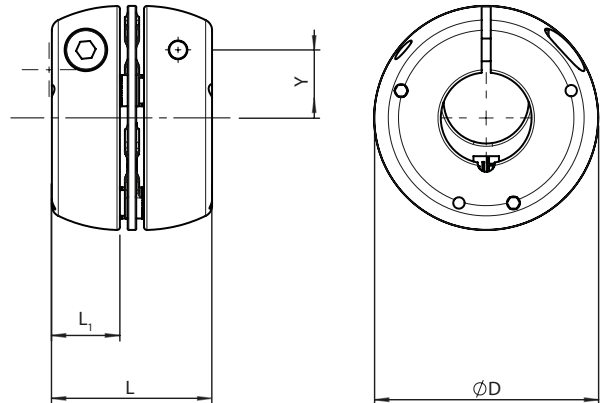

## Specifications

Modell	J gcm <sup>2</sup>	D mm	L mm	L <sub>1</sub> mm	M mm	T <sub>A</sub> Nm	Y mm	m g	d <sub>max</sub> mm	T <sub>KN</sub> Nm	C <sub>T</sub> Nm/rad	max. rpm min <sup>-1</sup>	Misalignment		
													angular °	radial mm	axial mm
SP4-A	30	29,5	30	13,5	M3	1,5	5,8	32	8	4	1.350	16.000	1	0,15	0,2
SP4-B	37		21	9			8,5	27	14						
SP10-A	125	39,5	40	18	M4	3	8,5	84	12	10	1.820	12.000	1	0,2	0,3
SP10-B	154		28	12			12	74	18						
SP30-A	800	59,5	51	23	M5	6	13	185	18	30	3.500	8.000	1	0,3	0,3
SP30-B	880		39	17			19	158	28						

J= Moment of inertia, C<sub>T</sub>= Torsional stiffness, D= Outer diameter, L= Coupling length, d<sub>max</sub>= Max. bore diameter

## Bore diameters

Modell	d mm														
	5	6	8	9	10	11	12	14	16	18	19	20	24	25	28
SP4-A	■	■	■												
SP4-B			■	■	■	■	■	■							
SP10-A		■	■	■	■	■	■								
SP10-B						■	■	■	■	■					
SP30-A						■	■	■	■	■					
SP30-B							■	■	■	■	■	■	■	■	■

Please consider: Hybrid types of Version A and Version B are not provided.

Ordering example:

### SP10-A Ø8 Ø10

Spinplus SP10-A, bore 8 mm, 10 mm

## MOUNTING

Spinplus couplings are generally installed as complete units. Bores are supplied in fit G7.

1. Confirm the clamping bolts are loosened. Remove the rust, dust and oil content on the inside diameter surface of the shaft and coupling. (Wipe off the oil content completely with a waste cloth, etc.)
2. Insert the coupling into the shaft. At this time, do not apply more than necessary force such as compression or pulling to the element part of the coupling. After the coupling is mounted into the second shaft, do not apply excessive compression when inserting the coupling into the mating shaft. Confirm the two clamping bolts are loosened and the coupling is movable to the axial and rotative directions.
3. Make sure that the insertion length of the coupling into the shaft is kept in the position so that the target shaft is in contact with the entire tightening zone of the coupling. Please make sure that the shafts do not extend into the functional area of the coupling.
4. Tighten up clamp screws with full tightening torque. For the tightening process please make sure using an appropriate torque wrench.

## PRODUCT OVERVIEW



Catalogue Spinplus

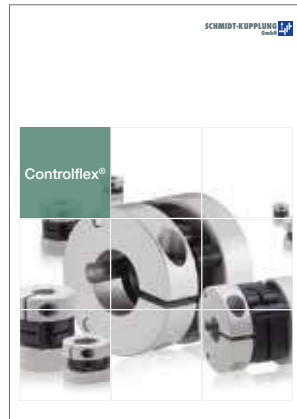

Catalogue Controlflex



Catalogue Semiflex



Catalogue Schmidt-Kupplung



Catalogue Servoflex



Catalogue Loewe GK

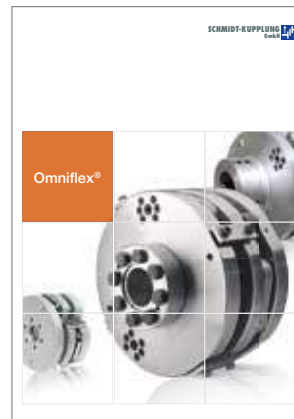

Catalogue Omniflex



Overview Industries

## CONTACT

SCHMIDT-KUPPLUNG GmbH  
Wilhelm-Mast-Straße 15  
38304 Wolfenbüttel

Tel.: 05331 9552 500  
Fax: 05331 9552 552



Riddhi Engineering Company

[www.couplings-mounts.com](http://www.couplings-mounts.com)  
[sales@riddhiengineeringco.com](mailto:sales@riddhiengineeringco.com)  
+91 74900 32784