

METAFLEX COUPLING SERIES 80

- * Coupling specially designed for Petrochemical Industry
- * Special shape of Discs to ensure Pure Tensile load
- * Higher Flexibility with better Torque Ratings
- * Unitised Disc Packs
- * Drop Down Central Spacer Assembly with piloted Flanges
- * Larger Bore Capacities
- * Can be furnished to API 610 / API 671 requirements

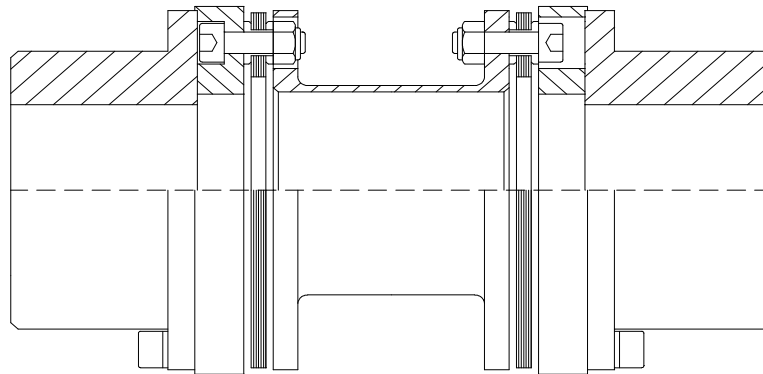

Type A - Sizes 65,80,100,125

Type B - Sizes 150,162,180,200,220,250,300

Type C - Sizes 225,262,312 & Larger

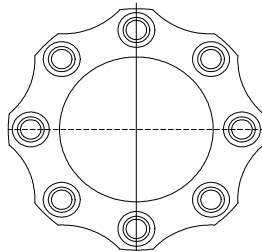
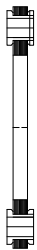

Type C

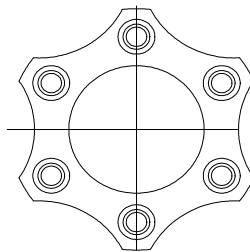

Type B

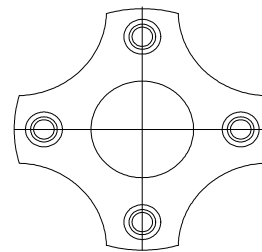

Type A



Riddhi Engineering Company

www.couplings-mounts.com

sales@riddhiengineeringco.com

+91 74900 32784

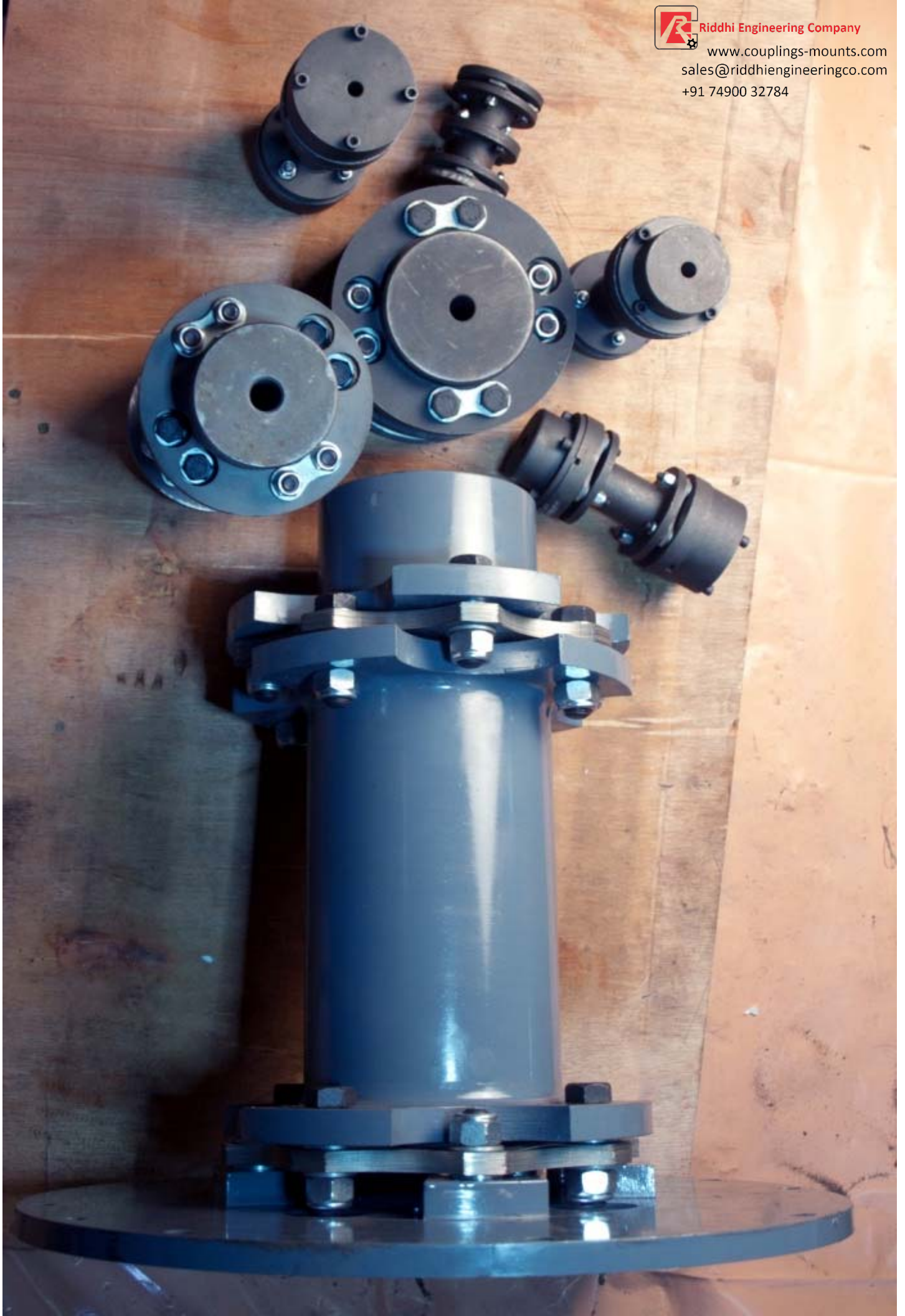



Selection Procedure Metaflex Flexible Disc Coupling

Step 1- Determine required HP/100 RPM rating as follows :

$$\text{Required HP/100 rpm} = P * 100 * SF / N$$

Where P is primemover Power in HP , SF is service factor

N is operating RPM

Step 2 – if selected coupling by step 1 has HP/100 RPM > required HP/100 rpm , selection is tentatively OK . Otherwise select higher size coupling with adequate HP/100 rpm rating.

Step 3 – a) Check max bore is within Max bore capacity. Please note higher bore capacity are possible in series 80SP/80SPL/80X-SP/80X-SPL for a given size. Hubs can also be specially designed to accommodate higher bore.

- Check Max speed is within max permissible length
- For types 80SN/80SF/80SV/80SVA check critical whirling speed is safe distance away from operating speed
- For reciprocating machines viz Diesel Drive/ Reciprocating compressor drives it is advisable to carry out TV analysis of the system. Unique can provide this service on request .

Service Factors

Duty		Type of Prime Mover		
Load	Driven Equipment	Motor/ turbine	Hydraulic Diesel – 8 or more cylinder	Recipro- cating engine 6 cyl
Uniform	Centrifugal Pumps liquid , Blowers	1.0	1.50	2.00
Light Shock	Centrifugal pumps slurry , Agitators Compressor- lobe/vane/screw Conveyors – uniform load, Generators , Rotary Pumps – Gear , Lobe , Vane. , Rotary Screen, Reel (Paper) , Line shaft , Fans light duty Line Shafting	1.50	2.00	2.50
Medium Shock	Bucket elevator, Plastic extruder, Metallic extruder, Large Fans, Machine tools – light , Paper – Calender/Press/Couch/Dryer / stacker Reciprocating pump – 3 cyl or more single acting/ 1-2 cyl double acting Sheeter , Textile calender	2.0	2.50	3.00
Heavy Shock	Cane Knife, Machine tool – heavy , Paper mill barker , Rec Pump 1-2 cyl single acting, Rubber extruder/mill Vibratory Screen	2.5	3.00	3.50
Extreme Shock	Crushers , Banbury Mixer , Bar stock Shear	3.0	3.5	4.0

For 4 cyl Diesel drive add 0.50 to SF for 6 cylinder engine drives

For less than 4 cylinder Diesel engine – consult us

For Reciprocating Compressors – consult us

Unique Transmission (India) Pvt Ltd



Metaflex Coupling Selection Chart Series 80 /80SPL/80X/80XSPL

For 3000 RPM Motors			
Motor KW	Motor shaft dia*Length	Series	Size
1.5	24*50	80/80X	80
2.2	28*60	80/80X	80
3.7	28*60	80/80X	80
5.5	38*80	80/80X	80
7.5	38*80	80/80X	80
11	42*110	80/80X	100
15	42*110	80/80X	100
18.5	48*110	80SPL/80XSPL	100
22	48*110	80SPL/80XSPL	100
30	55*110	80SPL/80XSPL	125
37	55*110	80SPL/80XSPL	125
45	55*110	80	162
55	60*140	80SPL/80XSPL	162
75	65*140	80SPL/80XSPL	162
90	65*140	80SPL/80XSPL	162
110	65*140	80/80X	180
132	65*140	80/80X	180
160	70*140	80/80X	200
200	70*140	80/80X	220
250	75*140	80/80X	225
315	80*170	80/80X	250
492	90*170	80/80X	262
750	90*170	80/80X	300
1000	110	80Q/80QX	300
1200	110	80Q/80QX	300

For 1500 RPM Motors			
Motor KW	Motor shaft dia*Length	Series	Size
1.5	24*50	80/80X	80
2.2	28*60	80/80X	80
3.7	28*60	80/80X	80
5.5	38*80	80/80X	80
7.5	38*80	80/80X	100
11	42*110	80/80X	100
15	42*110	80/80X	125
18.5	48*110	80/80X	125
22	48*110	80/80X	150
30	55*110	80/80X	162
37	60*140	80SPL/80XSPL	162
45	60*140	80SPL/80XSPL	162
55	65*140	80/80X	180
75	75*140	80SPL/80XSPL	200
90	75*140	80/80X	220
110	80*170	80/80X	220
132	80*170	80/80X	250
160	90*170	80/80X	250
200	90*170	80/80X	262
250	100*210	80/80X	300
315	110*210	80/80X	300
500	110*210	80Q/80QX	300
650	110*210	80Q/80QX	350
1000	125	80Q/80QX	375
1250	125	80Q/80QX	425

For close coupling application Series 80CC

For 3000 RPM Motors			
Motor KW	Motor shaft dia*Length		Series-Size
1.5	24*50		80CC-125
2.2	28*60		80CC-162
3.7	28*60		80CC-162
5.5	38*80		80CC-162
7.5	38*80		80CC-162
11	42*110		80CC-162
15	42*110		80CC-162
18.5	48*110		80CC-200
22	48*110		80CC-200
30	55*110		80CC-220
37	55*110		80CC-220
45	55*110		80CC-220
55	60*140		80CC-220
75	65*140		80CC-250
90	65*140		80CC-250
110	65*140		80CC-250
132	65*140		80CC-250
160	70*140		80CC-250
200	70*140		80CC-250
250	75*140		80CC-262
315	80*170		80CC-312
492	90*170		80CC-312
750	90*170		80CC-312
850	100*110		80CC-375
1150	110		80CC-375

For 1500 RPM Motors			
Motor KW	Motor shaft dia*Length		Series-Size
1.5	24*50		80CC-125
2.2	28*60		80CC-162
3.7	28*60		80CC-162
5.5	38*80		80CC-162
7.5	38*80		80CC-162
11	42*110		80CC-162
15	42*110		80CC-162
18.5	48*110		80CC-200
22	48*110		80CC-200
30	55*110		80CC-220
37	60*140		80CC-220
45	60*140		80CC-220
55	65*140		80CC-250
75	75*140		80CC-262
90	75*140		80CC-262
110	80*170		80CC-312
132	80*170		80CC-312
160	90*170		80CC-312
200	90*170		80CC-312
250	100*210		80CC-375
315	110*210		80CC-375
500	110*210		80CC-375
650	110*210		80CC-375
800	120		80CC-425
900	125		80CC-450
1250	125		80CC-450

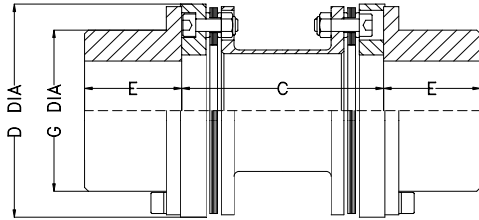

**Metaflex
Coupling
Series 80**

Size	Nominal HP/100 RPM	Rating Torque NM	Peak Torque NM	Max Speed RPM	Max Bore MM	E, Hub Length MM	D Dia MM	G Dia MM	Std C MM
65	0.45	32	64	25000	28	28	66	42	100
80	0.9	64	128	25000	38	30	75	54	100
100	1.8	128	256	25000	42	32	87	60	100
125	2.6	185	370	20000	48	41	102	70	100
150	4	285	570	20000	48	45	105	69	100
162	7	500	1000	18000	55	48	115	80	140
180	9	640	1280	18000	65	55	130	90	140
200	12	855	1710	16000	70	54	143	100	140
220	15	1070	2140	16000	80	62	152	112	140
225	18	1282	2564	14600	75	67	150	110	140
250	25	1780	3560	12300	90	76	173	130	140
262	33	2350	4700	12300	90	76	173	130	140
300	56	3990	7980	11000	110	86	203	157	180
312	56	3990	7980	11000	110	86	203	157	180
350	70	4990	9980	10500	115	95	227	162	180
375	100	7125	14250	10000	130	102	252	187	200
425	140	9975	19950	8000	130	108	273	191	200
450	170	12110	24220	7000	145	114	293	211	250
500	270	19230	38460	6000	175	127	333	251	250
550	400	28500	57000	5360	190	148	373	270	300
600	500	35625	71250	4850	210	153	412	As reqd	300
700	800	57000	114000	4250	240	178	470	DO	325
750	1100	78375	156750	3920	270	191	510	DO	325
800	1600	114000	228000	3600	300	210	553	DO	350
Size	Mass KG	Inertia MR^2 KG.M^2	Maximum Misalignment		Torsional Stiff MNM/Rad	Axial Spring Rate N/MM	Bolt Tight Torque		
			AXIAL MM	RADIAL MM			# NM	## MM	
65	1.5	0.001	1	0.6	0.01	25	6	6	
80	2.1	0.002	1.2	0.6	0.02	30	10	6	
100	3.0	0.003	2	0.6	0.06	50	24	10	
125	4.7	0.007	2	0.8	0.06	60	24	24	
150	4.8	0.006	1.3	0.8	0.06	150	24	24	
162	6.6	0.011	1.3	1.2	0.18	100	24	24	
180	9.2	0.020	1.5	1.2	0.20	130	48	48	
200	11.0	0.030	1.8	1.2	0.20	165	48	48	
220	13.5	0.043	2.0	1.2	0.26	130	48	48	
225	14.5	0.044	1.4	1.2	0.26	275	48	48	
250	20.0	0.082	2.2	1.2	0.38	195	48	48	
262	20.0	0.082	1.5	1.2	0.44	350	48	48	
300	34.0	0.19	3.0	1.2	0.64	370	200	80	
312	30.0	0.17	1.9	1.2	0.64	415	80	80	
350	42.0	0.30	2.0	1.2	1.07	500	200	200	
375	55.0	0.47	2.3	1.5	1.38	540	200	200	
425	75.0	0.77	2.5	1.5	2.14	725	400	400	
450	97.0	1.15	2.8	1.7	2.36	755	400	400	
500	122.0	1.95	3.0	1.9	3.92	920	400	400	
550	155.0	3.00	3.2	2.1	5.64	920	540	540	
600	205.0	4.90	3.7	2.1	6.93	900	700	700	
700	314.0	9.80	4.1	2.4	11.3	1230	1400	1400	
750	395.0	14.20	4.6	2.4	15	1480	1800	1400	
800	580.0	26.00	5.0	2.6	ON REQ	ON REQ	2400	1400	

Mass , Inertia, Stiffness are at max bore with standard spacer dimension C listed above. Other C dimension are available as required on request .Hub dimensions can be modified to suit special needs.
 Max angular misalignment 0.50 Deg /Pack .Misalignment limits are for speeds upto 3000 RPM. For higher Speeds consult us . Bolt Tightening Torques - # for Disc Pack Bolts , ## for Hub Bolts .

**Metaflex
Coupling
Series 80 SPL**

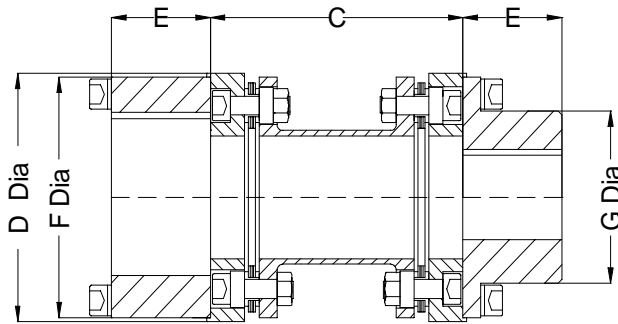

Size	Nominal HP/100 RPM	Rating Torque NM	Peak Torque NM	Max Speed RPM	Max Bore D1 MM	Max Bore D2 MM	D Dia MM	G Dia MM	F Dia MM	E, Hub Length MM	Std C MM
65	0.45	32	64	25000	28	42	66	42	63	28	100
80	0.9	64	128	25000	38	48	75	54	72	30	100
100	1.8	128	256	25000	42	55	87	60	83	32	100
125	2.6	185	370	20000	48	65	102	70	98	41	100
150	4	285	570	20000	48	70	105	69	102	45	100
162	7	500	1000	18000	55	75	115	80	111	48	140
180	9	640	1280	18000	65	90	130	90	125	55	140
200	12	855	1710	16000	70	95	143	100	138	54	140
220	15	1070	2140	16000	80	102	152	112	148	62	140
225	18	1282	2564	14600	75	100	150	110	145	67	140
250	25	1780	3560	12300	90	115	173	130	168	76	140
262	33	2350	4700	12300	90	115	173	130	168	76	140
300	56	3990	7980	11000	110	140	203	157	198	86	180
312	56	3990	7980	11000	110	140	203	157	198	86	180
350	70	4990	9980	10500	115	155	227	162	221	95	180
375	100	7125	14250	10000	130	170	252	187	246	102	200
425	140	9975	19950	8000	130	185	273	191	273	108	200
450	170	12110	24220	7000	145	200	293	211	293	114	250
500	270	19230	38460	6000	175	230	333	251	333	127	250
Size	Mass KG	Inertia MR ² KG.M ²	Maximum Misalignment		Tor. Stiff MNM/Rad	Axial Spring Rate N/MM	Bolt Tight Torque				
			AXIAL MM	RADIAL MM			# NM	## MM			
65	1.6	0.001	1	0.6	0.01	25	6	6			
80	2.3	0.002	1.2	0.6	0.02	30	10	6			
100	3.2	0.003	2	0.6	0.06	50	24	10			
125	5.0	0.008	2	0.8	0.06	60	24	24			
150	5.3	0.008	1.3	0.8	0.06	150	24	24			
162	7.2	0.013	1.3	1.2	0.18	100	24	24			
180	9.7	0.025	1.5	1.2	0.20	130	48	48			
200	12.2	0.037	1.8	1.2	0.20	165	48	48			
220	15.1	0.052	2.0	1.2	0.26	130	48	48			
225	15.7	0.051	1.4	1.2	0.26	275	48	48			
250	21.5	0.099	2.2	1.2	0.38	195	48	48			
262	21.5	0.099	1.5	1.2	0.44	350	48	48			
300	36.0	0.222	3.0	1.2	0.64	370	200	80			
312	32.2	0.203	1.9	1.2	0.64	415	80	80			
350	46.0	0.370	2.0	1.2	1.07	500	200	200			
375	61.0	0.580	2.3	1.5	1.38	540	200	200			
425	85.0	0.990	2.5	1.5	2.14	725	400	400			
450	106.0	1.420	2.8	1.7	2.36	755	400	400			
500	137.0	2.470	3.0	1.9	3.92	920	400	400			

Mass, Inertia, Stiffness are at max bore with standard spacer dimension C listed above. Other C dimension are available as required on request. Hub dimensions can be modified to suit special needs. Max angular misalignment 0.50 Deg /Pack. Misalignment limits are for speeds upto 3000 RPM. For higher speeds consult us. Bolt Tightening Torques - # for Disc Pack Bolts, ## for Hub Bolts.

Unique Transmission (India) Pvt Ltd



**Metaflex
Coupling
Series 80 SP**

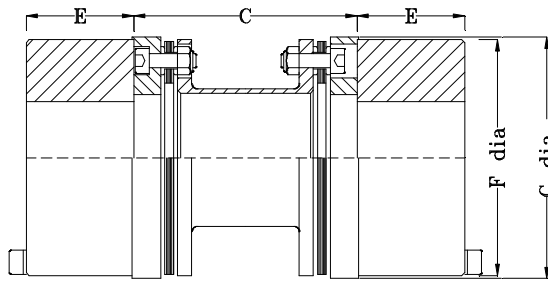

Size	Nominal HP/100 RPM	Rating Torque NM	Peak Torque NM	Max Speed RPM		Max Bore MM	D Dia MM	F Dia MM	E, Hub Length MM	Std C MM
65	0.45	32	64	25000		42	66	63	28	100
80	0.9	64	128	25000		48	75	72	30	100
100	1.8	128	256	25000		55	87	83	32	100
125	2.6	185	370	20000		65	102	98	41	100
150	4	285	570	20000		70	105	102	45	100
162	7	500	1000	18000		75	115	111	48	140
180	9	640	1280	18000		90	130	125	55	140
200	12	855	1710	16000		95	143	138	54	140
220	15	1070	2140	16000		102	152	148	62	140
225	18	1282	2564	14600		100	150	145	67	140
250	25	1780	3560	12300		115	173	168	76	140
262	33	2350	4700	12300		115	173	168	76	140
300	56	3990	7980	11000		140	203	198	86	180
312	56	3990	7980	11000		140	203	198	86	180
350	70	4990	9980	10500		155	227	221	95	180
375	100	7125	14250	10000		170	252	246	102	200
425	140	9975	19950	8000		185	273	273	108	200
450	170	12110	24220	7000		200	293	293	114	250
500	270	19230	38460	6000		230	333	333	127	250
Size	Mass KG	Inertia MR ² KG.M ²	Maximum Misalignment		Tor. Stiff MNm/Rad		Axial Spring Rate N/MM	Bolt Tight Torque		
			AXIAL MM	RADIAL MM				#	##	
								NM	MM	
65	2	0.001	1	0.6	0.017	25	6	6		
80	3	0.002	1.2	0.6	0.031	30	10	6		
100	4	0.004	2	0.6	0.044	50	24	10		
125	5	0.009	2	0.8	0.080	60	24	24		
150	6	0.010	1.3	0.8	0.130	150	24	24		
162	8	0.016	1.3	1.2	0.21	100	24	24		
180	11	0.030	1.5	1.2	0.27	130	48	48		
200	13	0.044	1.8	1.2	0.37	165	48	48		
220	17	0.062	2.0	1.2	0.47	130	48	48		
225	17	0.058	1.4	1.2	0.60	275	48	48		
250	23	0.115	2.2	1.2	0.80	195	48	48		
262	23	0.115	1.5	1.2	1.10	350	48	48		
300	38	0.254	3.0	1.2	1.40	370	200	80		
312	34	0.237	1.9	1.2	1.50	415	80	80		
350	51	0.440	2.0	1.2	2.80	500	200	200		
375	66	0.700	2.3	1.5	3.70	540	200	200		
425	95	1.220	2.5	1.5	5.80	725	400	400		
450	115	1.700	2.8	1.7	6.60	755	400	400		
500	152	3.000	3.0	1.9	11.00	920	400	400		

Mass , Inertia, Stiffness are at max bore with standard spacer dimension C listed above. Other

C dimension are available as required on request .Hub dimensions can be modified to suit special needs.

Max angular misalignment 0.50 Deg /Pack .Misalignment limits are for speeds upto 3000 RPM. For higher

Speeds consult us . Bolt Tightening Torques - # for Disc Pack Bolts , ## for Hub Bolts .

Unique Transmission (India) Pvt Ltd

10/ID Lal Bazar Street , Calcutta 700001

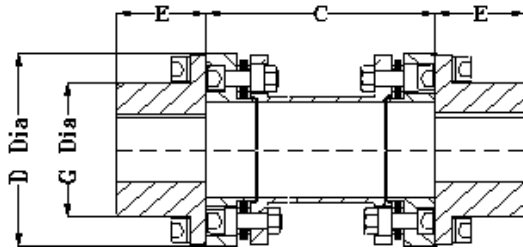

**METAFLEX
 COUPLING
 SERIES 80 X**

* meet API 610 requirements
 * can be supplied to API 671 on request

SIZE	NOMINAL HP/100 RPM	RATING TORQUE NM	PEAK TORQUE NM	MAX SPEED RPM	MAX BORE MM	E,HUB LENGTH MM	D DIA MM	G DIA MM	STD C MM
65	0.45	32	64	25000	28	28	66	42	100
80	0.9	64	128	25000	38	30	75	54	100
100	1.8	128	256	25000	42	32	87	60	100
125	2.6	185	370	20000	48	41	102	70	100
150	4	285	570	20000	48	45	105	69	100
162	7	500	1000	18000	55	48	115	80	140
180	9	640	1280	18000	65	55	130	90	140
200	12	855	1710	16000	70	54	143	100	140
220	15	1070	2140	16000	80	62	152	112	140
225	18	1282	2564	14600	75	67	150	110	140
250	25	1780	3560	12300	90	76	173	130	140
262	33	2350	4700	12300	90	76	173	130	140
300	56	3990	7980	11000	110	86	203	157	180
312	56	3990	7980	11000	110	86	203	157	180
350	70	4990	9980	10500	115	95	227	162	180
375	100	7125	14250	10000	130	102	252	187	200
425	140	9975	19950	8000	130	108	273	191	200
450	170	12110	24220	7000	145	114	293	211	250
500	270	19230	38460	6000	175	127	333	251	250
550	400	28500	57000	5360	190	148	373	270	300
600	500	35625	71250	4850	210	153	412	AS REQD	300
700	800	57000	114000	4250	240	178	470	DO	325
750	1100	78375	228000	3920	270	191	510	DO	325
800	1600	114000	302000	3600	300	210	553	DO	350
SIZE	MASS KG	INERTIA KG.M^2	MAX MISALIGNMENT		TORSIONAL STIFF MNM/RAD	AXIAL SPRING RATE N/MM	BOLT TORQUE		
			AXIAL MM	RADIAL MM			#	##	
							NM	MM	
65	1.5	0.001	1	0.6	0.01	25	6	6	
80	2.1	0.002	1.2	0.6	0.02	30	10	6	
100	3	0.003	2	0.6	0.06	50	24	10	
125	4.7	0.007	2	0.8	0.06	60	24	24	
150	4.8	0.006	1.3	0.8	0.06	150	24	24	
162	6.6	0.011	1.3	1.2	0.18	100	24	24	
180	9.2	0.020	1.5	1.2	0.20	130	48	48	
200	11.0	0.030	1.8	1.2	0.20	165	48	48	
220	13.5	0.043	2.0	1.2	0.26	130	48	48	
225	14.5	0.044	1.4	1.2	0.26	275	48	48	
250	20	0.082	2.2	1.2	0.38	195	48	48	
262	20	0.082	1.5	1.2	0.44	350	48	48	
300	34	0.19	3.0	1.2	0.64	370	200	80	
312	30	0.17	1.9	1.2	0.64	415	80	80	
350	42	0.30	2.0	1.2	1.07	500	200	200	
375	55	0.47	2.3	1.5	1.38	540	200	200	
425	75	0.77	2.5	1.5	2.14	725	400	400	
450	97	1.15	2.8	1.7	2.36	755	400	400	
500	122	1.95	3.0	1.9	3.92	920	400	400	
550	155	3	3.2	2.1	5.64	920	540	540	
600	205	4.9	3.7	2.1	6.93	900	700	700	
700	314	9.8	4.1	2.4	11.3	1230	1400	1400	
750	395	14.2	4.6	2.4	15	1480	1800	1400	
800	580	26	5.0	2.6	ON REQ	ON REQ	2400	1400	

THESE COUPLINGS HAVE CAPTURED CENTRE MEMBER THIS FEATURE PREVENTS SPACER SUB ASSEMBLY FROM FLYING OFF EVEN IN UNLIKELY EVENT OF DISC AS WELL AS BOLT FAILURE .

MASS AND INERTIA ,STIFFNESS ARE AT MAX BORE WITH STANDARD SPACER.DIMENSION C LISTED ABOVE.OTHER C DIMENSIONS ARE AVAILABLE AS REQUIRED ON REQUEST.HUB DIMENSIONS CAN BE MODIFIED TO SUIT SPECIAL NEEDS. MAX ANGULAR MISALIGNMENT 0.50 DEG/PACK.MISALIGNMENT LIMITS ARE FOR SPEEDS UPTO 3000 RPM.FOR HIGHER SPEEDS CONSULT US . BOLT TIGHTENING TORQUES - # FOR DISC PACK BOLTS , ## FOR HUB BOLTS.

UNIQUE TRANSMISSION I PVT LTD

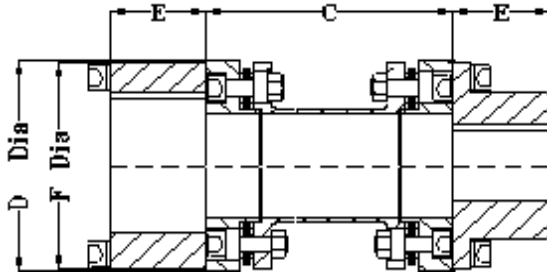

**Metaflex
Coupling
Series 80X SPL**

* meet API 610 requirements
 * can be supplied to API 671 on request

Size	Nominal HP/100 RPM	Rating Torque NM	Peak Torque NM	Max Speed RPM	Max Bore D1 MM	Max Bore D2 MM	D Dia MM	G Dia MM	F Dia MM	E, Hub Length MM	Std C MM
65	0.45	32	64	25000	28	42	66	42	63	28	100
80	0.9	64	128	25000	38	48	75	54	72	30	100
100	1.8	128	256	25000	42	55	87	60	83	32	100
125	2.6	185	370	20000	48	65	102	70	98	41	100
150	4	285	570	20000	48	70	105	69	102	45	100
162	7	500	1000	18000	55	75	115	80	111	48	140
180	9	640	1280	18000	65	90	130	90	125	55	140
200	12	855	1710	16000	70	95	143	100	138	54	140
220	15	1070	2140	16000	80	102	152	112	148	62	140
225	18	1282	2564	14600	75	100	150	110	145	67	140
250	25	1780	3560	12300	90	115	173	130	168	76	140
262	33	2350	4700	12300	90	115	173	130	168	76	140
300	56	3990	7980	11000	110	140	203	157	198	86	180
312	56	3990	7980	11000	110	140	203	157	198	86	180
350	70	4990	9980	10500	115	155	227	162	221	95	180
375	100	7125	14250	10000	130	170	252	187	246	102	200
425	140	9975	19950	8000	130	185	273	191	273	108	200
450	170	12110	24220	7000	145	200	293	211	293	114	250
500	270	19230	38460	6000	175	230	333	251	333	127	250
Size	Mass KG	Inertia MR ² KG.M ²	Maximum Misalignment		Tor. Stiff MNM/Rad	Axial Spring Rate N/MM	Bolt Tight Torque				
			AXIAL MM	RADIAL MM			# NM	## MM			
65	1.6	0.001	1	0.6	0.01	25	6	6			
80	2.3	0.002	1.2	0.6	0.02	30	10	6			
100	3.2	0.003	2	0.6	0.06	50	24	10			
125	5.0	0.008	2	0.8	0.06	60	24	24			
150	5.3	0.008	1.3	0.8	0.06	150	24	24			
162	7.2	0.013	1.3	1.2	0.18	100	24	24			
180	9.7	0.025	1.5	1.2	0.20	130	48	48			
200	12.2	0.037	1.8	1.2	0.20	165	48	48			
220	15.1	0.052	2.0	1.2	0.26	130	48	48			
225	15.7	0.051	1.4	1.2	0.26	275	48	48			
250	21.5	0.099	2.2	1.2	0.38	195	48	48			
262	21.5	0.099	1.5	1.2	0.44	350	48	48			
300	36.0	0.222	3.0	1.2	0.64	370	200	80			
312	32.2	0.203	1.9	1.2	0.64	415	80	80			
350	46.0	0.370	2.0	1.2	1.07	500	200	200			
375	61.0	0.580	2.3	1.5	1.38	540	200	200			
425	85.0	0.990	2.5	1.5	2.14	725	400	400			
450	106.0	1.420	2.8	1.7	2.36	755	400	400			
500	137.0	2.470	3.0	1.9	3.92	920	400	400			

These Couplings have captured Centre Member .This feature prevents spacer subassembly from flying off even in unlikely event of Disc as well as bolt failure.

Mass , Inertia,Stiffness are at max bore with standard spacer dimension C listed above. Other C dimension are available as required on request .Hub dimensions can be modified to suit special needs. Max angular misalignment 0.50 Deg /Pack .Misalignment limits are for speeds upto 3000 RPM. For higher Speeds consult us . Bolt Tightening Torques - # for Disc Pack Bolts , ## for Hub Bolts .

Unique Transmission (India) Pvt Ltd

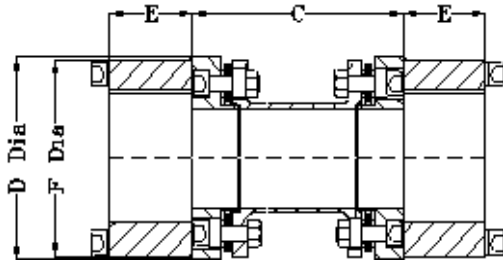

**METAFLEX
 COUPLING
 SERIES 80X - SP**

* meet API 610 requirements
 * can be supplied to API 671 on request

SIZE	NOMINAL HP/100 RPM	RATING TORQUE NM	PEAK TORQUE NM	MAX SPEED RPM	MAX BORE MM	E,HUB LENGTH MM	D DIA MM	F DIA MM	STD C MM
65	0.45	32	64	25000	42	28	66	63	100
80	0.9	64	128	25000	48	30	75	72	100
100	1.8	128	256	25000	55	32	87	83	100
125	2.6	185	370	20000	65	41	102	98	100
150	4	285	570	20000	70	45	105	102	100
162	7	500	1000	18000	75	48	115	111	140
180	9	640	1280	18000	90	55	130	125	140
200	12	855	1710	16000	95	54	143	138	140
220	15	1070	2140	16000	102	62	152	148	140
225	18	1282	2564	14600	100	67	150	145	140
250	25	1780	3560	12300	115	76	173	168	140
262	33	2350	4700	12300	115	76	173	168	140
300	56	3990	7980	11000	140	86	203	198	180
312	56	3990	7980	11000	140	86	203	198	180
350	70	4990	9980	10500	155	95	227	221	180
375	100	7125	14250	10000	170	102	252	246	200
425	140	9975	19950	8000	185	108	273	273	200
450	170	12110	24220	7000	200	114	293	293	250
500	270	19230	38460	6000	230	127	333	333	250
SIZE	MASS KG	INERTIA KG.M ²	MAX MISALIGNMENT		TORSIONAL STIFF MNM/RAD	AXIAL SPRING RATE N/MM	BOLT TORQUE		
			AXIAL MM	RADIAL MM			# NM	## MM	
65	2	0.001	1	0.6	0.01	25	6	6	
80	3	0.002	1.2	0.6	0.02	30	10	6	
100	4	0.004	2	0.6	0.06	50	24	10	
125	5	0.009	2	0.8	0.06	60	24	24	
150	6	0.01	1.3	0.8	0.06	150	24	24	
162	8.0	0.016	1.3	1.2	0.18	100	24	24	
180	11.0	0.030	1.5	1.2	0.20	130	48	48	
200	13.0	0.044	1.8	1.2	0.20	165	48	48	
220	17.0	0.062	2.0	1.2	0.26	130	48	48	
225	17.0	0.058	1.4	1.2	0.26	275	48	48	
250	23	0.115	2.2	1.2	0.38	195	48	48	
262	23	0.115	1.5	1.2	0.44	350	48	48	
300	38	0.25	3.0	1.2	0.64	370	200	80	
312	34	0.24	1.9	1.2	0.64	415	80	80	
350	51	0.44	2.0	1.2	1.07	500	200	200	
375	66	0.70	2.3	1.5	1.38	540	200	200	
425	95	1.22	2.5	1.5	2.14	725	400	400	
450	115	1.70	2.8	1.7	2.36	755	400	400	
500	152	3.00	3.0	1.9	3.92	920	400	400	

THESE COUPLINGS HAVE CAPTURED CENTRE MEMBER THIS FEATURE PREVENTS SPACER SUB ASSEMBLY FROM FLYING OFF EVEN IN UNLIKELY EVENT OF DISC AS WELL AS BOLT FAILURE .

MASS AND INERTIA , STIFFNESS ARE AT MAX BORE WITH STANDARD SPACER.DIMENSION C LISTED ABOVE.OTHER C DIMENSIONS ARE AVAILABLE AS REQUIRED ON REQUEST.HUB DIMENSIONS CAN BE MODIFIED TO SUIT SPECIAL NEEDS.MAX ANGULAR MISALIGNMENT 0.50 DEG/PACK.MISALIGNMENT LIMITS ARE FOR SPEEDS UPTO 3000 RPM.FOR HIGHER SPEEDS CONSULT US. BOLT TIGHTENING TORQUES - # FOR DISC PACK BOLTS , ## FOR HUB BOLTS.

UNIQUE TRANSMISSION I PVT LTD

**Metaflex
 Coupling
 Series 80 CC**

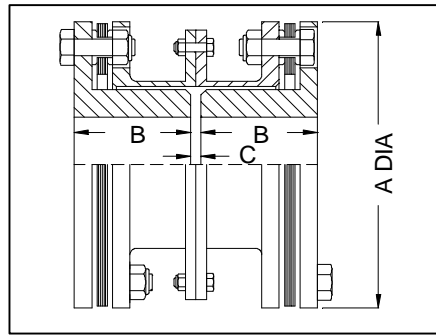

Size	Nominal HP/100 RPM	Rating Torque NM	Peak Torque NM	Max Speed RPM	Max Bore MM	B, Hub Length MM	A Dia MM	C MM
65	0.45	32	64	20000	15	40	63	3
80	0.9	64	128	20000	18	40	72	3
100	1.8	128	256	18650	20	42	83	3
125	2.6	185	370	15800	26	50	98	3
162	7	500	1000	13900	42	50	111	3
200	12	855	1710	11200	53	56	138	3
220	15	1070	2140	10450	60	60	148	3
225	18	1282	2564	10450	60	60	145	3
250	25	1780	3560	9200	70	66	168	5
262	33	2350	4700	9200	75	66	168	5
300	56	3990	7980	7800	75	72	198	5
312	56	3990	7980	7800	90	72	198	5
350	70	4990	9980	7000	90	83	221	6
375	100	7125	14250	6300	110	90	246	6
425	140	9975	19950	5800	115	101	267	6
450	170	12110	24220	5400	130	114	287	8
500	270	19230	38460	4700	145	120	327	8
550	400	28500	57000	4200	160	148	367	10
600	500	35625	71250	3800	185	153	406	10
700	800	57000	114000	3300	200	178	464	10
750	1100	78375	228000	3000	210	197	503	12
800	1600	114000	302000	3000	220	210	546	12

Size	Mass KG	Inertia MR ² KG.M ²	Maximum Misalignment		Torsional Stiff MNM/Rad	Axial Spring Rate N/MM	Bolt Tight Torque	
			AXIAL MM	RADIAL MM			#	##
							NM	MM
65	0.9	0.0004	1	0.6	0.01	25	6	6
80	1.2	0.0007	1.2	0.6	0.02	30	10	6
100	2.0	0.0013	2	0.6	0.06	50	24	6
125	3.0	0.004	2	0.8	0.06	60	24	10
162	4.0	0.007	1.3	0.8	0.18	100	24	10
200	7.6	0.018	1.8	0.8	0.20	165	48	24
220	9.4	0.026	2.0	0.8	0.26	130	48	24
225	9.8	0.027	1.4	0.8	0.26	275	48	24
250	13.7	0.048	2.2	0.9	0.38	195	48	24
262	13.7	0.049	1.5	0.9	0.44	350	48	24
300	22.0	0.10	3.0	1.2	0.64	370	200	24
312	21.0	0.11	1.9	1.2	0.64	415	80	24
350	30.0	0.19	2.0	1.2	1.07	500	200	48
375	41.0	0.31	2.3	1.5	1.38	540	200	80
425	54.0	0.50	2.5	1.5	2.14	725	400	80
450	64.0	0.69	2.8	1.7	2.36	755	400	200
500	92.0	1.24	3.0	1.9	3.92	920	400	200
550	126.0	2.19	3.2	2.1	5.64	920	540	200
600	167.0	3.45	3.7	2.1	6.93	900	700	400
700	259.0	7.15	4.1	2.4	11.3	1230	1400	540
750	321.0	10.25	4.6	2.4	15	1480	1800	700
800	428.0	16.12	5.0	2.6	ON REQ	ON REQ	2400	700

Mass , Inertia,Stiffness are at max bore with standard dimension C listed above. Other C Dimension C dimension are available as required on request .Hub dimensions can be modified to suit special needs. Max angular misalignment 0.50 Deg /Pack .Misalignment limits are for speeds upto 3000 RPM. For higher Speeds consult us . Bolt Tightening Torques - # for Disc Pack Bolts , ## for Hub Bolts .

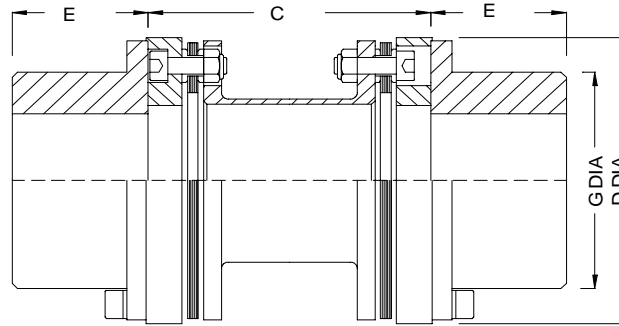

METAFLEX COUPLING 80 Q

SIZE	NOMINAL HP/100 RPM	RATING TORQUE NM	PEAK TORQUE NM	MAX SPEED RPM	MAX BORE MM	E,HUB LENGTH MM	D DIA MM	G DIA MM	STD C MM
250	37	2635	5270	16500	90	76	173	130	140
262	50	3560	7120	16500	90	76	173	130	140
300	84	5985	11970	11000	110	86	203	157	180
312	84	5985	11970	11000	110	86	203	157	180
350	120	8550	17100	10500	130	95	227	180	180
375	150	10685	21370	10000	130	102	252	187	200
425	210	14960	29920	8000	140	120	273	200	200
450	280	20000	40000	7000	160	130	293	230	250
500	400	28500	57000	6000	180	140	333	260	250
550	600	42750	85500	5360	200	160	373	270	300
600	800	57000	114000	4850	220	180	412	300	300
700	1200	85500	171000	4250	270	200	470	370	325
750	1600	114000	228000	3920	300	AS REQD	510	DO	325
800	2120	151000	302000	3570	330	AS REQD	560	DO	350
850	2735	195000	390000	3330	370	AS REQD	600	DO	550
900	3350	240000	480000	3075	400	AS REQD	650	DO	550

SIZE	MASS KG	INERTIA KG.M^2	MAX MISALIGNMENT		TORSIONAL STIFF MNM/RAD	AXIAL SPRING RATE N/MM	BOLT TORQUE	
			AXIAL MM	RADIAL MM			#	##
							NM	MM
250	20.0	0.082	2.2	1.2	0.38	195	80	48
262	20.0	0.082	1.5	1.2	0.44	350	80	48
300	34	0.19	3.0	1.2	0.64	370	200	80
312	30	0.17	1.9	1.2	0.64	415	80	80
350	42	0.30	2.0	1.2	1.07	500	200	80
375	55	0.47	2.3	1.5	1.38	540	200	200
425	75	0.77	2.5	1.5	2.14	725	400	200
450	97	1.15	2.8	1.7	2.36	755	400	200
500	122	1.95	3.0	1.9	3.92	920	400	400
550	155	3	3.2	2.1	5.64	920	540	400
600	ON REQ	ON REQ	3.7	2.1	6.93	1230	700	400
700	ON REQ	ON REQ	4.1	2.4	11.3	1480	1600	1400
750	ON REQ	ON REQ	4.6	2.4	ON REQ	ON REQ	2160	1600
800	ON REQ	ON REQ	10.0	2.5	ON REQ	ON REQ	2800	1600
850	ON REQ	ON REQ	10.0	3	ON REQ	ON REQ	4000	1600
900	ON REQ	ON REQ	10.0	3	ON REQ	ON REQ	6000	2160

MASS AND INERTIA ,STIFFNESS ARE AT MAX BORE WITH STANDARD SPACER.DIMENSION C LISTED ABOVE.OTHER C DIMENSIONS ARE AVAILABLE AS REQUIRED ON REQUEST.HUB DIMENSIONS CAN BE MODIFIED TO SUIT SPECIAL NEEDS.MAX ANGULAR MISALIGNMENT 0.50 DEG/PACK.MISALIGNMENT LIMITS ARE FOR SPEEDS UPTO 3000 RPM.FOR HIGHER SPEEDS CONSULT US. BOLT TIGHTENING TORQUES - # FOR DISC PACK BOLTS ,## FOR HUB BOLTS.

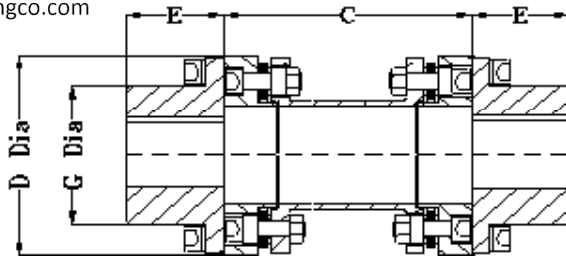

**Metaflex
 Coupling
 Series 80 QX**

* meet API 610 requirements
 * can be supplied to API 671 on request

Size	Nominal HP/100 RPM	Rating Torque NM	Peak Torque NM	Max Speed RPM	Max Bore MM	E, Hub Length MM	D Dia MM	G Dia MM	Std C MM
250	37	2635	5270	16500	90	76	173	130	140
262	50	3560	7120	16500	95	76	173	130	140
300	85	6050	12100	14000	110	86	203	157	180
312	85	6050	12100	14000	110	86	203	157	180
350	120	8550	17100	13000	130	95	227	180	180
375	150	10685	21370	11700	130	102	252	187	200
425	210	14960	29920	11000	140	120	273	191	200
450	280	20000	40000	10500	170	130	293	230	250
500	400	28500	57000	8860	180	140	333	260	250
550	600	42750	85500	7900	210	AS REQ	373	270	300
551	600	42750	85500	7900	200	AS REQ	356	270	300
600	800	57000	114000	7160	220	Do	412	As reqd	300
601	800	57000	114000	7160	210	Do	384	DO	300
700	1200	85500	171000	6280	270	Do	470	DO	325
750	1600	114000	228000	5780	300	Do	510	DO	325
800	2120	151000	302000	3570	330	Do	560	DO	350
850	2735	195000	390000	3330	370	Do	600	DO	550
900	3350	240000	480000	3075	400	Do	650	DO	550
Size	Mass KG	Inertia MR^2 KG.M^2	Maximum Misalignment		Torsional Stiff MNM/Rad	Axial Spring Rate N/MM	Bolt Tight Torque		
			AXIAL MM	RADIAL MM			# NM	## MM	
250	20.0	0.082	2.2	1.2	0.80	195	80	48	
262	20.0	0.082	1.5	1.2	1.10	350	80	48	
300	34.0	0.19	3.0	1.2	1.40	370	200	80	
312	30.0	0.17	1.9	1.2	1.50	415	80	80	
350	42.0	0.30	2.0	1.2	2.80	500	200	80	
375	55.0	0.47	2.3	1.5	3.70	540	200	200	
425	75.0	0.77	2.5	1.5	5.80	725	400	400	
450	97.0	1.15	2.8	1.7	6.60	755	400	400	
500	122.0	1.95	3.0	1.9	11.00	920	400	400	
550	155.0	3.00	3.2	2.1	16.90	920	540	400	
551	135.0	2.50	3.2	2.1	16.90	920	700	400	
600	On Req	On Req	3.7	2.1	19.00	1230	700	400	
601	On Req	On Req	3.7	2.1	19.00	1230	700	400	
700	Do	Do	4.1	2.4	39	1480	1400	1400	
750	Do	Do	4.6	2.4	On Req	On Req	2160	1600	
800	Do	Do	10.0	2.5	Do	Do	2800	1600	
850	Do	Do	10.0	3	Do	Do	On Req	On Req	
900	Do	Do	10.0	3	Do	Do	Do	Do	

THESE COUPLINGS HAVE CAPTURED CENTRE MEMBER THIS FEATURE PREVENTS SPACER SUB ASSEMBLY FROM FLYING OFF EVEN IN UNLIKELY EVENT OF DISC AS WELL AS BOLT FAILURE .

Mass , Inertia,Stiffness are at max bore with standard spacer dimension C listed above. Other C dimension are available as required on request .Hub dimensions can be modified to suit special needs. Max angular misalignment 0.50 Deg /Pack .Misalignment limits are for speeds upto 3000 RPM. For higher Speeds consult us . Bolt Tightening Torques - # for Disc Pack Bolts , ## for Hub Bolts .

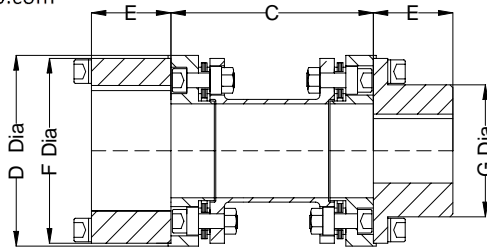

**Metaflex
 Coupling
 Series 80 QX-SPL**

* meet API 610 requirements
 * can be supplied to API 671 on request

Size	Nominal HP/100 RPM	Rating Torque NM	Peak Torque NM	Max Speed RPM	Max Bore Std MM	Max Bore Large mm	E, Hub Length MM	D Dia MM	G Dia MM	Std C MM
250	37	2635	5270	15300	90	115	76	173	130	140
262	50	3560	7120	15300	95	115	76	173	130	140
300	85	6050	12100	14000	110	140	86	203	157	180
312	85	6050	12100	14000	110	140	86	203	157	180
350	120	8550	17100	13000	130	155	95	227	180	180
375	150	10685	21370	11700	130	170	102	252	187	200
425	210	14960	29920	10800	140	185	108	273	191	200
450	260	18500	37000	10000	160	200	114	293	211	250
500	400	28500	57000	8860	180	230	127	333	251	250
Size	Mass KG	Inertia MR^2 KG.M^2	Maximum Misalignment		Torsional Stiff MNM/Rad	Axial Spring Rate N/MM	Bolt Tight Torque			
			AXIAL MM	RADIAL MM			# NM	## MM		
250	22.0	0.1	2.2	1.2	0.80	220	80	48		
262	22.0	0.1	1.5	1.2	1.10	350	80	48		
300	36.0	0.22	3.0	1.2	1.40	370	200	80		
312	32.2	0.20	1.9	1.2	1.50	415	80	80		
350	46.0	0.37	2.0	1.2	2.80	500	200	80		
375	61.0	0.58	2.3	1.5	3.70	540	200	200		
425	85.0	0.99	2.5	1.5		725	400	400		
450	106.0	1.42	2.8	1.7		755	400	400		
425	137.0	2.47	3.0	1.9	5.80	920	400	400		

THESE COUPLINGS HAVE CAPTURED CENTRE MEMBER THIS FEATURE PREVENTS SPACER SUB ASSEMBLY FROM FLYING OFF EVEN IN UNLIKELY EVENT OF DISC AS WELL AS BOLT FAILURE .

Mass , Inertia,Stiffness are at max bore with standard spacer dimension C listed above. Other

C dimension are available as required on request .Hub dimensions can be modified to suit special needs.

Max angular misalignment 0.50 Deg /Pack .Misalignment limits are for speeds upto 3000 RPM. For higher

Speeds consult us . Bolt Tightening Torques - # for Disc Pack Bolts , ## for Hub Bolts .

Unique Transmission (India) Pvt Ltd

10/ID Lal Bazar Street ,Calcutta 700001

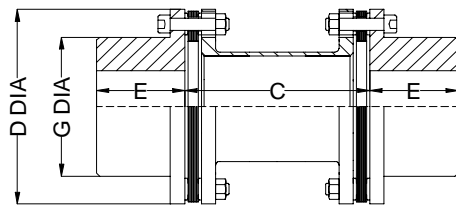

**METAFLEX
COUPLING
SERIES 80 L**

SIZE	NOMINAL HP/100 RPM	RATING TORQUE NM	PEAK TORQUE NM	MAX SPEED RPM	MAX BORE MM	E, HUB LENGTH MM	D DIA MM	G DIA MM	STD C MM
65	0.45	32	64	20000	24	28	63	34	100
80	0.9	64	128	20000	28	30	72	40	100
100	1.8	128	256	18650	32	32	83	46	100
125	2.6	185	370	15800	42	41	98	59	100
150	4	285	570	15800	42	45	102	62	100
162	7	500	1000	13900	48	48	111	71	140
180	9	640	1280	12500	55	55	125	78	140
200	12	855	1710	11200	55	54	138	84	140
220	15	1070	2140	10450	65	62	148	93	140
225	18	1282	2564	10450	65	67	145	95	140
250	25	1780	3560	9200	80	76	168	114	140
262	33	2350	4700	9200	80	76	168	114	140
300	56	3990	7980	7800	90	86	198	128	140
312	56	3990	7980	7800	100	86	198	140	140
350	70	4990	9980	7000	105	95	221	150	140
375	100	7125	14250	6300	115	102	246	170	180
425	140	9975	19950	5800	120	108	267	178	180
450	170	12110	24220	5400	135	114	287	194	200
500	270	19230	38460	4700	155	127	327	226	225
550	400	28500	57000	4200	180	148	367	256	250
600	500	35625	71250	3800	190	153	405	276	250
700	800	57000	114000	3300	220	178	464	318	275
750	1100	78375	228000	3000	220	191	503	321	275
800	1600	114000	302000	3000	240	210	546	349	300
SIZE	MASS KG	INERTIA KG.M^2	MAX MISALIGNMENT		TOR STIFF MNM/RAD	AXIAL SPRING RATE N/MM	BOLT TORQUE #		
			AXIAL MM	RADIAL MM			#		
							NM		
65	0.9	0.0004	1	0.6	0.01	25	6		
80	1.2	0.0007	1.2	0.6	0.02	30	10		
100	2.0	0.0013	2.0	0.6	0.06	50	24		
125	3.0	0.0040	2.0	0.8	0.06	60	24		
150	3.6	0.0047	1.3	0.8	0.06	150	24		
162	4.7	0.007	1.3	1.2	0.18	100	24		
180	6.2	0.012	1.5	1.2	0.20	130	48		
200	7.6	0.018	1.8	1.2	0.20	165	48		
220	9.4	0.026	2.0	1.2	0.26	130	48		
225	9.8	0.027	1.4	1.2	0.26	275	48		
250	13.7	0.048	2.2	1.2	0.38	195	48		
262	13.7	0.049	1.5	1.2	0.44	350	48		
300	22	0.10	3.0	1.2	0.64	370	200		
312	21	0.11	1.9	1.2	0.64	415	80		
350	30	0.19	2.0	1.2	1.07	500	200		
375	41	0.31	2.3	1.5	1.38	540	200		
425	54	0.50	2.5	1.5	2.14	725	400		
450	64	0.69	2.8	1.7	2.36	755	400		
500	92	1.24	3.0	1.9	3.92	920	400		
550	126	2.19	3.2	2.1	5.64	920	540		
600	167	3.45	3.7	2.1	6.93	900	700		
700	259	7.15	4.1	2.4	11.3	1230	1400		
750	321	10.25	4.6	2.4	15	1480	1800		
800	428	16.12	5.0	2.6	ON REQ	ON REQ	2400		

Mass and inertia ,stiffness are at max bore with standard spacer .dimension C listed above.other C dimensions are available as required on request.hub dimensions can be modified to suit special needs. Max angular misalignment 0.50 deg/pack. misalignment limits are for speeds upto 3000 rpm.for higher speeds consult us. Bolt tightening torques - # for disc pack bolts ,## for hub bolts.

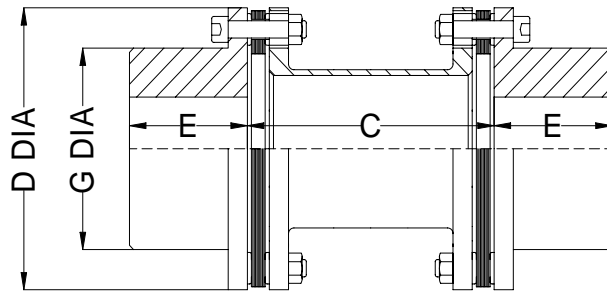

**Metaflex
Coupling
Series 80LQ**

SIZE	NOMINAL HP/100 RPM	RATING TORQUE NM	PEAK TORQUE NM	MAX SPEED RPM	MAX BORE MM	E,HUB LENGTH MM	D DIA MM	G DIA MM	STD C MM
300	85	6050	12100	11000	90	86	198	128	140
312	85	6050	12100	11000	100	86	198	140	140
350	120	8550	17100	10500	110	95	221	150	140
375	150	10685	21370	10000	120	102	246	170	180
425	210	14960	29920	8000	125	108	267	178	180
450	260	18500	37000	7000	140	114	287	197	200
500	400	28500	57000	6000	155	127	327	220	225
550	600	42750	85500	5360	175	148	367	250	250
551	600	42750	85500	5360	170	148	350	240	250
600	800	57000	114000	4850	195	190	406	276	250
601	800	57000	114000	4850	190	190	380	260	250
700	1200	85500	171000	4250	220	220	464	318	275
750	1600	114000	228000	3920	220	220	510	321	275
800	2120	151000	302000	3570	250	250	560	360	300
850	2735	195000	390000	3330	280	280	600	380	350
900	3350	240000	480000	3075	300	300	650	420	350

SIZE	MASS KG	INERTIA KG.M^2	MAX MISALIGNMENT		TORSIONAL STIFF MNM/RAD	AXIAL SPRING RATE N/MM	BOLT TORQUE # NM
			AXIAL MM	RADIAL MM			
300	23	0.10	3.0	1.2	1.48	370	200
312	22	0.11	1.9	1.2	1.86	415	80
350	32	0.19	2.0	1.2	2.68	500	200
375	43	0.31	2.3	1.5	3.37	540	200
425	57	0.50	2.5	1.5	6.00	725	400
450	68	0.69	2.8	1.7	7.00	755	400
500	100	1.24	3.0	1.9	11.20	920	400
550	130	2.2	3.2	2.1	17.20	920	540
551	117	1.8	3.2	2.1	17.20	920	700
600	ON REQ	ON REQ	3.7	2.1	20.0	1230	700
601	ON REQ	ON REQ	3.7	2.1	20.0	1230	700
700	ON REQ	ON REQ	4.1	2.4	40.0	1480	1600
750	ON REQ	ON REQ	4.6	2.4	ON REQ	ON REQ	2160
800	ON REQ	ON REQ	10.0	2.5	ON REQ	ON REQ	2800
850	ON REQ	ON REQ	10.0	3	ON REQ	ON REQ	4000
900	ON REQ	ON REQ	10.0	3	ON REQ	ON REQ	6000

Mass and inertia ,stiffness are at max bore with standard spacer .dimension C listed above.other C dimensions are available as required on request.hub dimensions can be modified to suit special needs. Max angular misalignment 0.50 deg/pack. misalignment limits are for speeds upto 3000 rpm.for higher speeds consult us. Bolt tightening torques - # for disc pack bolts ,## for hub bolts.

Unique Transmission (India) Pvt Ltd
10/ID Lal Bazar Street ,Kolkata 700001, India



Metaflex All Metal Dry Flexible Laminated Disc(Membrane/ Diaphragm) Couplings

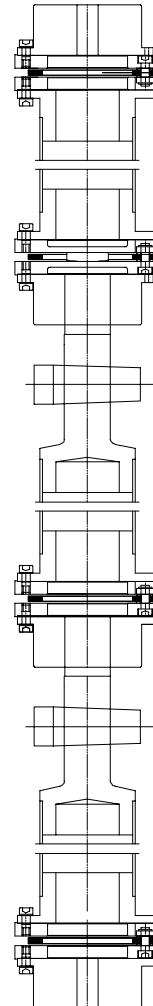
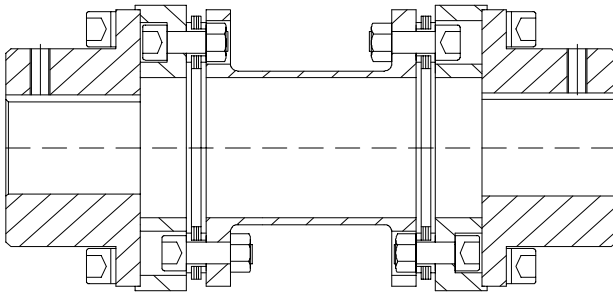

- *** Couplings specially designed for Petrochemical Industry meeting API 610 requirements. Can be supplied to meet API 671 requirements.
- *** These are High Performance Couplings of all metal Construction for high speed as well as slow speed applications.
- *** Couplings require no lubrication. Require very little maintenance.
- *** Highly popular for Turbine/Pump/Fan/Compressor/Paper Mill/Sugar Mill Drives
- *** Supplied for Powers upto 12000 KW for both high speed & slow speed.

- *** Metaflex Floating shafts are available in single span - multispans.
Lengths upto 20 metres in service for vertical Pumps. Ideally suitable for Vertical Pump Drives
Also available with adjustable lengths - with Shrink Disc / Spline arrangement

- *** Torsional Vibration Analysis on request

Unique Transmission (India) Pvt Ltd.

Head Office

10/ID Lal Bazar Street ,Calcutta 700001



*****Metaflex** Flexible Laminated Disc (Diaphragm/Membrane) Couplings are latest generation Couplings. Disc Packs of Series 80 range are unitized and are specially shaped to give flexibility & pure tensile loads for transmission of torque.

***The Unitised design of disc packs permits easy assembly/disassembly without having to deal with large number of separate discs and washers.

***The couplings can be supplied to meet API 610 /API 671 requirements. Various special designs are available to suit varied needs.

Series 80 – This is the basic standard design. The central spacer is drop down type. Whole spacer assembly is spigotted on the end hubs to ensure concentricity and excellent dynamic balance. For a given OD the hubs have comparatively large bore capacity resulting in selection of coupling which is compact and has high Power/Weight ratio .Spacer Assembly/disc packs can be replaced without having to shift either driving or driven equipment.

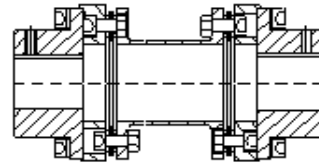

Series 80SPL– This is a simple variation of basic Series 80 design with large hub at one end. This is especially suitable for Motor driven pumps where Motor shaft dia is much larger than pump shaft dia. Coupling OD/Weight/ Inertia and costs are minimum in this style for a given drive.

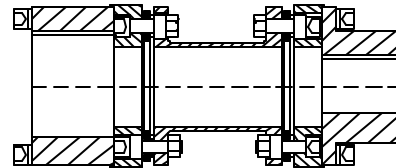

Series 80SP– This style is also a simple variation of Series 80 with large hub at both ends and is suitable for applications where both driving and driven shaft diameters are comparatively large.

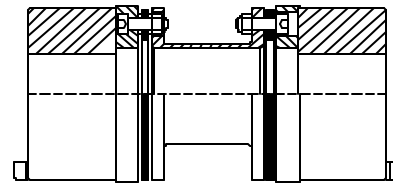

Series 80L – this Design is suitable when driving and driven shaft dia are considerably smaller than max bore capacity of Series 80 standard coupling. For such cases this design gives light- weight and inertia. The design can be supplied with comparatively small spacer length. Permissible maximum speed is somewhat lower than standard series 80 coupling – but adequate for most applications.

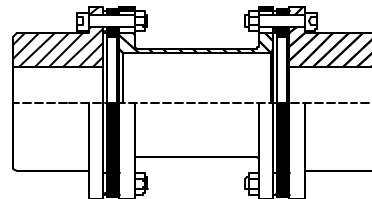

Series 80 CC- The design permits very small distance between shaft ends. The design is ideal for applications where non-spacer Gear couplings are to be replaced by Metaflex Couplings.This design has twin disc packs permitting misalignment in all directions.Either driving or driven equipment is to be shifted for removal of disc packs.

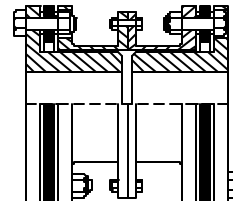

Series 80 CCS – This is also a close coupled design. The spacer is of split design.Split spacer permits removal/fitment of disc packs without having to shift connected equipment. This design has also twin disc packs permitting misalignment in all directions.

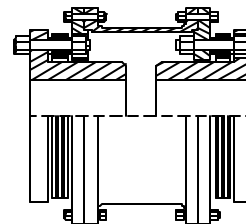

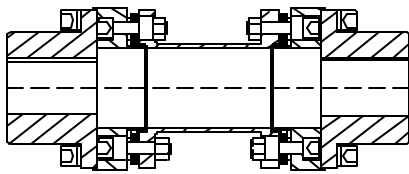

Series 80 X with captured center member. This feature prevents the spacer subassembly to fly away in unlikely event of failure of discs or bolts. Series 80X-SPL & 80X-SP are simple variations of series 80X permitting larger bore capacity.

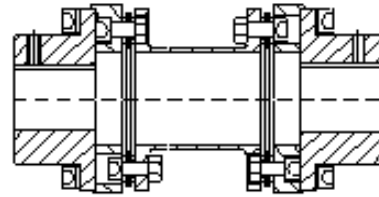

Series 80Q – is high Torque design . Overall Coupling size is most compact in this design. Weight & Inertia are minimum.

Series 80Q-SPL , 80QX , 80QX-SPL, 80LQ are simple variations of series 80Q. 80QSPL permits larger bore capacity. 80QX has captured spacer safety feature. 80QX-SPL has captured spacer safety feature & also larger bore capacity. Series 80LQ is suitable for applications where shaft dia are considerably smaller than the capacity of series 80Q.

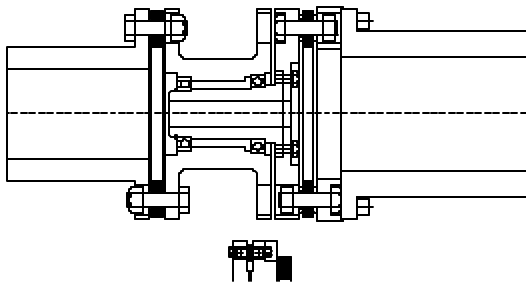

Metaflex coupling with shear pin – overload protection & double bearings. Unique design saves expensive equipment. During overload shearpins fail & driven side coasts to stop. Shear pins easily replaceable

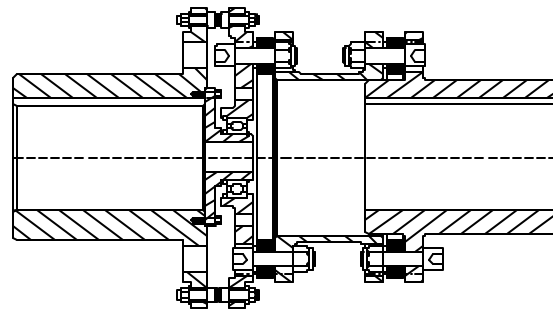

Metaflex coupling with shear pin – overload protection & single bearings. This is an alternative design .

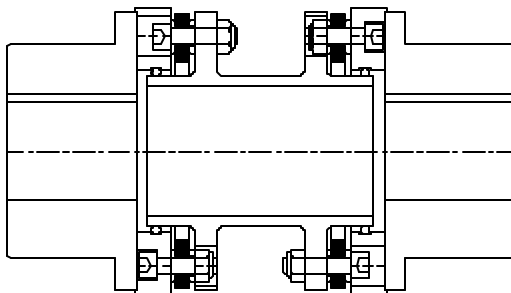

Metaflex Coupling with captured spacer – special design. Can replace similar imported coupling- with same overall dimensions & capacity.

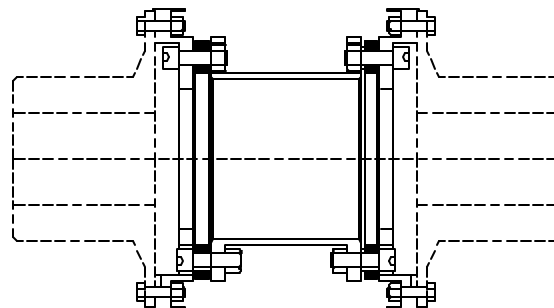

Metaflex Coupling – special design . low weight – large bore capacity. Spacer assemblies can be supplied to replace existing imported spacer of similar imported couplings.

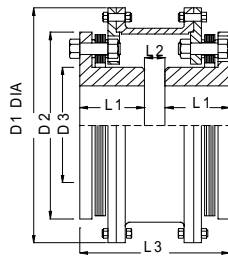

**Metaflex
 Coupling
 Series 80 CCS**

Disc Pack replaceable In Situ

Size	Nominal HP/100 RPM	Rating Torque NM	Peak Torque NM	Max Speed RPM	Max Bore MM	L1 Hub Length MM	D1 Dia MM	D2 Dia MM	D3 Dia MM	L1 MM	L2 MM	L3 MM
100	1.8	128	256	7600	20	32	120	83	28	32	10	74
125	2.6	185	370	7000	28	41	135	98	38	41	12	93
162	7	500	1000	6200	45	48	152	111	62	48	13	109
200	12	855	1710	5300	55	54	180	138	75	54	14	122
220	15	1070	2140	5000	60	62	190	148	84	62	14	138
225	18	1282	2564	5000	60	67	190	145	89	67	15	149
250	25	1780	3560	4400	70	76	219	168	100	76	16	168
262	33	2350	4700	4400	75	76	219	168	106	76	16	168
300	56	3990	7980	3800	75	86	254	201	106	86	16	188
312	56	3990	7980	3800	90	86	254	201	128	86	16	188
350	70	4990	9980	3400	90	95	280	221	128	95	18	208
375	100	7125	14250	3000	110	102	320	246	154	102	18	222
425	140	9975	19950	2800	115	108	340	267	165	108	22	238
450	170	12110	24220	2600	125	114	365	287	176	114	22	250
500	270	19230	38460	2200	140	127	428	323	200	127	25	279
550	400	28500	57000	2000	160	148	465	367	228	148	32	328
600	500	35625	71250	1800	180	153	520	406	255	153	32	338
700	800	57000	114000	1600	210	178	560	464	290	178	36	392

Size	Mass KG	Inertia MR ² KG.M ²	Maximum Misalignment		Torsional Stiff MNM/Rad	Axial Spring Rate N/MM	Bolt Tight Torque	
			AXIAL MM	RADIAL MM			#	##
							NM	MM
100	3.0	0.004	2	0.6	0.06	50	24	10
125	4.7	0.009	2	0.8	0.06	60	24	10
162	5.5	0.014	1.3	0.8	0.18	100	24	10
200	9.5	0.036	1.8	0.8	0.20	165	48	24
220	11.0	0.053	2.0	0.8	0.26	130	48	24
225	11.0	0.053	1.4	0.8	0.26	275	48	24
250	19.0	0.1	2.2	0.9	0.38	195	48	24
262	20.0	0.1	1.5	0.9	0.44	350	48	24
300	32.0	0.19	3.0	1.2	0.64	370	200	24
312	29.0	0.21	1.9	1.2	0.64	415	80	24
350	46.0	0.35	2.0	1.2	1.07	500	200	48
375	58.0	0.70	2.3	1.5	1.38	540	200	48
425	75.0	1.00	2.5	1.5	2.14	725	400	80
450	90.0	1.40	2.8	1.7	2.36	755	400	80
500	130.0	2.90	3.0	1.9	3.92	920	400	80
550	185.0	4.80	3.2	2.1	5.64	920	540	200
600	230.0	7.80	3.7	2.1	6.93	900	700	200
700	278.0	10.50	4.1	2.4	11.3	1230	1400	200

Mass , Inertia,Stiffness are at max bore with standard dimension listed above. Other Dimension are available as required on request .Hub dimensions can be modified to suit special needs.
 Max angular misalignment 0.50 Deg /Pack .Misalignment limits are for speeds upto 3000 RPM. For higher Speeds consult us . Bolt Tightening Torques - # for Disc Pack Bolts , ## for Hub Bolts .

Unique Transmission (India) Pvt Ltd
 10/ID Lal Bazar Street ,Calcutta 700001

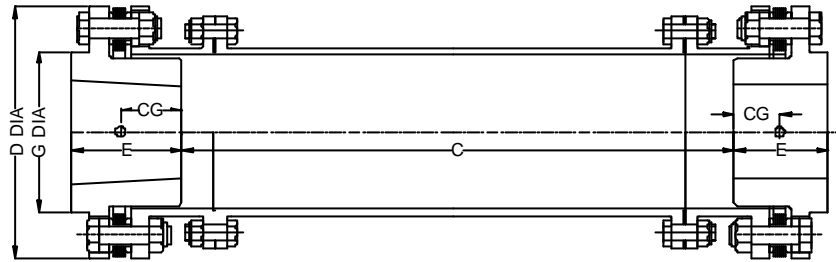

METAFLEX COUPLING SERIES 80RM

- ** Coupling in reduced moment design with lower moments on connected equipment
- ** Disc Packs & Bolts same as used in Metaflex Series 80Q
- ** Spacer is captured style
- ** High Torque , Low weight
- ** Meets API 671 requirements.
- ** Spacer is three piece with length adjustment feature
- ** Particularly useful when driving and/or driven shaft are with taper
- ** Suitable for High Speed Turbine Driven
- ** Smaller spacer Length available on request

SIZE	NOMINAL HP/100 RPM	RATING TORQUE NM	PEAK TORQUE NM	MAX SPEED RPM	MAX BORE HYD MM	MAX BORE KEYED MM	E,HUB LENGTH MM	D DIA MM	G DIA MM	Std C MM
250	37	2635	5270	22500	70	67	70	173	100	460
262	50	3560	7120	22500	75	70	80	173	108	460
300	84	5985	11970	19100	75	70	80	203	108	460
312	84	5985	11970	19100	90	90	95	203	131	460
350	95	6770	13540	17200	90	90	95	227	131	460
375	150	10685	21370	15600	110	105	115	252	158	460
425	210	14960	29920	14300	115	110	120	273	168	460
450	260	18500	37000	13300	120	120	125	293	176	460
500	400	28500	57000	11600	140	140	145	333	205	460
550	600	42750	85500	10300	155	155	160	373	228	460
600	800	57000	114000	9300	170	170	175	412	255	460
700	1200	85500	171000	8200	205	205	210	470	290	460
750	1600	114000	228000	7500	210	210	215	510	304	460
SIZE	MASS KG	INERTIA KG.M^2	MAX MISALIGNMENT		TORSIONAL STIFF MN/M/RAD	AXIAL SPRING RATE N/MM	BOLT TORQUE NM	CG MM		
			AXIAL MM	RADIAL MM						
250	19	0.062	2.2	1.2	0.35	195	48	40		
262	20	0.066	1.5	1.2	0.4	350	48	50		
300	36	0.17	3.0	1.2	0.56	370	200	43		
312	33	0.15	1.9	1.2	0.56	415	80	61		
350	45	0.28	2.0	1.2	0.92	500	200	55		
375	54	0.38	2.3	1.5	1.12	540	200	74		
425	63	0.59	2.5	1.5	1.65	725	400	68		
450	85	0.86	2.8	1.7	1.9	755	400	74		
500	122	1.4	3.0	1.9	3.2	920	400	93		
550	173	2.8	3.2	2.1	4.5	920	540	102		
600	235	4.6	3.7	2.4	5.7	900	700	111		
700	345	8.6	4.1	2.4	8.5	1230	1400	135		
750	415	12.7	4.6	2.6	11.1	1480	1800	131		

MASS AND INERTIA ,STIFFNESS ARE AT MAX BORE WITH STANDARD SPACER.DIMENSION C LISTED ABOVE.OTHER C DIMENSIONS ARE AVAILABLE AS REQUIRED ON REQUEST.HUB DIMENSIONS CAN BE MODIFIED TO SUIT SPECIAL NEEDS.MAX ANGULAR MISALIGNMENT 0.25 DEG/PACK.

UNIQUE TRANSMISSION I PVT LTD

10/ID LAL BAZAR STREET ,CALCUTTA 700001

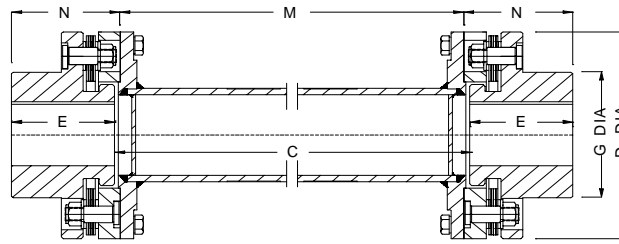

Unique Flexilink Coupling Type 11

SIZE	NOMINAL RATING HP/100 RPM	TORQUE NM	PEAK OVERLOAD TORQUE NM	MAX SPEED RPM	MAX BORE MM	D Dia MM	G Dia MM	E MM	N MM	M MIN MM	C MM
251	35.1	2500	6250	5600	75	230	125	110	115	140	150
321	44.9	3200	8000	5200	85	245	140	110	115	160	170
401	56.1	4000	10000	4800	95	270	155	125	132	170	184
501	70.2	5000	18000	4400	105	300	165	130	138	180	196
631	88.4	6300	22500	4000	120	325	185	130	138	190	206
801	112	8000	28000	3700	130	350	210	145	153	200	216
1000	140	10000	20000	3400	140	370	215	145	154	210	228
1001	154	11000	34900	3400	140	370	225	155	164	210	228
1251	175	12500	43000	3200	150	395	230	170	179	225	243
1601	225	16000	54500	2900	160	415	255	190	199	240	258
2000	281	20000	40000	2700	180	450	260	175	184	254	272
2001	281	20000	68000	2700	180	450	260	195	204	254	272
2501	351	25000	84000	2500	190	470	280	220	227	268	282
3201	449	32000	106000	2300	200	500	305	255	265	280	300
4000	561	40000	80000	2100	210	550	310	210	220	300	320
4001	561	40000	131500	2100	210	550	340	275	285	300	320
5000	702	50000	100000	1950	230	590	332	230	240	310	330
5001	702	50000	160000	1950	230	590	370	305	315	310	330
6301	884	63000	205000	1800	260	650	420	310	325	330	360
8000	1123	80000	160000	1650	270	690	375	270	285	360	390
8001	1123	80000	254000	1650	280	750	450	360	375	360	390

SIZE	MAX MISALIGNMENT		TOR STIFF	AXIAL STIFF	ANG STIFF (H CPLG)	MASS INERTIA		CHANGE/METRE SPACER LENGTH	
	AXIAL MM	RADIAL MM	MNM/RAD	N/MM	NM/RAD	KG	KGM2	MASS KG	MR2 KGM2
251	2.0	3.0	0.80	560	3250	44	0.267	18.1	0.04
321	2.0	3.0	0.98	450	3000	51	0.371	19.6	0.05
401	3.0	4.0	1.21	350	3000	72	0.596	23.4	0.08
501	4.0	4.0	1.55	560	11700	92	0.967	39.5	0.16
631	5.0	5.0	1.95	500	12380	115	1.463	32.0	0.14
801	6.0	5.0	2.65	635	18100	142	2.101	35.1	0.18
1000	6.0	5.0	2.57	350	11350	147	2.13	34.5	0.22
1001	6.0	5.0	3.00	560	18100	178	2.807	39.0	0.25
1251	6.0	6.0	3.75	750	28300	211	3.914	51.3	0.35
1601	6.0	6.0	4.12	600	25400	235	5.222	72.0	0.97
2000	8.0	6.5	4.75	580	27500	259	4.478	51.6	0.565
2001	8.0	6.5	5.45	820	38500	310	7.873	64.1	0.68
2501	8.0	7.0	6.70	945	51500	359	9.731	71.9	0.76
3201	8.0	7.0	8.75	1160	73000	441	13.6	80.8	1.07
4000	8.0	7.5	8.75	490	37000	481	12.5	88.7	1.42
4001	8.0	7.5	10.60	900	68000	620	22.1	101	1.68
5000	8.0	8.0	11.20	550	49000	625	17.0	100	2.02
5001	8.0	8.0	13.60	945	84000	757	30.9	100	2.02
6301	10.5	8.5	17.50	945	103000	975	48.6	132	3.11
8000	10.0	9.0	18.50	620	77000	911	35.0	124	3.88
8001	10.0	10.0	21.80	975	124000	1207	66.2	151	4.66

A- Mass & Inertia , Torsional Stiffness are with minimum spacer 'M'

B- Longer Spacer Lengths available as required

Unique Transmission (India) Pvt. Ltd.

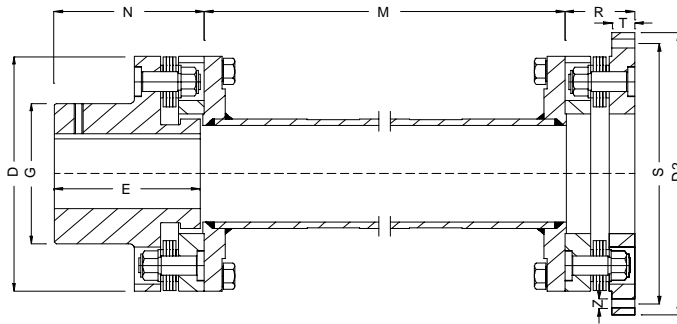

Unique Flexilink Coupling Type 13

SIZE	FINAL RATING HP/100 RPM	TORQUE NM	PEAK OVERLOAD TORQUE NM	MAX SPEED RPM	MAX BORE MM	D Dia MM	G Dia MM	E MM	N MM	M MIN MM	O MM	R MM
251	35.1	2500	6250	5600	75	230	125	110	115	140	105	56.5
321	44.9	3200	8000	5200	85	245	140	110	115	160	115	58.5
401	56.1	4000	10000	4800	95	270	155	125	132	170	135	62.5
501	70.2	5000	18000	4400	105	300	165	130	138	180	150	73.5
631	88.4	6300	22500	4000	120	325	185	130	138	190	160	81.5
801	112	8000	28000	3700	130	350	210	145	153	200	180	85.5
1000	140	10000	20000	3400	140	370	215	145	154	210	190	79.5
1001	154	11000	34900	3400	140	370	225	155	164	210	190	89.5
1251	175	12500	43000	3200	150	395	230	170	179	225	200	100.5
1601	225	16000	54500	2900	160	415	255	190	199	240	220	100.5
2000	281	20000	40000	2700	180	450	260	175	184	254	230	93.5
2001	281	20000	68000	2700	180	450	260	195	204	254	230	117.5
2501	351	25000	84000	2500	190	470	280	220	227	268	240	119.5
3201	449	32000	106000	2300	200	500	305	255	265	280	260	127.5
4000	561	40000	80000	2100	210	550	310	210	220	300	290	115.5
4001	561	40000	131500	2100	210	550	340	275	285	300	290	137.5
5000	702	50000	100000	1950	230	590	332	230	240	310	320	125.5
5001	702	50000	160000	1950	230	590	370	305	315	310	320	141.5
6301	884	63000	205000	1800	260	650	420	310	325	330	360	151.5
8000	1123	80000	160000	1650	270	690	375	270	285	360	400	141.5
8001	1123	80000	254000	1650	280	750	450	360	375	360	400	159.5

SIZE	D2 Dia MM	Z NO*MM	S Dia MM	T MM	MAX MISALGNMENT		TOR STIFF MNM/RAD	AXIAL STIFF N/MM	ANG STIFF (H CPLG) NM/RAD	MASS KG	INE-RTIA KGM2	CHANGE/METRE SPACER LENGTH	
					AXIAL MM	RADIAL MM						MASS KG	MR2 KGM2
251	300	8*18	265	18	2.0	3.0	0.80	560	3250	42	0.33	18.1	0.04
321	315	8*18	280	19	2.0	3.0	0.98	450	3000	49	0.44	19.6	0.05
401	340	12*18	305	21	3.0	4.0	1.21	350	3000	67	0.69	23.4	0.08
501	365	12*18	330	23	4.0	4.0	1.55	560	11700	87	1.09	39.5	0.16
631	390	12*18	360	26	5.0	5.0	1.95	500	12380	109	1.64	32.0	0.14
801	430	12*22	395	27	6.0	5.0	2.65	635	18100	132	2.37	35.1	0.18
1000	450	12*22	410	24	6.0	5.0	2.57	350	11350	139	2.18	34.5	0.22
1001	450	12*22	410	29	6.0	5.0	3.00	560	18100	166	3.13	39.0	0.25
1251	470	12*22	435	33	6.0	6.0	3.75	750	28300	198	4.33	51.3	0.35
1601	495	12*26	455	33	6.0	6.0	4.12	600	25400	217	5.62	72.0	0.97
2000	530	12*26	490	28	8.0	6.5	4.75	580	27500	239	4.78	51.6	0.57
2001	530	12*26	490	40	8.0	6.5	5.45	820	38500	289	8.64	64.1	0.68
2501	565	12*26	520	39	8.0	7.0	6.70	945	51500	335	10.8	71.9	0.76
3201	595	12*26	550	40	8.0	7.0	8.75	1160	73000	408	14.5	80.8	1.07
4000	665	12*33	610	35	8.0	7.5	8.75	490	37000	454	13.2	88.7	1.42
4001	665	12*33	610	46	8.0	7.5	10.6	900	68000	556	24.0	101	1.68
5000	705	12*33	650	38	8.0	8.0	11.2	550	49000	559	18.5	100	2.02
5001	705	12*33	650	46	8.0	8.0	13.6	945	84000	661	32.5	100	2.02
6301	770	12*33	710	49	10.5	8.5	17.5	945	103000	841	50.2	132	3.11
8000	810	12*39	750	42	10.0	9.0	18.5	620	77000	795	36.9	124	3.88
8001	810	12*39	750	52	10.0	10.0	21.8	975	124000	1012	66.6	151	4.66

A- Mass & Inertia , Torsional Stiffness are with minimum spacer 'M'

B- Longer Spacer Lengths available as required

Unique Transmission (India) Pvt. Ltd.

10/ID LAL BAZAR STREET ,CALCUTTA 700001

TEL NO - 91-33-2200366,2480433,2480231

FAX -91-33-2206593

Metaflex Floating Shafts Type SN , SF , SV and SVA

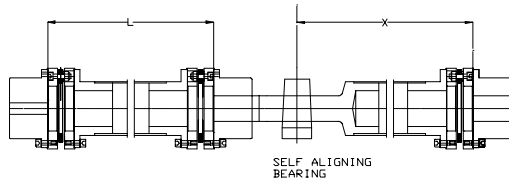

Metaflex Flexible shafts are ideally suitable for connecting machines relatively far apart . Typical uses are Paper Machinery Drive , Vertical Pump Drive.

Shafts are available in fixed Length as well as adjustable Lengths with Shrink Disc/ Splines. Hollow tubes are used to fabricate shafts. Shafts are ligh weight and require very little maintenance. Lubrication is required only for intermediate bearings.

Tube Size is selected to ensure operation well away from critical whirling speed.

$$N_{cr} = 1.16 \cdot 10^5 \cdot (D_o^2 + D_i^2)^{0.5} / L^2 \text{ RPM}$$

Where D_o is Tube OD in metre , D_i is Tube ID in metre , L is span in metre.

For semifloating shaft type SF , span is bearing centre to cr of disc pack

For Floating Shaft Type SN , SV , SVA , span is centre of Disc pack to Cr of disc pack

Tube OD mm	Max Span in mm L for SF,SV, SVA X for Type SF			Tube per metre		Shaft Size Type SN/SF/SV/SVA
	1500 RPM	1000 RPM	750 RPM	Weight Kg	MR ² Kg.m ²	
33.4	1570	1930	2230	2	0.001	65
44.5	1830	2240	2590	3	0.001	65,80
50.8	1960	2560	2780	3.5	0.002	80,100
57.2	2090	2700	2960	3.9	0.003	100
63.5	2200	2830	3110	4.8	0.004	125,150
69.8	2300	2970	3270	5.3	0.006	162,180,200
76.2	2420	3210	3430	5.8	0.008	162,180,200
88.9	2620	3440	3710	6.9	0.012	200,220,225,250
101.6	2810	3640	3970	8.8	0.022	250,262,300,312
114.3	2970	3840	4200	13	0.039	250,262,300,312
127	3140	4060	4440	14.5	0.055	300,312,350
141.3	3320	4410	4690	16.2	0.075	300,312,350,375
168.3	3600	5000	5000	28.2	0.18	375,425,450
219.1	4120	5000	5000	on req	on req	500,550,600
273.1	4610	5000	5000	on req	on req	550,600,700,750

The above is rough indicative- for information only.

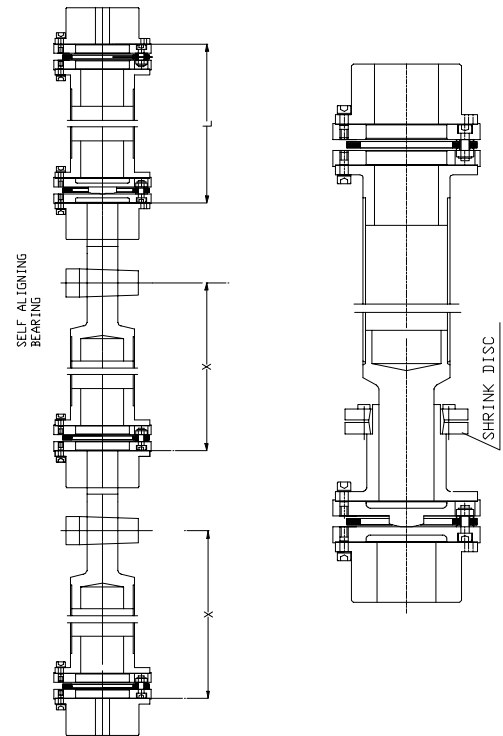

**Type SVA - Adjustable
With Shrink Discs
Length adjustment in
Stationary Condition only**

Metaflex Floating Shaft Couplings

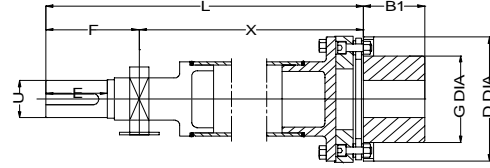
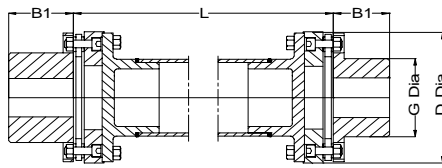

Series 80 SN

Series 80 SF

Size	Nominal HP/100 RPM	Nominal Torque Nm	Peak Torque Nm	Max Bore mm	D	G	B1
65	0.45	32	64	24	66	34	28
80	0.9	64	128	28	75	40	30
100	1.8	128	256	32	87	46	32
125	2.6	185	370	42	102	59	41
150	4	285	570	42	105	62	45
162	7	500	1000	48	115	71	48
180	9	640	1280	55	130	78	55
200	12	855	1710	55	143	84	54
220	15	1070	2140	65	143	93	62
225	18	1282	2562	65	148	93	67
250	25	1780	3560	80	173	114	76
262	33	2350	4700	80	173	114	76
300	56	3990	7980	90	203	128	86
312	56	3990	7980	100	203	140	86
350	70	4990	9980	105	227	150	95
375	100	7125	14250	115	252	170	102
425	140	9975	19950	120	273	178	108
450	170	12110	24220	135	293	194	114
500	270	19230	38460	155	333	226	127
550	400	28500	57000	180	373	256	148
600	500	35625	71250	190	412	276	153
700	800	57000	114000	220	470	318	178
750	1100	78375	156750	220	510	321	191
800	1600	114000	228000	240	553	349	210

Size	Weight		Inertia MR ²		End Float		Bolt Torque Nm
	SN Kg	SF Kg	SN Kg.m ²	SF Kg.m ²	SN mm	SF mm	
65	1.5	1.8	0.001	0.001	1.00	0.50	6
80	2.1	2.0	0.002	0.001	1.20	0.60	10
100	3.0	2.2	0.003	0.002	2.00	1.00	24
125	4.7	3.7	0.007	0.004	2.00	1.00	24
150	4.8	3.8	0.007	0.004	1.30	0.65	24
162	6.6	5.8	0.011	0.007	1.30	0.65	24
180	9.2	8.0	0.020	0.012	1.50	0.75	48
200	11.0	9.7	0.030	0.018	1.80	0.90	48
220	13.5	13.5	0.043	0.026	2.00	1.00	48
225	14.5	13.5	0.044	0.027	1.40	0.70	48
250	20	19	0.082	0.050	2.20	1.10	48
262	20	19	0.082	0.050	1.50	0.75	48
300	34	31	0.19	0.116	3.00	1.50	200
312	30	27	0.17	0.104	1.90	0.95	80
350	42	35	0.30	0.18	2.00	1.00	200
375	55	49	0.47	0.29	2.30	1.15	200
425	75	64	0.77	0.47	2.50	1.25	400
450	97	on req	1.15	on req	2.80	1.40	400
500	122	on req	1.95	on req	3.00	1.50	400
550	155	on req	3.0	on req	3.20	1.60	540
600	205	on req	4.9	on req	3.70	1.85	700
700	314	on req	9.8	on req	4.10	2.05	1400
750	395	on req	14.2	on req	4.60	2.30	1800
800	580	on req	26.0	on req	5.00	2.50	2400

Note - Mass and Inertia are excluding tube and at max bore. Max misalignment 0.5 deg/pack
 For Maximum Length , Permissible speeds and Tube Dia - see Selection Table.

Unique Transmission (India) Pvt Ltd



Metaflex Vertical Floating Shaft Coupling

Size	Nominal HP/100 RPM	Nominal Torque Nm	Peak Torque Nm	Max Bore mm	D	G	B1
65	0.45	32	64	28	66	42	28
80	0.9	64	128	38	75	54	30
100	1.8	128	256	42	87	60	32
125	2.6	185	370	48	102	70	41
150	4	285	570	48	105	69	45
162	7	500	1000	55	115	80	48
180	9	640	1280	65	130	90	55
200	12	855	1710	70	143	100	54
220	15	1070	2140	80	143	112	62
225	18	1282	2562	75	148	110	67
250	25	1780	3560	80	173	130	76
262	33	2350	4700	90	173	130	76
300	56	3990	7980	110	203	157	86
312	56	3990	7980	110	203	157	86
350	70	4990	9980	115	227	162	95
375	100	7125	14250	130	252	187	102
425	140	9975	19950	130	273	191	108
450	170	12110	24220	145	293	211	114
500	270	19230	38460	175	333	251	127
550	400	28500	57000	190	373	270	148
600	500	35625	71250	210	412	as reqd	153
700	800	57000	114000	240	470	as reqd	178
750	1100	78375	156750	270	510	as reqd	191
800	1600	114000	228000	300	553	as reqd	210

Series 80 SV

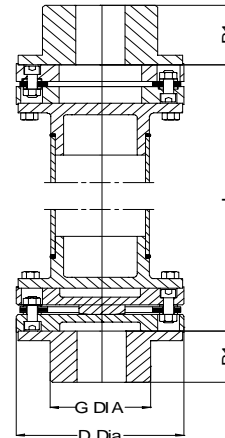

Size	Weight		Inertia MR^2		End Float		Bolt Torque Nm	Bolt Torque ##
	SV	SF	SV	SF	SV	SF(*)		
	Kg	Kg	Kg.m^2	Kg.m^2	mm	mm	#	##
65	1.9	2.0	0.001	0.001	1.00	0.50	6	6
80	2.7	2.3	0.002	0.002	1.20	0.60	10	6
100	4.1	2.7	0.004	0.003	2.00	1.00	24	10
125	6.0	4.3	0.009	0.005	2.00	1.00	24	24
150	6.1	4.4	0.009	0.005	1.30	0.65	24	24
162	8.1	6.6	0.014	0.008	1.30	0.65	24	48
180	11.0	9.5	0.027	0.016	1.50	0.75	48	48
200	14.0	11.2	0.040	0.024	1.80	0.90	48	48
220	16.8	15.1	0.043	0.026	2.00	1.00	48	48
225	17.5	13.5	0.044	0.027	1.40	0.70	48	48
250	24.4	21.2	0.105	0.064	2.20	1.10	48	48
262	24.2	21.1	0.105	0.064	1.50	0.75	48	48
300	43.2	35.7	0.25	0.152	3.00	1.50	200	80
312	36.8	30.4	0.22	0.134	1.90	0.95	80	80
350	53	40.5	0.40	0.244	2.00	1.00	200	200
375	68	55.6	0.60	0.366	2.30	1.15	200	200
425	94	74	1.00	0.61	2.50	1.25	400	400
450	121	on req	1.48	on req	2.80	1.40	400	400
500	150	on req	2.49	on req	3.00	1.50	400	400
550	187	on req	3.8	on req	3.20	1.60	540	540
600	255	on req	6.7	on req	3.70	1.85	700	700
700	388	on req	12.8	on req	4.10	2.05	1400	1400
750	480	on req	17.7	on req	4.60	2.30	1800	1400
800	680	on req	30.0	on req	5.00	2.50	2400	1400

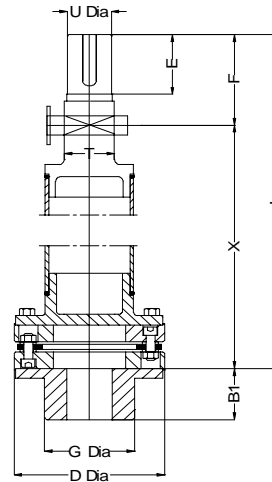

Type SF

Note - Mass and Inertia are excluding tube and at max bore. Max misalignment 0.5 deg/pack

For Maximum Length, Permissible speeds and Tube Dia - see Selection Table.

(+) indicates only axial extension, (-) indicates axial compression, (*) indicates expansion as well as compression

Also Available SV Adjustable with Shrink Discs or Splines - Details on Request

Unique Transmission (India) Pvt Ltd

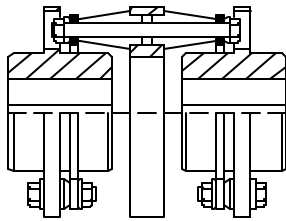

DBZ

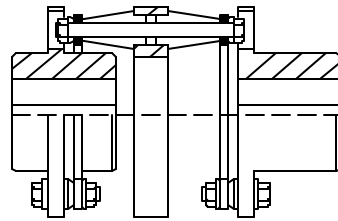

DBZ-A

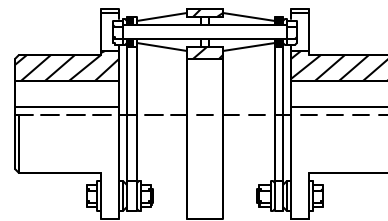

DBZ- B

Metaflex Couplings Type DBZ-DBZ-A and DBZ-B are designed for light and medium duty service at slow as well as high speeds. Their main use is for electric motor /turbine and gearbox driven equipments which are relatively free from shock loads or reversing torques. These couplings accommodate misalignment in all directions as well as end float. Type DBZ has a very compact construction with small gap between shaft ends. Type DBZ-A has one hub extended to accommodate a lock nut on one shaft or higher DBSE. Type DBZ-B has both hubs extended for lock nuts on both shafts or for greater DBSE.

Type DBZ-C couplings are spacer Type Couplings. The spool type spacer can be taken out to remove Pump seals and servicing without having to shift either of connected machines. The couplings are available with standard spacer lengths & can also be supplied with special spacer length.

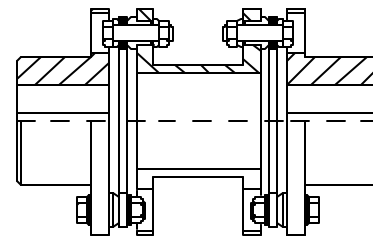

Type AMR Couplings are designed for heavy duty applications at slow to medium speeds. These are very suitable for heavy duty motor and diesel engine drives with high starting torques , shock load or reversing load. The open lug type center member gives adequate clearance for bolt removal while requiring minimum space for machine installation. The center member can be removed without having to shift connected machines.

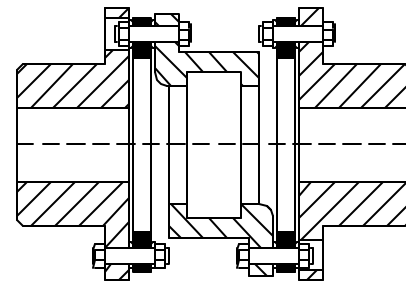

Type CMR Couplings are similar to the Type AMR except that one hub is substituted by a flange adaptor plate . This makes the coupling specially suitable for direct attachment to the Flywheel of engines , reciprocating compressors etc without an extension shaft.

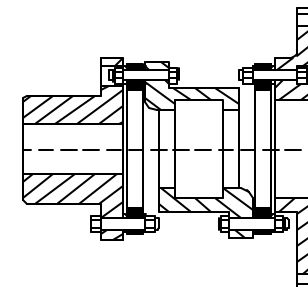



Metaflex Coupling Series 52 are high speed as well as high torque capacity couplings. The construction is in spacer design with central spacer member being removable without having to shift either driving or driven machine. The discs are loose (not unitized) . The couplings have comparatively low moment of Inertia & high torsional stiffness.

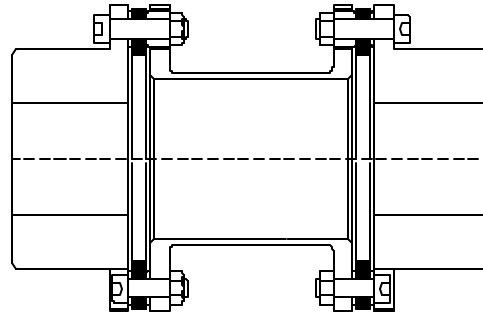

Series 52SPL – This is a simple variation of Series 52 design with Large Hub at one end & standard hub at other end. This is specially suitable when one of the shaft is of comparatively large diameter , while other shaft is of normal diameter - typically Motor at one end & Pump at other end.

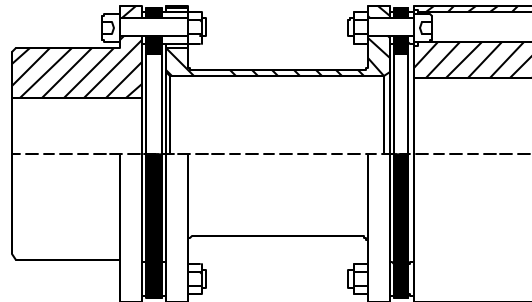

Series 52SP – This is also simple variation of Series 52 design with Large Hub at both ends. This is specially suitable when both shaft are of comparatively large diameter.

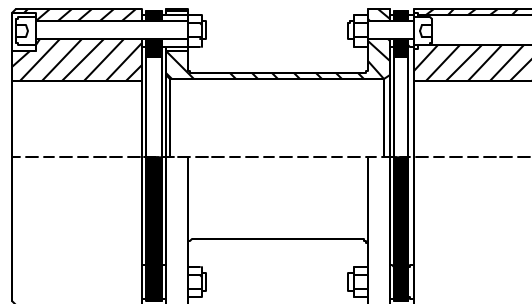

Series 54 – The design permits very small distance between shaft ends. The design is ideal for applications where nonspacer Gear Couplings are to be replaced by Metaflex Couplings. The design has twin disc packs & accommodates misalignment in all directions. The design however requires either driving or driven machine to be shifted for removal of disc packs.

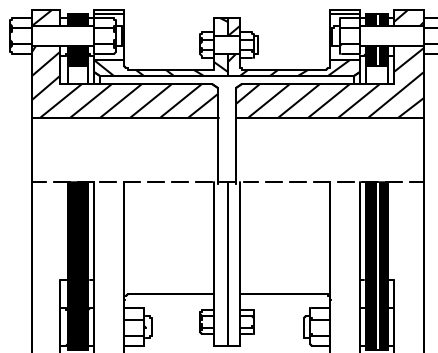

Unique Transmission (India) Pvt Ltd



Metaflex Flexible Disc Coupling

DBZ

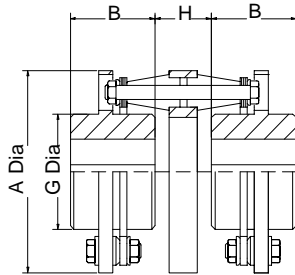

DBZ-A

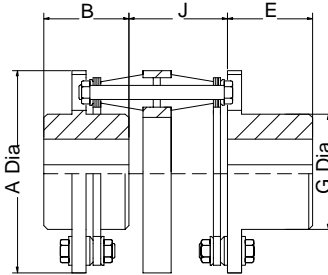

DBZ-B

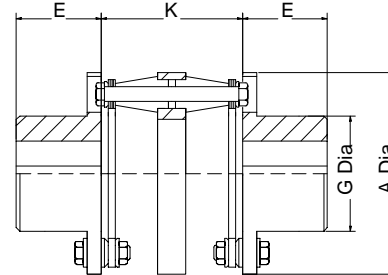

Dimensions and Standard Sizes

Size	Rating HP/100 RPM	Max Bore mm	Max Speed RPM	A Dia mm	B mm	E mm	G mm	H mm	J mm	K mm
50	0.25	18	9000	51	22	22	25	8	13	25
62	0.42	20	8200	62	28	28	30	10	44	30
75	0.6	25	7800	68	29	29	37	10	27	45
101	1.2	29	7100	83	35	35	43	18	35	52
126	2.4	35	6500	98	38	41	52	24	43	62
163	3.5	50	6000	117	43	48	70	24	43	62
201	5.3	55	5500	138	49	54	83	24	49	75
226	11.0	65	5200	156	60	67	96	30	64	97
263	15.0	75	4800	181	70	76	113	33	71	110
301	22.3	90	4500	208	79	87	129	38	81	124
351	44.9	100	4100	241	94	103	148	45	97	149
401	57	112	3900	279	106	118	168	49	110	170
451	75	125	3600	321	121	133	187	54	119	184

Engineering Data

Size	Weight Kg	Inertia MR ² KgM ²	Torsional Stiffness MNM/Rad	End Float + - mm	Max parallel Misalignment mm	Bolt Tightening Torque Nm
50	0.3	0.0001	0.003	0.60	0.17	2.7
62	0.7	0.0002	0.005	0.70	0.20	4
75	0.9	0.0005	0.007	0.80	0.20	4
101	1.5	0.0014	0.016	0.96	0.23	11
126	2.5	0.0032	0.075	1.16	0.27	18
163	3.9	0.0067	0.100	1.45	0.27	18
201	6.8	0.0170	0.170	1.70	0.33	34
226	10.0	0.0310	0.320	1.95	0.40	58
263	15.5	0.0674	0.500	2.25	0.47	85
301	23.5	0.1210	0.800	2.60	0.56	130
351	38.5	0.3020	1.500	3.00	0.66	240
401	59.0	0.5520	2.000	3.50	0.76	270
451	82.0	1.0220	2.500	3.90	0.83	350

Multiply MR² Inertia figures by 4 to obtain GD² values. Weight & Inertia are at maximum bore.
 Permissible Angular misalignment is 1.0 degree at 1500 rpm and 0.5 degree at 3000 rpm per disc pack.
 Standard construction has hubs class 2 IS 2004 & Disc Packs Stainless Steel. Alternative materials
 can be furnished on request. For plated bolts reduce tightening torque by 20 %.
 Couplings can be supplied with different dimensions H , J, K (DBSE) on request

Metaflex Coupling Series DBZ-C



Riddhi Engineering Company

www.couplings-mounts.com

sales@riddhiengineeringco.com

+91 74900 32784

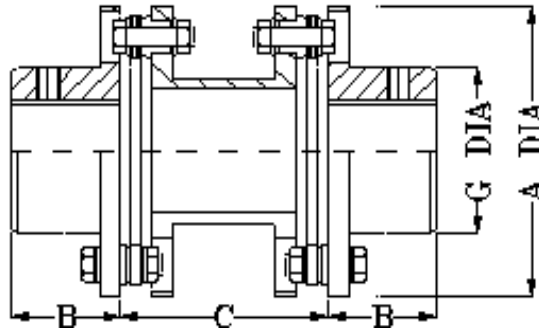

SIZE	RATING HP/100 RPM	MAX BORE MM	MAX SPEED RPM	A DIA	B	G DIA	STANDARD SPACERS- C
					MM		
50	0.25	18	9000	51	22	25	100,140,180
62	0.42	20	8200	62	28	30	100,140,180
75	0.6	25	7000	68	29	37	100,140,180
101	1.2	29	7000	83	35	43	100,140,180
126	2.4	35	6500	98	41	52	100,140,180
163	3.5	50	6000	117	48	70	100,140,180,250
201	5.3	55	5500	138	54	83	100,140,180,250
226	11.0	65	5200	156	67	96	100,140,180,250,300
263	15.0	75	4800	181	76	113	140,180,250,300,350
301	22.3	90	4500	208	87	129	140,180,250,300,350
351	44.9	100	4100	241	103	148	140,180,250,300,350
401	57.0	112	3900	279	118	168	180,250,300,350
451	75.0	125	3600	321	133	187	180,250,300,350

SIZE	WEIGHT KG	INERTIA MR ² KG.CM ²	WEIGHT CHANGE KG/CM	INERTIA CHANGE KGCM ² /CM	END FLOAT + - MM	BOLT TIGHT TORQUE NM
50	0.45	1.3	0.014	0.018	0.60	2.7
62	0.8	4.1	0.016	0.030	0.70	4
75	1.1	5.4	0.020	0.060	0.80	4
101	2.2	18	0.050	0.180	0.96	11
126	3.4	38	0.080	0.414	1.16	18
163	5.0	83	0.080	0.805	1.45	18
201	7.7	190	0.120	1.84	1.70	34
226	11.3	315	0.140	2.76	1.95	58
263	16.8	660	0.170	4.72	2.25	85
301	25.4	1290	0.220	7.94	2.60	130
351	42.2	2860	0.322	14.95	3.00	240
401	63.5	5800	0.48	29.9	3.50	270
451	90.7	10250	0.55	41.4	3.90	350

Multiply MR² Values by 4 to obtain GD² values. Weight & Inertia are at max bore with smallest standard spacer. For other spacers use weight & inertia change values to calculate actual figures.

Maximum permissible angular misalignment is 1.0 deg for 1500 RPM and 0.5 deg for 3000 RPM at each disc pack. Standard Construction has hubs, spacers of class 2 forged steel IS2004 and Disc Packs of Stainless steel. For plated bolts reduce Tightening Torques by 20%. Spacer Dimensions other than standard spacers can also be supplied.

Unique Transmission (India) Pvt Ltd 10/ID Lal Bazar Street, Calcutta 700001

Metaflex Coupling Series DBZ-C SPL

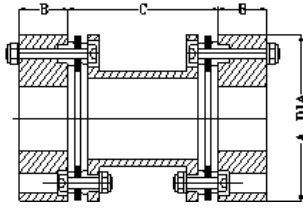

FIG 1- DBZC 62 SPL

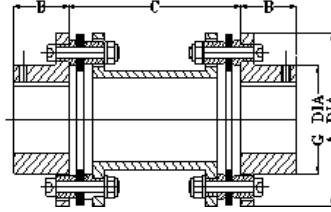

FIG 2 - DBZ-C 126 SPL , DBZ-C 201 SPL

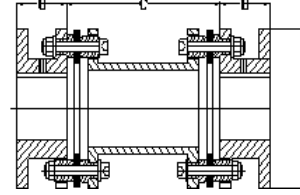

FIG 3 DBZ-C 163 SPL

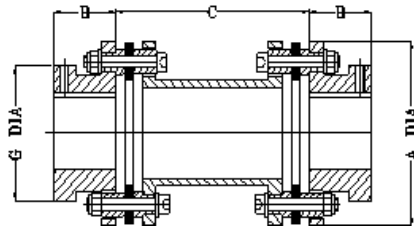

FIG 4 DBZ-C 226 SPL

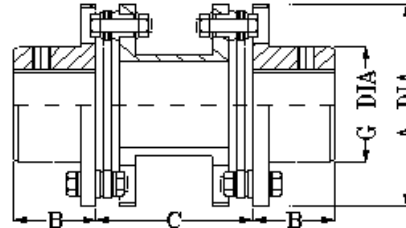

FIG 5 - DBZ-C 263SPL & LARGER

SIZE	RATING HP/100 RPM	MAX BORE MM	MAX SPEED RPM	A DIA	B	G DIA	FIG	STANDARD SPACERS- C
62SPL	0.42	28	9000	62	22	-	1	100,140,180
126SPL	2.4	42	6500	98	28	60	2	100,140,180
163SPL	3.5	55	6000	117	36	-	3	100,140,180,250
201SPL	5.3	65	5500	138	54	90	2	140,180,250
226SPL	11.0	75	5200	156	58	114	4	140,180,250,300
263SPL	15.0	75	4800	181	76	113	5	140,180,250,300
301SPL	22.3	90	4500	208	82	129	5	180,250,300,350
351SPL	44.9	100	4100	241	82	148	5	180,250,300,350
401SPL	57.0	112	3900	279	105	168	5	180,250,300,350
451SPL	75.0	125	3600	321	133	187	5	180,250,300,350

SIZE	WEIGHT KG	INERTIA MR ² KG.CM ²	WEIGHT CHANGE KG/CM	INERTIA CHANGE KGCM ² /CM	END FLOAT + - MM	BOLT TIGHT TORQUE NM
62SPL	1.5	7.9	0.016	0.03	0.70	4
126SPL	3	36	0.08	0.41	1.16	18
163SPL	5	97	0.08	0.81	1.45	18
201SPL	9.6	215	0.12	1.84	1.70	34
226SPL	12.3	359	0.14	2.76	1.95	58
263SPL	16.8	660	0.17	4.72	2.25	85
301SPL	24.4	1320	0.22	7.94	2.60	130
351SPL	40.5	2970	0.32	14.95	3.00	240
401SPL	63.5	5800	0.48	29.9	3.50	270
451SPL	90.7	10250	0.55	41.4	3.90	350

Multiply MR² Values by 4 to obtain GD² values. Weight & Inertia are at max bore with smallest standard spacer. For other spacers use wight & inertia change values to calculate actual figures. Maximum permissible angular misalignment is 1.0 deg for 1500 RPM and 0.5 deg for 3000 RPM at each disc Pack .Standard Construction has hubs , spacers of class2 forged steel IS2004 and Disc Packs of Stainless steel. For plated bolts reduce Tightening Torques by 20 % . Spacer Dimensions other than standard spacers can also be supplied

Unique Transmission (India) Pvt Ltd 10/ID Lal Bazar Street ,Calcutta 700001

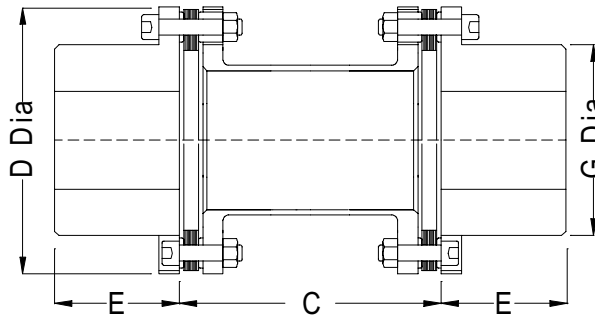

**METAFLEX
COUPLING
SERIES 52**

SIZE	NOMINAL HP/100 RPM	RATING TORQUE NM	PEAK TORQUE NM	MAX SPEED RPM	MAX BORE MM	E,HUB LENGTH MM	D DIA MM	G DIA MM	STD C MM
100	1.8	128	256	15000	32	32	83	46	90
125	3.7	263	526	15000	42	41	98	59	100
162	6.9	491	982	13900	48	48	111	71	140
200	13.5	962	1924	11200	55	54	138	84	140
225	19.0	1353	2706	10450	65	67	145	95	140
262	27.8	1980	3960	9200	80	76	168	114	140
312	38.6	2750	5500	7800	95	86	198	140	140
350	73.6	5243	10486	7000	105	95	221	150	140
375	98.6	7025	14050	6300	115	102	246	170	180
425	114	8120	16240	5800	120	108	267	178	180
450	137	9760	19520	5400	135	114	287	194	200
500	257	18310	36620	4700	155	127	327	226	225
550	341	24290	48580	4200	180	148	367	256	250
600	471	33550	67100	3800	190	153	406	276	250
700	659	46945	93890	3300	220	178	464	318	275
750	846	60265	120530	3000	220	191	503	321	275
800	1103	78575	157150	3000	240	210	546	349	305
SIZE	MASS KG	INERTIA KG.M^2	MAX MISALIGNMENT		TOR STIFF MNM/RAD	AXIAL SPRING RATE N/MM	BOLT TORQUE		
			AXIAL MM	RADIAL MM			NM		
100	1.5	0.0010	0.9	0.6	0.07	50	10		
125	2.0	0.0020	0.9	0.8	0.07	70	24		
162	4.0	0.004	0.9	1.2	0.21	100	24		
200	6.0	0.013	0.9	1.2	0.24	190	48		
225	8.0	0.019	0.9	1.2	0.31	275	48		
262	13	0.043	1.1	1.2	0.50	350	48		
312	20	0.09	1.3	1.2	0.76	415	80		
350	28	0.16	1.4	1.2	1.10	500	200		
375	38	0.28	1.6	1.5	1.50	540	200		
425	50	0.42	1.7	1.5	2.35	725	400		
450	60	0.60	1.8	1.7	2.60	755	400		
500	88	1.12	2.1	1.9	4.30	920	400		
550	126	2.1	2.3	2.1	6.20	920	540		
600	169	3.4	2.6	2.1	7.60	900	700		
700	258	6.6	2.9	2.4	12.4	1230	900		
750	325	9.7	3.2	2.4	16.5	1480	1130		
800	415	14.8	3.5	2.6	ON REQ	ON REQ	1500		

MASS AND INERTIA ,STIFFNESS ARE AT MAX BORE WITH STANDARD SPACER.DIMENSION C LISTED ABOVE.OTHER C DIMENSIONS ARE AVAILABLE AS REQUIRED ON REQUEST.HUB DIMENSIONS CAN BE MODIFIED TO SUIT SPECIAL NEEDS. MAX ANGULAR MISALIGNMENT 0.50 DEG/PACK.MISALIGNMENT LIMITS ARE FOR SPEEDS UPTO 3000 RPM.FOR HIGHER SPEEDS CONSULT US .

Unique Transmission (India) Pvt Ltd
 Head Office 10/ID Lal Bazar Street ,Calcutta 700001



**Metaflex
 Coupling
 Series 54**

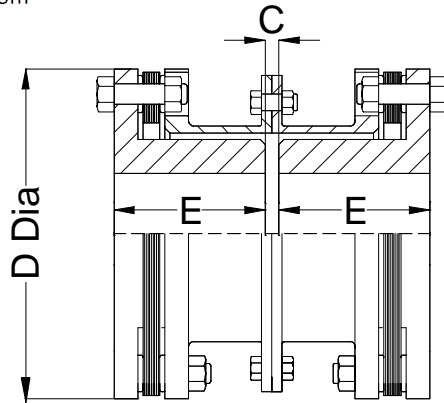

Size	Nominal HP/100 RPM	Rating Torque NM	Peak Torque NM	Max Speed RPM	Max Bore MM	B,Hub Length MM	A Dia MM	C MM
100	1.8	128	256	18650	25	39	83	3
125	3.7	263	526	15800	32	47	98	3
162	6.9	491	982	13900	42	48	111	3
200	13.5	962	1924	11200	53	54	138	3
225	19	1353	2706	10450	58	58	145	3
262	27.8	1980	3960	9200	70	66	168	5
312	38.6	2750	5500	7800	85	72	198	5
350	73.6	5243	10486	7000	100	83	221	6
375	98.6	7025	14050	6300	105	90	246	6
425	114	8120	16240	5800	110	101	267	6
450	137	9760	19520	5400	120	114	287	8
500	257	18310	36620	4700	140	120	327	8
550	341	24290	48580	4200	160	135	367	10
600	471	33550	67100	3800	175	153	406	10
700	659	46945	93890	3300	180	178	464	10
750	846	60265	120530	3000	190	197	503	12
800	1103	78575	157150	3000	203	210	546	12

Size	Mass KG	Inertia MR ² KG.M ²	Maximum Misalignment		Torsional Stiff MNM/Rad	Axial Spring Rate N/MM	Bolt Tight Torque	
			AXIAL MM	RADIAL MM			#	##
							NM	MM
100	1.8	0.001	0.9	0.6	0.07	50	10	6
125	2.5	0.002	0.9	0.8	0.07	70	24	10
162	4.0	0.005	0.9	1.2	0.21	100	24	10
200	7.0	0.014	0.9	1.2	0.24	190	48	24
225	7.5	0.018	0.9	1.2	0.31	275	48	24
262	12.0	0.041	1.1	1.2	0.50	350	48	24
312	18.0	0.09	1.3	1.2	0.76	415	80	48
350	26.0	0.16	1.4	1.2	1.18	500	200	80
375	36.0	0.23	1.6	1.5	1.50	540	200	80
425	48.0	0.42	1.7	1.5	2.35	725	400	200
450	60.0	0.60	1.8	1.7	2.60	755	400	200
500	85.0	1.12	2.1	1.9	4.30	920	400	200
550	122.0	2.10	2.3	2.1	6.20	920	540	200
600	164.0	3.40	2.6	2.1	7.60	900	700	400
700	250.0	6.60	2.9	2.4	12.4	1230	1400	540
750	305.0	9.70	3.2	2.4	16.5	1480	1800	700
800	393.0	14.80	3.5	2.6	ON REQ	ON REQ	2400	700

Mass , Inertia,Stiffness are at max bore with standard dimension C listed above. Other C Dimension C dimension are available as required on request .Hub dimensions can be modified to suit special needs. Max angular misalignment 0.50 Deg /Pack .Misalignment limits are for speeds upto 3000 RPM. For higher Speeds consult us . Bolt Tightening Torques - # for Disc Pack Bolts , ## for spacer bolts .

Unique Transmission (India) Pvt Ltd

10/ID Lal Bazar Street ,Calcutta 700001

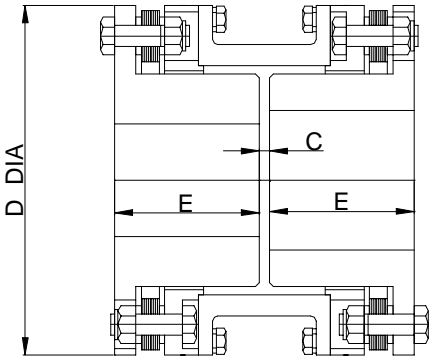

**Metaflex
Coupling
Series 54 CCS**

** Spacer in split Design
 ** Permits removal of Discs In situ without having to shift connected machines

Size	Nominal HP/100 RPM	Rating Torque NM	Peak Torque NM	Max Speed RPM	Max Bore MM	E, Hub Length MM	D Dia MM	C MM
100	1.8	128	256	7400	25	39	83	3
125	3.7	263	526	7200	32	47	98	3
162	6.9	491	982	7000	42	48	111	3
200	13.5	962	1924	6300	53	54	138	3
225	17	1211	2422	6000	58	58	145	3
262	27.8	1980	3960	5500	70	66	168	5
312	38.6	2750	5500	5000	85	72	198	5
350	54.1	3854	7708	4500	100	83	221	6
375	81.1	5777	11554	4000	105	92	246	6
425	115	8192	16384	3700	110	101	267	6
450	130	9261	18522	3400	120	114	287	8
500	197	14035	28070	3300	140	120	327	8
550	341	24290	48580	2800	160	135	367	10
600	427	30420	60840	2500	175	153	406	10
700	549	39110	78220	2500	180	178	464	10

Size	Mass KG	Inertia MR^2 KG.M^2	Maximum Misalignment		Disc pack bolt TT NM
			AXIAL MM	RADIAL MM	
100	1.8	0.001	0.9	0.6	10
125	3.1	0.0035	0.9	0.8	24
162	4.4	0.007	0.9	1.2	24
200	7.3	0.019	0.9	1.2	48
225	8.2	0.024	0.9	1.2	48
262	14.1	0.053	1.1	1.2	48
312	22.0	0.12	1.3	1.2	80
350	31.0	0.21	1.4	1.2	200
375	43.0	0.36	1.6	1.5	200
425	57.0	0.56	1.7	1.5	400
450	75.0	0.85	1.8	1.7	400
500	110.0	1.59	2.1	1.9	400
550	158.0	2.88	2.3	2.1	540
600	218.0	4.84	2.6	2.1	700
700	324.0	9.35	2.9	2.4	1400

Mass , Inertia, Stiffness are at max bore with standard dimension C listed above. Other C Dimension C dimension are available as required on request .Hub dimensions can be modified to suit special needs. Max angular misalignment 0.50 Deg /Pack .Misalignment limits are for speeds upto 3000 RPM. For higher Speeds consult us . Bolt Tightening Torques - # for Disc Pack Bolts , ## for spacer bolts .

Unique Transmission (India) Pvt Ltd
 10/ID Lal Bazar Street , Calcutta 700001

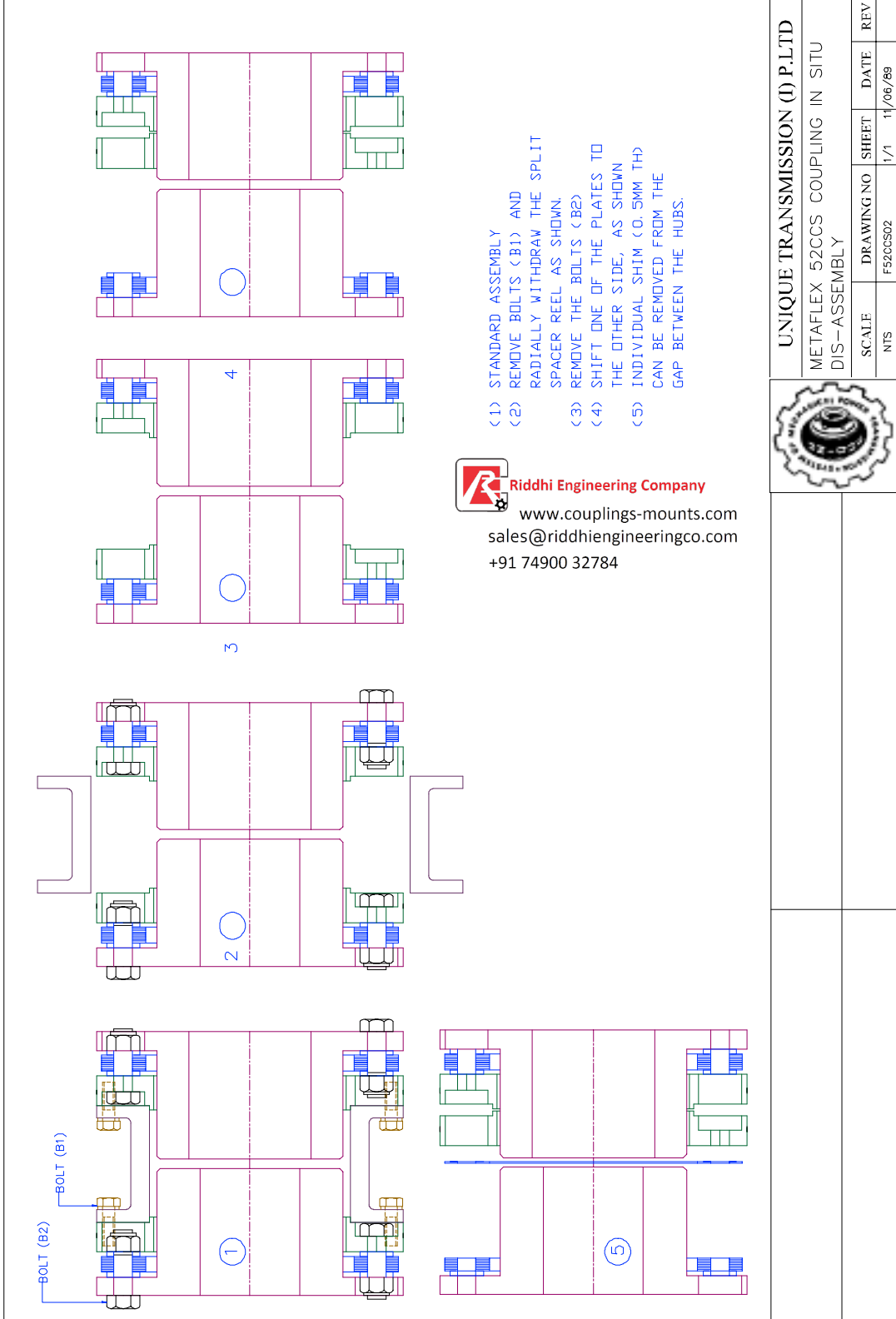

UNIQUE TRANSMISSION (I) P.LTD

METAFLEX 52CCS COUPLING IN SITU
DIS-ASSEMBLY

SCALE	DRAWING NO	SHEET	DATE	REV
NTS	F52CCS02	1/1	11/06/89	



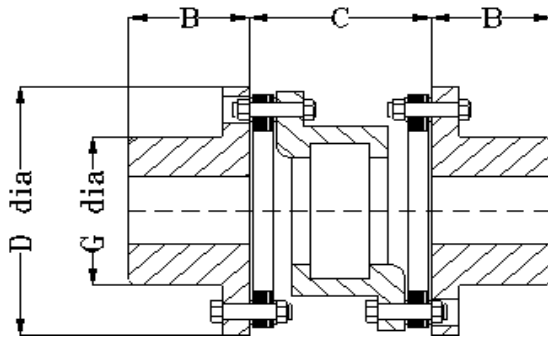

Metaflex Flexible Disc Coupling Series AMR

Size	Nominal HP/100 RPM	Nominal Rating Torque Nm	Peak Torque Rating Nm	Max Speed RPM	Max Bore mm	D mm	B mm	C mm	G mm
162	6.9	490	590	2500	42	117	44	67	70
200	13.5	960	1150	2500	55	146	54	76	84
225	19	1350	1620	2500	60	153	64	76	95
262	24.3	1730	2075	2500	70	175	73	89	114
312	34.1	2425	2910	2500	85	206	86	105	138
350	76.2	5420	6505	2500	90	232	95	116	152
375	99.7	7095	8515	2200	100	256	102	130	165
425	127	9035	10840	2000	110	279	108	141	177
450	157	11170	13405	1900	115	302	114	151	189
500	232	16505	19805	1800	130	341	127	173	213
550	300	21345	25615	1800	150	381	140	195	240
600	414	29455	35345	1500	160	425	153	215	262
700	659	46890	56270	1250	180	481	178	245	298
750	846	60190	72230	1100	200	524	184	267	321
800	1087	77340	92810	1000	215	568	197	289	349
850	1297	92280	110735	1000	225	603	210	308	368
925	1651	117470	140965	1000	250	654	229	337	403
1000	2063	146780	176135	900	275	718	241	368	445

Size	Mass Kg	Inertia MR ² Kg.m ²	Maximum Misalignment		Torsional Stiffness MNm/Rad	Bolt Tightening Torque Nm
			Axia mm	Radial mm		
162	6	0.006	0.91	0.58	0.25	24
200	9	0.017	0.91	0.66	0.43	48
225	10	0.023	0.91	0.66	0.84	48
262	15	0.047	1.09	0.77	1.3	48
312	25	0.112	1.3	0.92	2.3	80
350	34	0.194	1.42	1.01	2.9	200
375	50	0.32	1.57	1.13	4.1	200
425	59	0.47	1.7	1.23	5.9	400
450	73	0.68	1.83	1.32	7	400
500	100	1.2	2.08	1.51	10	400
550	136	2.15	2.33	1.7	16	540
600	170	3.22	2.59	1.88	18	700
700	260	6.3	2.92	2.14	29	900
750	315	9.5	3.18	2.33	38	1130
800	405	17.2	3.45	2.52	on req	on request
850	500	20.3	3.65	2.69	on request	
925	630	31	3.96	2.94	on request	
1000	910	48	4.36	3.2	on request	

Mass , Inertia & stiffness are at max bore. Standard construction has hubs in close grained cast iron for all sizes.
 Centre member are of cast iron upto size 600 and forged steel for larger sizes. Disc packs are of stainless steel for
 all sizes. Alternative materials including forged steel hubs with larger bore capacity available on request

Unique Transmission (India) Pvt. Ltd.

METAFLEX FLEXIBLE DISC COUPLING SERIES 80-AMR

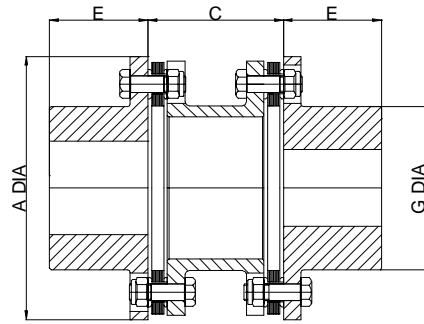

SIZE	NOMINAL HP/100 RPM	RATING TORQUE NM	PEAK TORQUE NM	MAX SPEED RPM	MAX BORE MM	A MM	E MM	C MM	G MM
162	7	500	625	2500	42	117	44	85	70
200	12	855	1070	2500	55	146	54	100	84
225	18	1282	1605	2500	60	153	64	100	95
262	33	2350	2940	2500	70	175	73	115	114
312	56	3990	4990	2500	85	206	86	135	138
350	70	4990	6240	2300	90	232	95	150	152
375	100	7125	8910	2200	100	256	102	170	165
425	140	9975	14470	1900	110	279	108	180	177
450	170	12110	15140	1500	115	302	114	195	189
500	270	19230	24040	1500	130	341	127	222	213
550	400	28500	35625	1500	150	381	140	250	240
600	500	35625	44530	1200	160	425	153	276	262
700	800	57000	71250	1100	180	481	178	316	298
750	1100	78375	97970	1000	200	524	184	343	321
800	1600	114000	142500	900	215	568	197	375	349

SIZE	ENGINEERING DATA					
	MASS	INERTIA	MAXIMUM MISALIGNMENT		TORSIONAL STIFFNESS	BOLT TORQUE
	KG	KG.M ²	AXIAL MM	RADIAL MM	MNM/RAD	NM
162	6	0.01	1.3	0.58	0.25	24
200	9	0.02	1.8	0.66	0.43	48
225	10	0.02	1.4	0.66	0.84	48
262	15	0.05	1.5	0.77	1.33	48
312	25	0.11	1.9	0.92	2.2	80
350	34	0.19	2.0	1.01	2.9	200
375	50	0.32	2.3	1.13	4.0	200
425	59	0.47	2.5	1.23	5.9	400
450	73	0.68	2.8	1.32	7	400
500	100	1.20	3.0	1.51	10	400
550	136	2.15	3.2	1.7	16	540
600	170	3.22	3.7	1.88	18	700
700	260	6.30	4.1	2.14	29	1400
750	315	9.50	4.6	2.33	38	1400
800	405	17.20	5.0	2.52	51	on req

Mass , Inertia, Stiffness are at max bore with standard spacer dimension C listed above. Other C dimension are available as required on request. Hub dimensions can be modified to suit special needs.
 Max angular misalignment 0.50 Deg /Pack .

METAFLEX FLEXIBLE DISC COUPLING SERIES CMR

ADAPTAR TYPE	OD INCH	BOLTING LIGHT DUTY SAE			BOLTING UNIQUE HEAVY DUTY		
		PCD INCH	NO OF HOLES	SIZE INCH	PCD INCH	NO OF HOLES	SIZE INCH
A	8.500/8.498	7.875	6	11/32	7.500	8	13/32
B	9.500/9.498	8.750	8	11/32	8.625	8	15/32
C	10.375/10.373	9.625	6	13/32	9.500	8	15/32
D	12.375/12.373	11.625	8	13/32	11.500	8	17/32
E	13.875/13.873	13.125	8	13/32	12.500	8	21/32
F	16.000/15.998	-	-	-	14.375	8	25/32
G	18.375/18.373	17.250	8	17/32	16.750	8	25/32
H	20.375/20.372	19.250	8	17/32	18.500	8	29/32
I	22.500/22.497	21.375	6	21/32	20.500	8	1/1/1932
J	26.500/26.497	25.250	12	21/32	24.500	12	1/1/1932
K	28.875/28.872	27.250	12	25/32	26.875	12	1/1/1932

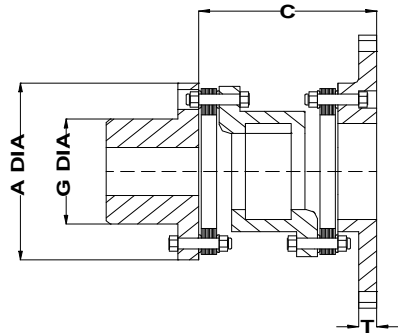

SIZE	NOMINAL HP/100 RPM	RATING TORQUE NM	PEAK TORQUE NM	MAX SPEED RPM	MAX BORE MM	A MM	E MM	C MM	G MM	T MM
162	6.9	490	590	2500	42	117	44	85	70	8
200	13.5	960	1150	2500	55	146	54	100	84	10
225	19	1350	1620	2500	60	153	64	100	95	10
262	24.3	1730	2075	2500	70	175	73	115	114	11
312	34.1	2425	2910	2500	85	206	86	135	138	13
350	76.2	5420	6505	2300	90	232	95	150	152	13
375	99.7	7095	8515	2200	100	256	102	170	165	14
425	127	9035	1084	1900	110	279	108	180	177	18
450	157	11170	13405	1500	115	302	114	195	189	16
500	232	16505	19805	1500	130	341	127	222	213	19
550	300	21345	25615	1500	150	381	140	250	240	22
600	414	29455	35345	1200	160	425	153	276	262	25
700	659	46890	56270	1100	180	481	178	316	298	25
750	846	60190	72230	1000	200	524	184	343	321	29
800	1087	77340	92810	900	215	568	197	375	349	32
850	1297	92280	110735	850	225	603	210	400	368	32
925	1651	117470	140965	800	250	654	229	438	403	35

SIZE	MASS KG	INERTIA KG.M ²	ENGINEERING DATA MISALIGNMENT			TORSIONAL STIFFNESS MNM/RAD	F.WHEEL STD ADAPTARS	BOLT TORQUE NM
			AXIAL MM	RADIAL MM	MAXIMUM TORQUE NM			
162	4	0.01	0.91	0.58	0.30	A,B,C,D	24	
200	6	0.02	0.91	0.66	0.51	A,B,C,D,E	48	
225	8	0.04	0.91	0.66	0.97	A,B,C,D,E	48	
262	12	0.06	1.09	0.77	1.49	A,B,C,D,E,F,G	48	
312	19	0.11	1.30	0.92	2.69	B,C,D,E,F,G,H	80	
350	26	0.19	1.42	1.01	4.0	D,E,F,G,H,I	200	
375	35	0.30	1.57	1.13	4.9	D,E,F,G,H,I	200	
425	46	0.52	1.70	1.23	7.1	E,F,G,H,I	400	
450	58	0.73	1.83	1.32	8.3	F,G,H,I,J	400	
500	82	1.4	2.08	1.51	12.5	F,G,H,I,J,K	400	
550	112	2.3	2.33	1.7	18.6	G,H,I,J,K	540	
600	150	3.6	2.59	1.88	19.3	H,I,J,K	700	
700	230	6.9	2.92	2.14	31.6	H,I,J,K	900	
750	280	10.0	3.18	2.33	39.0	J,K	1130	
800	365	17.2	3.45	2.52	58.0	J,K	1500	
850	445	21.5	3.65	2.69	ON REQ	ON REQ	1900	
925	540	31.4	4.00	2.94	ON REQ	ON REQ	2500	

Weight & Inertia figures are at maximum bore and minimum adaptor diameter. Maximum speed corresponds to smallest standard adaptor. Standard construction has hubs in close grain cast iron for all sizes. Centre spacer are cast iron upto size 600 and cast steel for larger sizes. Flywheel adaptars are of steel. Disc packs are of stainless steel for all sizes. Alternative materials including forged steel for hubs with larger bore capacity available on request.

UNIQUE TRANSMISSION I PVT LTD



Metaflex Flexible Disc Coupling - Flywheel adaptor Type - Series 80-CMR -SPL

ADAPTAR TYPE	OD INCH	BOLTING LIGHT DUTY SAE			BOLTING UNIQUE HEAVY DUTY		
		PCD	NO OF HOLES	SIZE	PCD	NO OF HOLES	SIZE
		INCH	INCH	INCH	INCH	INCH	INCH
A	8.500/8.498	7.875	6	11/32	7.500	8	13/32
B	9.500/9.498	8.750	8	11/32	8.625	8	15/32
C	10.375/10.373	9.625	6	13/32	9.500	8	15/32
D	12.375/12.373	11.625	8	13/32	11.500	8	17/32
E	13.875/13.873	13.125	8	13/32	12.500	8	21/32
F	16.000/15.998	-	-	-	14.375	8	25/32
G	18.375/18.373	17.250	8	17/32	16.750	8	25/32
H	20.375/20.372	19.250	8	17/32	18.500	8	29/32
I	22.500/22.497	21.375	6	21/32	20.500	8	1-1/32"
J	26.500/26.497	25.250	12	21/32	24.500	12	1-1/32"
K	28.875/28.872	27.250	12	25/32	26.875	12	1-1/32"

Spacer Length 460 mm on Request

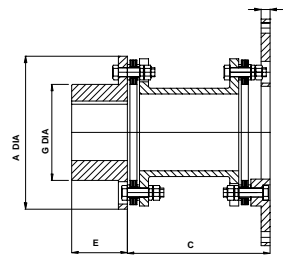

SIZE	NOMINAL HP/100 RPM	RATING TORQUE NM	PEAK TORQUE NM	MAX SPEED RPM	MAX BORE MM	A MM	E MM	C MM	G MM	T MM
162	7	500	1000	3000	42	117	44	85	70	8
200	13.5	960	1710	3000	55	146	54	100	84	10
225	19	1356	2564	3000	60	153	64	100	95	10
262	33	2350	4700	3000	70	175	73	115	114	11
312	56	3990	7980	3000	85	206	86	135	138	13
350	76.2	5425	10850	2750	90	232	95	150	152	13
375	100	7125	14250	2500	100	256	102	170	165	14
425	140	9975	19950	2200	110	279	108	180	177	18
450	170	12110	24220	1900	115	302	114	195	189	16
500	270	19230	38460	1800	130	341	127	222	213	19
550	400	28500	57000	1800	150	381	140	250	240	22
600	500	35625	71250	1800	170	425	153	276	262	25
Q600	800	57000	114000	1800	170	425	178	276	262	25
700	800	57000	114000	1500	200	481	178	316	298	25
Q700	1200	85500	171000	1500	200	481	184	316	298	25
750	1100	78375	156750	1500	220	524	184	343	321	29
Q750	1600	114000	228000	1500	220	524	197	343	321	29
800	1600	114000	228000	1200	240	568	197	375	349	32
Q800	2120	151000	302000	1200	240	568	197	375	380	32

SIZE	MASS Kg	ENGINEERING DATA				F.WHEEL STD ADAPTARS	BOLT TORQUE Nm
		INERTIA KgM ²	MAXIMUM MISALIGNMENT		TORSIONAL STIFFNESS MNm/Rad		
			AXIAL mm	RADIAL mm			
162	4	0.01	1.30	0.58	0.30	A,B,C,D	24
200	6	0.02	1.80	0.66	0.51	A,B,C,D,E	48
225	8	0.04	1.40	0.66	0.97	A,B,C,D,E	48
262	14	0.06	1.50	0.77	1.49	A,B,C,D,E,F,G	48
312	20	0.12	1.90	0.92	2.69	B,C,D,E,F,G,H	80
350	28	0.20	2.00	1.01	4.00	D,E,F,G,H,I	200
375	38	0.33	2.30	1.13	4.91	D,E,F,G,H,I	200
425	50	0.57	2.50	1.23	7.10	E,F,G,H,I	400
450	63	0.80	2.80	1.32	8.30	F,G,H,I,J	400
500	90	1.53	3.00	1.51	12.50	F,G,H,I,J,K	400
550	122	2.48	3.20	1.70	18.60	G,H,I,J,K	540
600	160	3.96	3.70	1.88	19.30	H,I,J,K	700
Q600	160	3.96	3.70	1.88	22.00	H,I,J,K	700
700	250	7.63	4.10	2.14	31.60	H,I,J,K	1400
Q700	250	7.63	4.10	2.14	35.00	H,I,J,K	1400
750	304	10.60	4.60	2.33	39.00	J,K	1400
Q750	304	10.60	4.60	2.33	42.00	J,K	1400
800	400	18.10	5.00	2.52	58.00	J,K	1400
Q800	400	18.10	5.00	2.52	60.00	J,K	2200

Max Bore capacity with rectangular Key

Mass and Inertia are at Max Bore with minimum Adaptor Diameter. Maximum Speed corresponds to smallest standard adaptor.

Hubs , Spacer , Adaptor Plate of Forged Steel ASTM A668 Gr F . Disc Packs of Stainless Steel

Bolts Gr 10.9 ASTM A490M , Lock Nuts ASTM A194 Gr 2H

Each Hub with 2 No Puller Holes

Hubs , Spacer Dynamically Balanced to 6350 W/N gm.mm , Assembly Check Balanced to 63500 W/N gm.mm

Other Spacer Length , Torsional Stiffness to customer requirement on request.



Metaflex Flexible Disc Coupling - Flywheel adaptor Type - Series 80-CMR -SPL

ADAPTAR TYPE	OD INCH	BOLTING LIGHT DUTY SAE			BOLTING UNIQUE HEAVY DUTY		
		PCD	NO OF HOLES	SIZE	PCD	NO OF HOLES	SIZE
		INCH	INCH	INCH	INCH	INCH	INCH
A	8.500/8.498	7.875	6	11/32	7.500	8	13/32
B	9.500/9.498	8.750	8	11/32	8.625	8	15/32
C	10.375/10.373	9.625	6	13/32	9.500	8	15/32
D	12.375/12.373	11.625	8	13/32	11.500	8	17/32
E	13.875/13.873	13.125	8	13/32	12.500	8	21/32
F	16.000/15.998	-	-	-	14.375	8	25/32
G	18.375/18.373	17.250	8	17/32	16.750	8	25/32
H	20.375/20.372	19.250	8	17/32	18.500	8	29/32
I	22.500/22.497	21.375	6	21/32	20.500	8	1-1/32"
J	26.500/26.497	25.250	12	21/32	24.500	12	1-1/32"
K	28.875/28.872	27.250	12	25/32	26.875	12	1-1/32"

Spacer Length 460 mm on Request

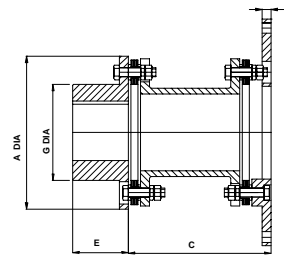

SIZE	NOMINAL HP/100 RPM	RATING TORQUE NM	PEAK TORQUE NM	MAX SPEED RPM	MAX BORE MM	A MM	E MM	C MM	G MM	T MM
162	7	500	1000	3000	48	117	44	85	70	8
200	13.5	960	1710	3000	60	146	54	100	84	10
225	19	1356	2564	3000	65	153	64	100	95	10
262	33	2350	4700	3000	80	175	73	115	114	11
312	56	3990	7980	3000	95	206	86	135	138	13
350	76.2	5425	10850	2750	100	232	95	150	152	13
375	100	7125	14250	2500	115	256	102	170	165	14
425	140	9975	19950	2200	125	279	108	180	177	18
450	170	12110	24220	1900	135	302	114	195	189	16
500	270	19230	38460	1800	150	341	127	222	213	19
550	400	28500	57000	1800	170	381	140	250	240	22
600	500	35625	71250	1800	185	425	153	276	262	25
Q600	800	57000	114000	1800	185	425	178	276	262	25
700	800	57000	114000	1500	210	481	178	316	298	25
Q700	1200	85500	171000	1500	210	481	184	316	298	25
750	1100	78375	156750	1500	225	524	184	343	321	29
Q750	1600	114000	228000	1500	225	524	197	343	321	29
800	1600	114000	228000	1200	245	568	197	375	349	32
Q800	2120	151000	302000	1200	245	568	197	375	380	32

SIZE	MASS Kg	ENGINEERING DATA				F.WHEEL STD ADAPTARS	BOLT TORQUE Nm
		INERTIA KgM ²	MAXIMUM MISALIGNMENT		TORSIONAL STIFFNESS MNm/Rad		
			AXIAL mm	RADIAL mm			
162	4	0.01	1.30	0.58	0.30	A,B,C,D	24
200	6	0.02	1.80	0.66	0.51	A,B,C,D,E	48
225	8	0.04	1.40	0.66	0.97	A,B,C,D,E	48
262	14	0.06	1.50	0.77	1.49	A,B,C,D,E,F,G	48
312	20	0.12	1.90	0.92	2.69	B,C,D,E,F,G,H	80
350	28	0.20	2.00	1.01	4.00	D,E,F,G,H,I	200
375	38	0.33	2.30	1.13	4.91	D,E,F,G,H,I	200
425	50	0.57	2.50	1.23	7.10	E,F,G,H,I	400
450	63	0.80	2.80	1.32	8.30	F,G,H,I,J	400
500	90	1.53	3.00	1.51	12.50	F,G,H,I,J,K	400
550	122	2.48	3.20	1.70	18.60	G,H,I,J,K	540
600	160	3.96	3.70	1.88	19.30	H,I,J,K	700
Q600	160	3.96	3.70	1.88	22.00	H,I,J,K	700
700	250	7.63	4.10	2.14	31.60	H,I,J,K	1400
Q700	250	7.63	4.10	2.14	35.00	H,I,J,K	1400
750	304	10.60	4.60	2.33	39.00	J,K	1400
Q750	304	10.60	4.60	2.33	42.00	J,K	1400
800	400	18.10	5.00	2.52	58.00	J,K	1400
Q800	400	18.10	5.00	2.52	60.00	J,K	2200

Max Bore capacity with rectangular Key

Mass and Inertia are at Max Bore with minimum Adaptor Diameter. Maximum Speed corresponds to smallest standard adaptor.

Hubs , Spacer , Adaptor Plate of Forged Steel ASTM A668 Gr F . Disc Packs of Stainless Steel

Bolts Gr 10.9 ASTM A490M , Lock Nuts ASTM A194 Gr 2H

Each Hub with 2 No Puller Holes

Hubs , Spacer Dynamically Balanced to 6350 W/N gm.mm , Assembly Check Balanced to 63500 W/N gm.mm

Other Spacer Length , Torsional Stiffness to customer requirement on request.

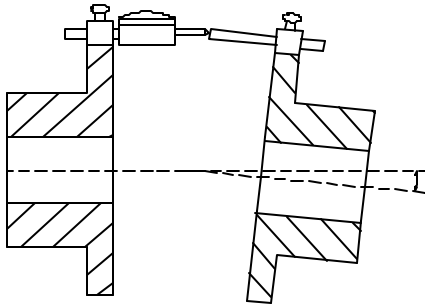
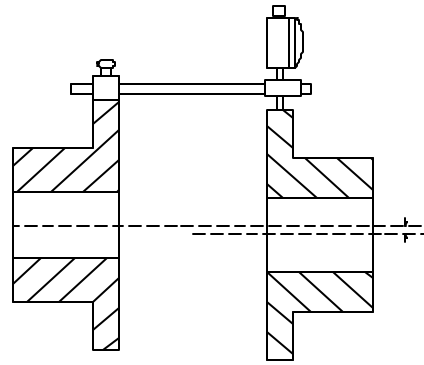
**Angular Alignment****Parallel Alignment**

General Alignment Instructions

Correct installation and alignment will assure long life and smooth trouble free service. It is recommended that coupling be aligned within 25 % of catalogue/drawing figures of misalignment capacity. For speeds higher than 3000 rpm alignment instructions are available on request.

Check for axial alignment

Check distance between shaft ends, if necessary shift either driving or driven machine to maintain correct distance between shaft ends (DBSE).

Check for angular misalignment

Dial indicator measures maximum longitudinal variation in hub spacing through 360 degree rotation.

1. Attach dial indicator to the hub with a hose clamp ; rotate coupling 360 degrees to locate point of minimum reading on dial. Next rotate body or face of dial indicator so that zero reading lines up with the pointer.

2. Rotate coupling 360 degree – watch indicator for misalignment reading.

3. Driver & driven units will be lined up when dial indicator reading within maximum allowable variation for that coupling style.- refer to specific installation sheet for the coupling type being installed.

4. Reset pointer to zero and repeat above operations 1 and 2 when either driver or driven unit is moved during alignment trial.

Check for Parallel Misalignment

Dial indicator measures displacement of one shaft center line from the other.

5. Check for parallel misalignment as shown. Move or shim units so that parallel misalignment is brought within maximum allowable variation for the coupling style.

6. Coupling should be rotated several revolutions to make sure that there is no “ endwise creep” in connected shafts.

7. Tighten all locknuts or cap screws.

8. Recheck and tighten all locknuts or cap screws after several hours of operation.

For spacer couplings with spacer lengths different from standard , permissible parallel misalignment is approximately proportional to length of spacer.(DBSE).

Note – Well aligned Coupling will have neat straight disc pack. Installation instructions are available on request.

Installation of Metaflex Flexible Disc Couplings

Series 80/80SPL/80SP/80X/80XSPL/80XSP/80Q/80QX

1. The Couplings are normally supplied fully assembled except for large size. Large size are supplied with spacer Assembly duly factory assembled, end hubs being separately packed.
2. In case of fully assembled couplings remove end hubs. For pilot bored hubs do finish boring keeping Flange OD & Face true. Hub should be cleaned – burrs to be removed. Mount hubs. The hub should not be hammered on the shaft or spot heated. If necessary the hub may be heated in oil up to temperature 200 deg C to facilitate fitment.
3. Align driving & driven hubs as per general alignment instruction.

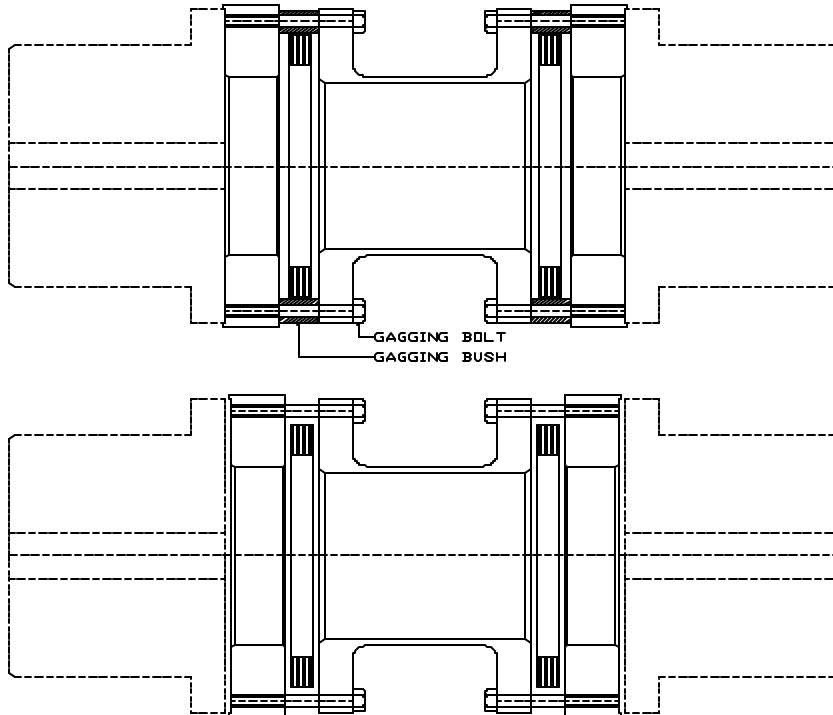

Riddhi Engineering Company

www.couplings-mounts.com

sales@riddhiengineeringco.com

+91 74900 32784

A set of plain bushes and bolts (**painted red**) are provided between side plate and spacer reel on either side. These are only meant to protect the flexible disc packs against transit damage. ***It is absolutely essential to remove these bushes and bolts before the coupling is installed.***

After removing the gagging bolts and bushes reinsert just the bolts (without bushes) in position and manually engage into the threaded holes. Now tighten these bolts gradually and successively just enough to pre-compress the spacer assembly so that its length over spigots reduces to the installed distance between the coupling hubs. ***Care must be taken not to overdo the tightening of gagging bolts as this may deform the disc packs.*** Now the spacer assembly can be easily inserted in the gap between the hubs. Holding it in position, unscrew the gagging bolts. This will cause the spacer assembly to spring back to its normal length and engage the spigots. Care should be taken to ensure that the spigots on both sides sit properly on hub flange diameters. The gagging bolts should be completely removed from the assembly and kept safely for future use.

Removal:

For removing the spacer assembly from installation follow the same procedure as above. Gradual and successive tightening of all gagging bolts will release the spigots after which the spacer assembly can be easily dropped down. ***Once again care must be taken not to overdo the tightening of gagging bolts as this may deform the disc packs.***

Special note: In coupling sizes 80/65,80,100,125 and 300 the tapped holes provided in the side plate for fixing the hub are also used for gagging bush/bolt because of design considerations. Hence, these sizes are shipped with hubs detached from spacer sub assembly. The hubs and the hub fixing bolts are packed separately. This is of no real consequence because the gagging bushes/bolts are in any case removed from the sub assembly before attaching it to the hubs. Once the gagging bush/bolts are removed, the tapped holes in the side plate are available for hub fixing.

4. Check spacer subassembly bolts are tightened to torque specified in catalogue/drawing.
5. Insert spacer subassembly see instruction on next page for insertion of spacer using gagging screws & tighten hub bolts to torque specified in drawing/catalogue.
6. A well aligned coupling will have neat straight disc packs.

Series 80L/80LSPL/80LSP/80LQ

1. Disassemble coupling by removing bolts. Remove gagging bolts/bushes (painted red) if fitted for protection of disc packs during shipment.
2. For pilot bored hubs do finish boring keeping Flange OD & Face true. Hub should be cleaned – burrs to be removed. Mount hubs. The hub should not be hammered on the shaft or spot heated. If necessary the hub may be heated in oil up to temperature 200 deg C to facilitate fitment.
3. Align driving & driven hubs as per general alignment instruction.
4. Fit Disc Packs & spacer & tighten bolts to torque specified in drawing/catalogue.
5. A well aligned coupling will have neat straight disc packs.

Series 80CC

1. Disassemble coupling by removing bolts.
2. Mount hub. The hub should not be hammered on the shaft or spot heated. If necessary the hub may be heated in oil up to temperature 200 deg C to facilitate fitment. Fit disc packs & spacer reel on respective shafts. Tighten disc pack bolts to torque specified in drawing/catalogue.
3. Bring driving & driven side close together.
4. Check alignment as per general alignment instruction and tighten spacer bolts.
5. A well aligned coupling will have neat straight disc packs.

Series 80CCS

1. Disassemble coupling by removing bolts.
2. Mount respective hubs on respective shafts. The hub should not be hammered on the shaft or spot heated. If necessary the hub may be heated in oil up to temperature 200 deg C to facilitate fitment.
3. Fit Disc pack & spacer plates. Tighten bolts to torque as per Drawing/catalogue
4. Check distance between shaft ends and align as per general alignment instructions.
5. Fit spacer piece (in two halves) and tighten bolts
6. A well aligned coupling will have neat straight disc packs.

Installation of Floating Shaft Series 80 Type SN , SV & SF

For special multi span application – request for Installation Manual from ‘Unique’.

1. Disassemble coupling at ends.
2. Clean shaft & bore. Mount hubs on Motor shaft /driven shaft. If required hub may be heated in oil up to 200 Deg C. Do not hammer or spot heat.
3. Measure Disc pack thickness inclusive of washers.
4. Bring equipment into best visual alignment. Check distance between shaft ends. Ensure pillow block is lubricated.
5. The gap between flanges should be equal to disc pack thickness inclusive of washers. Check this gap. Variation in gap should be + - 10 % of permissible end float.
6. If necessary shift pillow block/motor to ensure gap between flanges is within permissible limits.
7. A well aligned shaft will have neat straight disc packs.
8. Tighten all bolts/nuts to torque given in catalogue & drawing.
9. After several hours of initial running all nuts should be retightened and alignment rechecked and corrected if necessary.

Type DBZ,DBZ-A,DBZ-B,DBZ-C , Series AMR,CMR , Series 52,52SPL,52SP couplings

Installation is similar to Series 80L couplings. However these have disc packs with loose shims (i.e shims are not riveted together) . Washers are also loose. While disassembling and assembling care should be taken to fit in same order. The discs should be tied together. Care should be taken to ensure washers with chamfered side facing discs. Coupling should be aligned as per general alignment instructions.

Series 54 Couplings

Installation is similar to series 80CC. However series 54 has disc packs with loose shims & washers. While disassembling and assembling care is to be taken to fit in same order. Discs should be tied together. Washers with chamfered side should face discs. Coupling should be aligned as per general alignment instructions.



Riddhi Engineering Company

www.couplings-mounts.com

sales@riddhiengineeringco.com

+91 74900 32784