

Sure-Flex Plus® Elastomeric Couplings

F1



- **30% Higher Rating**
- **Quick, Easy Installation**
- **Clean, Quiet Performance**
- **No Lubrication, No Maintenance**

Table of Contents

Sure-Flex Plus® Table of Contents

Selection Guide	3-7
Components	3
Sleeve Selection	4
Sleeve Dimensions	5
Load/Service Factor	6
Coupling Ratings	7
Type J BTS Couplings	9
Type S BTS Couplings	10-11
Type B QD Bushed Couplings	11
Type SC BTS Spacer Couplings	12-15
Type C Clamp Hub Couplings	16
Installation Instructions	17

Sure-Flex Plus couplings are a TB Wood's original!



Sure-Flex Plus couplings utilize EPDM, Neoprene, and Hytrel™ flexible elastomer sleeves to transmit torque and accommodate shaft misalignment. Sure-Flex Plus couplings have exceptional torsional flexibility, with the 4-way flexing action absorbing virtually all types of shock, vibration, misalignment and end float. Sure-Flex Plus couplings are an excellent choice when low cost, high flexibility, low vibration and easy installation are important.

New! Sure-Flex® PLUS+

For over 50 years, TB Wood's has led the coupling industry with the original TB Wood's Sure-Flex design. And we haven't stopped innovating: this industry favorite just got even better. Our new Sure-Flex Plus EPDM and Neoprene sleeves are best-in-class for coupling performance and value. Here's why:

High Torque Rating

- **30% Increased Torque Rating**

Sure-Flex Plus sleeves provide longer service life in demanding applications, reducing required maintenance and associated replacement cost.

Longer Life

- **Sure-Flex Plus Lasts Over 3X Longer than the Competition**

Extensive testing shows our sleeves outlast the imitators. More uptime means less costly downtime.

Better Value

- **Save Money Using a Smaller Coupling**

Over 50% of common applications can now use a smaller coupling, lowering the cost of both coupling purchase and sleeve replacement.

Interchangeable

- **Retrofits to Existing Flanges**

No need to replace the full coupling – the Sure-Flex Plus sleeve design is 100% compatible with the current industry standard created by TB Wood's over 50 years ago.

Easy, Quick Installation

Sure-Flex Plus can be installed quickly and easily, thanks to its simple design with no bolts, gaskets, covers or seals. Alignment can be checked on the precision-machined flanges using only a straightedge and calipers. No special tools are needed for installation, alignment or removal.



Features

- Up to 72,480 in.lbs.; 8.20 kNm
- Quick and easy installation
- Spacer, bushed hub, and clamping hub designs in stock
- Flexible design accommodates misalignment and protects equipment
- 7° to 21° torsional wind up
- Needs no lubrication, no maintenance

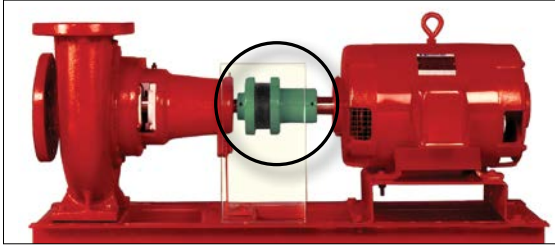

No Lubrication, Trouble-Free Operation

The teeth of the sleeve lock into the teeth of the flanges without clamps or screws, tightening under torque to provide smooth transmission of power. Couplings are not affected by abrasives, dirt or moisture, eliminating the need for lubrication or maintenance and providing clean, dependable, quiet performance.

Applications

Sure-Flex Plus couplings can be found hard at work in many industries. These couplings are ideal for a wide variety of applications including:

- Pumps
- Fans/Blowers
- Compressors
- Mixers
- Electric Motors
- Conveyors



Sure-Flex Plus 4-Way flexing action absorbs all types of shock, vibration and misalignment



Torsional

Sure-Flex Plus coupling sleeves have an exceptional ability to absorb torsional shock and dampen torsional vibrations. The EPDM and Neoprene sleeves wind up approximately 21° torsionally at their rated torque. Hytrel sleeves will wind up about 7°.

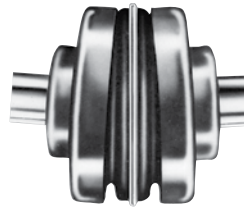

Angular

The unique design of the Sure-Flex Plus coupling's teeth allows for the absorption of angular misalignment without wear. Refer to page F1-18 for misalignment limits. Angular alignment can be achieved using only a scale and calipers.

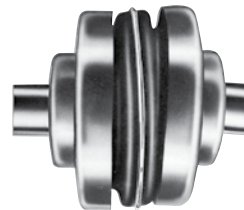

Parallel

Parallel misalignment is absorbed without wear or appreciable energy loss. The lateral flexibility of the coupling sleeve minimizes radial bearing loads normally associated with parallel misalignment. This feature also allows for easier installation by the use of components bored for slip fits without fretting corrosion occurring at the shaft. Refer to page F1-18 for parallel misalignment limits. Only a straight-edge and feeler gage are required for parallel alignment.

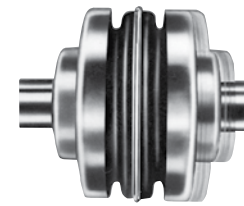

Axial

Sure-Flex Plus couplings may be used in applications with limited axial shaft movements. The axial compressibility of the EPDM and Neoprene sleeves allows for shaft end-float without the absolute transfer of thrust loads.

Sure-Flex Plus SELECTION GUIDE

Use the Coupling Selector Program on www.TBWoods.com/Select

Or follow these steps:

Sure-Flex Plus couplings are selected as component parts.

1. Determine SLEEVE material and type.
Refer to pages F1—4 & 5
2. Determine coupling SIZE.
Refer to pages F1—6, 7, & 8
3. Determine FLANGES to be used.
Refer to pages F1—9 thru 16

Specify coupling components.

- Example #1 - Close coupled
Size 6, Type S flange w 1-3/8 bore
Size 6, Type S flange w 1" bore
Size 6, Split EPDM sleeve
- Example #2 - 5" Between shaft spacer
Size 9, Type SC flange for #11 hub
Size 9, Type SC flange for #9 hub
Size 11 Hub w 2-3/8 bore
Size 9 Short hub w 1-1/8 bore
Size 9 Solid Hytrel sleeve

PROD. NUMBER	PROD. DESCRIPTION
6S138	6Sx1-3/8
6S1	6Sx1
6JS	6JES
9SC5011	9SC50-11
9SC50	9SC50
11SCH238	11SCH x 2-3/8
9SCHS118	9SCHS x 1-1/8
9H	9H

Sure-Flex Plus® Sleeve

Selection

Sure-Flex Plus Sleeves are available in three materials and various shape configurations.

New! Sure-Flex Plus EPDM and Neoprene sleeves have a 30% higher torque capacity.

	EPDM	Neoprene	Hytrel
CONSTRUCTIONS AVAILABLE			
1 pc, unsplit	JE	JN	H
1 pc, split	JES	JNS	-
2 pc, E/N w/ring	E	N	HS
TYPICAL USE	General Purpose	Oil Resist Non-flame	General Purpose
REL. RATING	1X	1X	3X
WIND-UP ANGULAR	21°	21°	7°
MISALIGN	1°	1°	1/4°
TEMPERATURE			
maximum	+275°F/+135°C	+200°F/+93°C	+250°F/+121°C
minimum	-30°F/-34°C	-0°F/-18°C	-65°F/-54°C

SURE-FLEX PLUS SLEEVES

Part No.	Product Description
3J	3JE EPDM
4J	4JE EPDM
5J	5JE EPDM
6J	6JE EPDM
7J	7JE EPDM
8J	8JE EPDM
9J	9JE EPDM
10J	10JE EPDM
3JS	3JES EPDM Split
4JS	4JES EPDM Split
5JS	5JES EPDM Split
6JS	6JES EPDM Split
7JS	7JES EPDM Split
8JS	8JES EPDM Split
9JS	9JES EPDM Split
10JS	10JES EPDM Split
3JN	3JN Neoprene
4JN	4JN Neoprene
5JN	5JN Neoprene
6JN	6JN Neoprene
7JN	7JN Neoprene
8JN	8JN Neoprene
3JNS	3JNS Neoprene Split
4JNS	4JNS Neoprene Split
5JNS	5JNS Neoprene Split
6JNS	6JNS Neoprene Split
7JNS	7JNS Neoprene Split
8JNS	8JNS Neoprene Split

Part No.	Product Description
4	4E EPDM
5	5E EPDM
6	6E EPDM
7	7E EPDM
8	8E EPDM
9	9E EPDM
10	10E EPDM
11	11E EPDM
12	12E EPDM
13	13E EPDM
14	14E EPDM
16	16E EPDM
4N	4N Neoprene
5N	5N Neoprene
6N	6N Neoprene
7N	7N Neoprene
8N	8N Neoprene
9N	9N Neoprene
10N	10N Neoprene
11N	11N Neoprene
12N	12N Neoprene
13N	13N Neoprene
14N	14N Neoprene

Part No.	Product Description
6H	6H Hytrel
7H	7H Hytrel
8H	8H Hytrel
9H	9H Hytrel
10H	10H Hytrel
11H	11H Hytrel
12H	12H Hytrel
6HS	6HS Split Hytrel
7HS	7HS Split Hytrel
8HS	8HS Split Hytrel
9HS	9HS Split Hytrel
10HS	10HS Split Hytrel
11HS	11HS Split Hytrel
12HS	12HS Split Hytrel
13HS	13HS Split Hytrel
14HS	14HS Split Hytrel

Selection

Flexible sleeves for Wood's Sure-Flex Plus couplings are available in three materials (EPDM, Neoprene, and Hytrel) and in three basic constructions. Characteristics of the materials are given on page F1—4 and the various types are shown and described here.



JE, JN

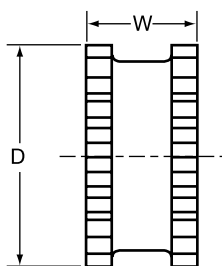

Types JES, JNS

JE-JES-JN-JNS

J sleeves are molded EPDM rubber (E) or Neoprene (N). They are available in one-piece solid construction (JE, JN) or one-piece split construction (JES, JNS). These sleeves may be used in any Sure-Flex Plus flange within a given size.



E and N
(Assembled)

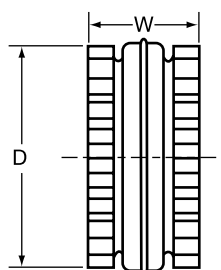

Types E and N
(Disassembled)

E-N

These sleeves are of two-piece design with a retaining ring. They are available in either EPDM (E) or Neoprene (N). They may be used with any flange within a given size. Sleeves are shown here assembled and disassembled.



H

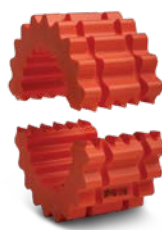
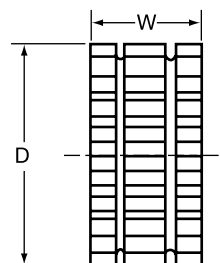

HS

H-HS

H (Hytrel) sleeves, designed for high-torque applications, transmit four times as much power as an equivalent EPDM or Neoprene sleeve. Available in one-piece solid construction (H) or two-piece split construction (HS), these can be used only with S, C and SC flanges. They cannot be used with J or B flanges or as direct replacements for EPDM or Neoprene sleeves.

DIMENSIONS (in.)

Coupling Size	JE, JES, JN & JNS Sleeves EPDM & Neoprene			E and N Sleeves EPDM & Neoprene			H & HS Sleeves Hytrel		
	D	W	Weight (lbs.)	D	W	Weight (lbs.)	D	W	Weight (lbs.)
3	1-7/8	1	.06						
4	2-5/16	1-1/4	.10	2-5/16	1-1/4	.11			
5	2-15/16	1-9/16	.20	2-15/16	1-9/16	.25			
6	3-3/4	1-7/8	.40	3-3/4	1-7/8	.49	3-3/4	1-7/8	.44
7	4-11/32	2-3/16	.62	4-11/32	2-3/16	.77	4-11/32	2-3/16	.69
8	5-1/16	2-1/2	1.13	5-1/16	2-1/2	1.4	5-1/16	2-1/2	1.4
9*	6	3	1.46	6	3	2.0	6	3	1.8
10*	7-1/16	3-7/16	2.32	7-1/16	3-7/16	3.2	7-1/16	3-7/16	2.9
11				8-3/16	4	5.1	8-3/16	4	4.5
12				9-9/16	4-11/16	8.1	9-9/16	4-11/16	7.3
13				11-3/16	5-1/2	13.0	11-3/16	5-1/2	11.8
14				13-3/32	6-1/2	21.1	13-3/32	6-1/2	19.3
16				17-29/32	8-3/4	45.3			

Sizes 13 and 14 Hytrel available with HS sleeves only.

*All 9J and 10J sleeves available in EPDM only.

Sure-Flex Plus® Coupling

Selection

A. Select Load Symbol based on your driven machine.

Application	Load Symbol	Application	Load Symbol	Application	Load Symbol
AGITATORS—Paddle, Propeller, Screw	L	DEWATERING SCREEN (sewage)	M	MILLS	
BAND RESAW (lumber)	M	DISC FEEDER	L	Ball, Pebble, Rod, Tube, Rubber Tumbling . . .H	
BARGE HAUL PULLER	H	DOUGH MIXER	M	Dryer and Cooler	M
BARKING (lumber)	H	DRAW BENCH CONVEYOR and MAIN DRIVE	H	MIXERS	
BAR SCREEN (sewage)	L	DREDGES		Concrete, Muller	M
BATCHES (textile)	L	Cable Reel, Pumps	M	Banbury	H
BEATER AND PULPER (paper)	M	Cutter Head Drive, Jig Drive, Screen Drive . .H		ORE CRUSHER	H
BENDING ROLL (metal)	M	Maneuvering and Utility Winch, Stacker . . .M		OVEN CONVEYOR	L
BLEACHER (paper)	L	DYNAMOMETER	L	PLANER (metal or wood)	M
BLOWERS		DRYERS (rotary)	M	PRESSES	
Centrifugal, Vane	L	EDGER (lumber)	H	Brick, Briquette Machine	H
Lobe	M	ELEVATOR		Notching, Paper, Punch, Printing	M
BOTTLING MACHINERY	L	Bucket	M	PUG MILL	M
BREW KETTLES (distilling)	L	Escalator	L	PULP GRINDER (paper)	H
BUCKET ELEVATOR OR CONVEYOR	M	Freight, Passenger, Service, Man LiftH		PULVERIZERS	
CALENDERS		ESCALATORS	L	Hammermill—light duty, Roller	M
Calendar (paper)	M	EXTRUDER (metal)	H	Hammermill—heavy duty, Hog	H
Calendar-super (paper), Calender (rubber) . .H		FANS		PUMPS	
CANE KNIVES (sugar)	M	Centrifugal	L	Centrifugal, Axial	L
CARD MACHINE (textile)	H	Cooling Tower	H	Gear, Lobe, Screw, Vane	M
CAR DUMPERS	H	Forced Draft, Large Industrial or MineM		Reciprocating—sgl. or dbl. acting, cylinder	*
CAR PULLERS	M	FEEDERS		REEL, REWINDER (paper) CABLE	M
CEMENT KILN	H	Apron, Belt, Disc	L	ROD MILL	H
CENTRIFUGAL EQUIPMENT		Reciprocating	H	SAWDUST CONVEYOR	L
Blowers, Compressors, Fans, PumpsL		Screw	M	SCREENS	
CHEMICAL FEEDERS (sewage)	L	FILTER, PRESS-OIL	M	Air Washing, Water	L
CHILLER (oil)	M	GENERATORS		Rotary for coal or sand	M
CHIPPER (paper)	H	Uniform load	L	Vibrating	H
CIRCULAR RESAW (lumber)	M	Varying load, Hoist	M	SCREW CONVEYOR	L
CLARIFIER or CLASSIFIER	L	Welders	H	SLAB CONVEYOR (lumber)	M
CLAY WORKING MACHINERY	M	GRIT COLLECTOR (sewage)	L	SLITTERS (metal)	M
COLLECTORS (sewage)	L	GRIZZLY	H	SOAPERS (textile)	L
COMPRESSORS		HAMMERMILL		SORTING TABLE (lumber)	M
Centrifugal, Gear, Lobe, Screw	L	Light Duty, Intermittent	M	SPINNER (textile)	M
Reciprocating	*	Heavy Duty, Continuous	H	STOKER	L
CONCRETE MIXERS	M	HOISTS		SUCTION ROLL (paper)	M
CONVERTING MACHINE (paper)	M	Heavy Duty	H	TENTER FRAMES (textile)	M
CONVEYORS		Medium Duty	M	TIRE BUILDING MACHINES	H
Apron, Assembly Belt, Flight, Oven, Screw . .L		JORDAN (paper)	H	TIRE & TUBE PRESS OPENER	L
Bucket	M	KILN, ROTARY	H	TUMBLING BARRELS	H
COOKERS—Brewing, Distilling, FoodL		LAUNDRY WASHER or TUMBLER	H	WASHER and THICKENER (paper)	M
COOLING TOWER FANS	H	LINE SHAFTS	L	WINCHES	M
COUCH (paper)	M	LOG HAUL (lumber)	H	WINDERS, Paper, Textile, Wire	M
CRANES and HOISTS	M	LOOM (textile)	M	WINDLASS	M
Heavy Duty Mine	H	MACHINE TOOLS, MAIN DRIVE	M	WIRE	
CRUSHERS—Cane (sugar), Stone or OreH		MANGLE (textile)	L	Drawing	H
CUTTER—Paper	H	MASH TUBS (distilling)	L	Winding	M
CYLINDER (paper)	H	MEAT GRINDER	M	WOODWORKING MACHINERY	L
		METAL FORMING MACHINES	M		

*Consult Factory

B. Determine Service Factor using Load Symbol and driver.

Load Symbol	L Light	M Medium	H Heavy
Standard AC Motor			
DC Shunt Motor	1.25	1.5	2.0
Engine, 8 or more cylinders			
High Torque AC Motor			
DC Series & Comp.	1.5	2.0	2.5
Engine, 4-6 cylinders			
Engine, 3 cylinders or less	2.0	2.5	3.0
Turbine	1.0	1.25	1.5

On applications involving varying torque loads, design around the maximum load. Then determine the resulting service factor at minimum load. If this value is greater than 5.2 for EPDM or Neoprene sleeves, or 4.0 for Hytrel sleeves, special coupling alignment will be required (see page F1—18).

Caution: Applications involving reciprocating engines and reciprocating driven devices are subject to rotational vibrational critical speeds which may destroy the coupling.

C. Determine Size using Coupling Rating Tables

- For 860, 1160, 1750 or 3500 RPM, use table on page F1-8.
- For other speeds, find the coupling size by calculating HP rating @100 RPM:

$$HP @ 100 \text{ RPM} = HP \times \text{Service Factor} \times 100 / \text{coupling RPM}$$

In the table below, choose a coupling with a HP@100 rating greater than calculated above.

Example:

For 4 HP @ 55 RPM and 1.25 Service Factor:

$$HP @ 100 = 4 \times 1.25 \times 100 / 55 = 9.1$$

Use #11 EPDM or Neoprene or #9 Hytrel

Do not exceed a 5.2 Service Factor for EPDM or Neoprene sleeves, or 4.0 for Hytrel sleeves.

Online Selection Tools

Coupling selection program, 3-D CAD models, e-catalog, and interchange guide make selecting the right coupling simple!

www.TBWoods.com/Couplings

New! Sure-Flex Plus EPDM and Neoprene sleeves have a 30% higher torque capacity.

COUPLING RATINGS

Size	EPDM Sleeves	Neoprene Sleeves	HP @ RPM				Torque (in. lbs.)	Stiffness (in. lbs./rad)	Max RPM
			100	1160	1750	3500			
3	JE,JES	JN,JNS	0.1	1.4	2.2	4.3	78	229	9200
4	E,JE,JES	N,JN,JNS	0.2	2.9	4.3	8.7	156	458	7600
5	E,JE,JES	N,JN,JNS	0.5	5.7	8.7	17	312	916	7600
6	E,JE,JES	N,JN,JNS	0.9	11	16	32	585	1718	6000
7	E,JE,JES	N,JN,JNS	1.5	17	26	52	940	2769	5250
8	E,JE,JES	N,JN,JNS	2.3	27	41	82	1475	4335	4500
9	E,JE,JES	N	3.7	43	65	130	2340	6875	3750
10	E,JE,JES	N	5.9	69	104	208	3735	10980	3600
11	E	N	9.3	108	164	327	5890	17300	3600
12	E	N	15	172	260	-	9360	27500	2800
13	E	N	23	272	410	-	14750	43350	2400
14	E	N	37	431	650	-	23400	68755	2200
16	E	-	75	870	-	-	47250	180480	1500
Size	Hytrel Sleeves	HP @ RPM				Torque (in. lbs.)	Stiffness (in. lbs./rad)	Max RPM	
		100	1160	1750	3500				
6	H, HS	2.9	33	50	100	1800	10000	6000	
7	H, HS	4.6	53	80	160	2875	20000	5250	
8	H, HS	7.2	84	126	252	4530	30000	4500	
9	H, HS	11	132	200	400	7200	47500	3750	
10	H, HS	18	209	315	630	11350	100000*	3600	
11	H, HS	29	331	500	1000	18000	125000*	3600	
12	H, HS	50	580	875		31500	225000*	2800	
13	HS	75	870	1312		47268	368900	2400	
14	HS	115	1334	2013		72480	593250	2200	

Sure-Flex Plus® Coupling

Selection

EPDM or NEOPRENE SLEEVES

860 RPM MOTORS						1160 RPM MOTORS						1750 RPM MOTORS						3500 RPM MOTORS						
HP	Service Factors					HP	Service Factors					HP	Service Factors					HP	Service Factors					
	1.0	1.25	1.5	2.0	2.5		1.0	1.25	1.5	2.0	2.5		1.0	1.25	1.5	2.0	2.5		1.0	1.25	1.5	2.0	2.5	
0.5	3	3	3	3	4	0.5	3	3	3	3	3	0.5	3	3	3	3	3	0.5	3	3	3	3	3	
0.75	3	3	3	3	4	0.75	3	3	3	3	4	0.75	3	3	3	3	3	0.75	3	3	3	3	3	
1	3	4	4	4	5	1	3	3	4	4	4	1	3	3	3	3	4	1	3	3	3	3	3	
1.5	4	4	5	5	5	1.5	4	4	4	5	5	1.5	3	3	4	4	4	1.5	3	3	3	3	3	
2	4	5	5	5	6	2	4	4	5	5	5	2	3	4	4	4	5	2	3	3	3	3	4	
3	5	5	6	6	6	3	5	5	5	6	6	3	4	4	5	5	5	3	3	3	4	4	4	
5	6	6	6	7	7	5	5	6	6	6	7	5	5	5	5	6	6	5	4	4	4	4	5	5
7.5	6	7	7	8	8	7.5	6	6	7	7	8	7.5	5	6	6	6	7	7.5	4	5	5	5	6	6
10	7	7	8	8	9	10	6	7	7	8	8	10	6	6	6	7	7	10	5	5	5	6	6	6
15	8	8	9	9	10	15	7	8	8	9	9	15	6	7	7	8	8	15	5	6	6	6	7	7
20	8	9	9	10	10	20	8	8	9	9	10	20	7	7	8	8	9	20	6	6	6	7	7	7
25	9	9	10	10	11	25	8	9	9	10	10	25	7	8	8	9	9	25	6	6	7	7	8	8
30	9	10	10	11	11	30	9	9	10	10	11	30	8	8	9	9	10	30	6	7	7	8	8	8
40	10	10	11	11	12	40	9	10	10	11	11	40	8	9	9	10	10	40	7	7	8	8	9	9
50	10	11	11	12	12	50	10	10	11	11	12	50	9	9	10	10	11	50	7	8	8	9	9	9
60	11	11	12	12	13	60	10	11	11	12	12	60	9	10	10	11	11	60	8	8	9	9	10	10
75	11	12	12	13	13	75	11	11	12	12	13	75	10	10	11	11	12	75	8	9	9	10	10	10
100	12	12	13	13	14	100	11	12	12	13	13	100	10	11	11	12	12	100	9	9	10	10	11	11
125	12	13	13	14	14	125	12	12	13	13	14	125	11	11	12	12	13	125	9	10	10	11	11	11
150	13	13	14	14	16	150	12	13	13	14	14	150	11	12	12	13	13	150	10	10	11	11	-	-
200	13	14	14	16	16	200	13	13	14	14	16	200	12	12	13	13	14	200	10	11	11	-	-	-
250	14	14	16	16	16	250	13	14	14	16	16	250	12	13	13	14	14	250	11	11	-	-	-	-
300	14	16	16	16	16	300	14	14	16	16	16	300	13	13	14	14		300	11	-	-	-	-	-
350	16	16	16	16	-	350	14	16	16	16	16	350	13	14	14	-	-	350	-	-	-	-	-	-
400	16	16	16	-	-	400	14	16	16	16	16	400	13	14	14	-	-	400	-	-	-	-	-	-
450	16	16	-	-	-	450	16	16	-	-	-	450	14	-	-	-	-	450	-	-	-	-	-	-
500	16	16	-	-	-	500	16	16	-	-	-	500	14	-	-	-	-	500	-	-	-	-	-	-
600	16	-	-	-	-	600	16	-	-	-	-	600	-	-	-	-	-	600	-	-	-	-	-	-
700	-	-	-	-	-	700	-	-	-	-	-	700	-	-	-	-	-	700	-	-	-	-	-	-
800	-	-	-	-	-	800	-	-	-	-	-	800	-	-	-	-	-	800	-	-	-	-	-	-

HYTREL SLEEVES

860 RPM MOTORS						1160 RPM MOTORS						1750 RPM MOTORS						3500 RPM MOTORS						
HP	Service Factors					HP	Service Factors					HP	Service Factors					HP	Service Factors					
	1.0	1.25	1.5	2.0	2.5		1.0	1.25	1.5	2.0	2.5		1.0	1.25	1.5	2.0	2.5		1.0	1.25	1.5	2.0	2.5	
7-1/2	6	6	6	6	6	7-1/2	-	-	-	-	-	7-1/2	-	-	-	-	-	7-1/2	-	-	-	-	-	-
10	6	6	6	6	6	10	6	6	6	6	6	10	-	-	-	-	-	10	-	-	-	-	-	-
15	6	6	6	7	7	15	6	6	6	6	7	15	6	6	6	6	6	15	-	-	-	-	-	-
20	6	6	7	7	8	20	6	6	6	7	7	20	6	6	6	6	6	20	-	-	-	-	-	-
25	6	7	7	8	8	25	6	6	7	7	8	25	6	6	6	6	7	25	-	-	-	-	-	-
30	7	7	8	8	9	30	6	7	7	8	8	30	6	6	6	7	7	30	6	6	6	6	6	6
40	7	8	8	9	9	40	7	7	8	8	9	40	6	6	7	7	8	40	6	6	6	6	6	6
50	8	8	9	9	10	50	7	8	8	9	9	50	6	7	7	8	8	50	6	6	6	6	6	7
60	8	9	9	10	10	60	8	8	9	9	10	60	7	7	8	8	9	60	6	6	6	6	7	7
75	9	9	10	10	11	75	8	9	9	10	10	75	7	8	8	9	9	75	6	6	7	7	8	8
100	9	10	10	11	11	100	9	9	10	10	11	100	8	8	9	9	10	100	6	7	7	8	8	8
125	10	10	11	11	12	125	9	10	10	11	11	125	8	9	9	10	10	125	7	7	8	8	9	9
150	10	11	11	12	12	150	10	10	11	11	12	150	9	9	10	10	11	150	7	8	8	9	9	9
200	11	11	12	12	13	200	10	11	11	12	12	200	9	10	10	11	11	200	8	8	9	9	10	10
250	11	12	12	13	13	250	11	11	12	12	13	250	10	10	11	11	12	250	8	9	9	10	10	10
300	12	12	13	13	14	300	11	12	12	13	13	300	10	11	11	12	12	300	9	9	10	10	11	11
350	12	12	13	14	14	350	12	12	12	13	14	350	11	11	12	12	12	350	9	10	10	11	11	11
400	12	13	13	14	14	400	12	12	13	13	14	400	11	11	12	12	13	400	9	10	10	11	11	11
500	13	13	14	14	-	500	12	13	13	14	14	500	11	12	12	13	13	500	10	10	11	11	-	-
600	13	14	14	-	-	600	13	13	13	14	-	600	12	12	13	13	14	600	10	11	11	-	-	-
700	14	14	-	-	-	700	13	13	14	14	-	700	12	12	13	14	14	700	11	11	-	-	-	-
800	14	14	-	-	-	800	13	14	14	-	-	800	12	13	13	14	14	800	11	11	-	-	-	-
900	14	-	-	-	-	900	14	14	14	-	-	900	13	13	14	14	-	900	11	-	-	-	-	-
1000	-	-	-	-	-	1000	14	14	-	-	-	1000	13	13	14	14	-	1000	11	-	-	-	-	-

NOTE: Flange Bore capacity should be verified for selected coupling based on equipment shaft size

Selection For Close Coupled Applications

FLANGES

Type J flanges sizes 3, 4 and 5 are manufactured of sintered carbon steel. The powdered metal manufacturing process provides high dimensional accuracy and uniform material properties for high strength. Size 6 is made of high strength cast iron.

Flanges are bored-to-size for a slip fit on standard shafts. The outside face of the flange is precision machined, allowing the surface to be used to align the coupling without special tools.

Type J flanges can be used with EPDM and Neoprene sleeves. Each flange has a standard keyway, one setscrew over the keyway and one setscrew at 90° from the keyway.

COUPLINGS

Spacing between internal flange hubs equals G. Spacing between shafts should be greater than 1/8 in. and less than L minus .85 times the sum of the two bore diameters.

To order couplings, refer to the part number examples on page F1-3. When specifying Type J flanges, the coupling and bore sizes accompany the flange symbol "J". For example, 3J x 1/2 is 3J12.

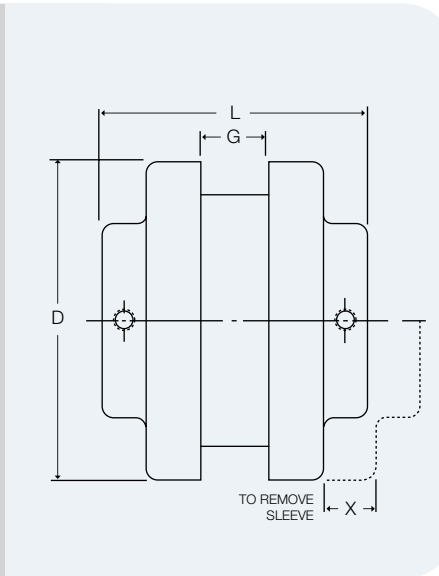
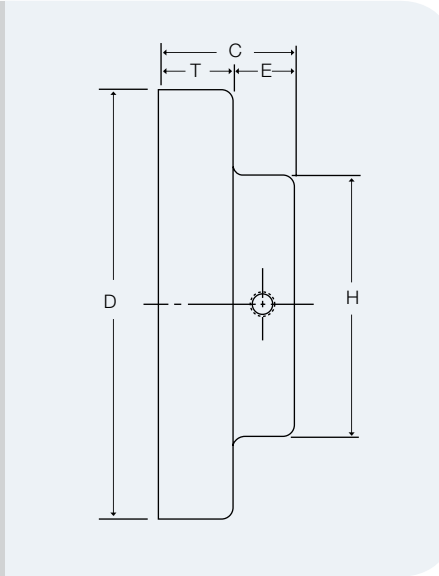

DIMENSIONS (in.)

Size	Dimensions									Wt. (lbs.)	STOCK BORES*																				
											Inches										Max Bore	Millimeters									
	C	D	E	G	H	L	T	X	3/8		1/2	5/8	3/4	7/8	15/16	1	1-1/8	1-3/16	1-1/4	1-3/8		9	11	12	14	15	16	19	20	24	25
3J	51/64	2.062	13/32	3/8	1-1/2	1-31/32	25/64	5/8	0.3	X	X	X	X	X							7/8	-	X	X	X	X	X	X	-	-	-
4J	55/64	2.500	27/64	43/64	1-5/8	2-25/64	7/16	5/8	0.4		X	X	X	X	X	X					1	-	-	-	X	X	X	X	X	X	X
5J	1-3/64	3.250	29/64	3/4	1-7/8	2-27/32	19/32	59/64	0.9		X	X	X	X	X	X	X				1-1/8	-	-	-	-	-	-	-	-	-	-
6J	1-5/16	4.000	9/16	7/8	2-1/2	3-1/2	3/4	1-3/32	1.2			X	X	X	X	X	X	X	X	X	1-3/8	-	-	-	-	-	-	-	-	-	-

■ Approximate weight for each flange.

* See page F1-10 for bore tolerances and page F1-13 for standard keyway dimensions.

Type S Sure-Flex Plus® BTS

Selection For Close Coupled Applications

COUPLINGS

Spacing between shafts should be greater than 1/8 in. and less than L minus .85 times the sum of the two bore diameters. Spacing between internal flange hubs equals $L - 2*C$.

To order couplings, refer to the part number examples on page F1-3.

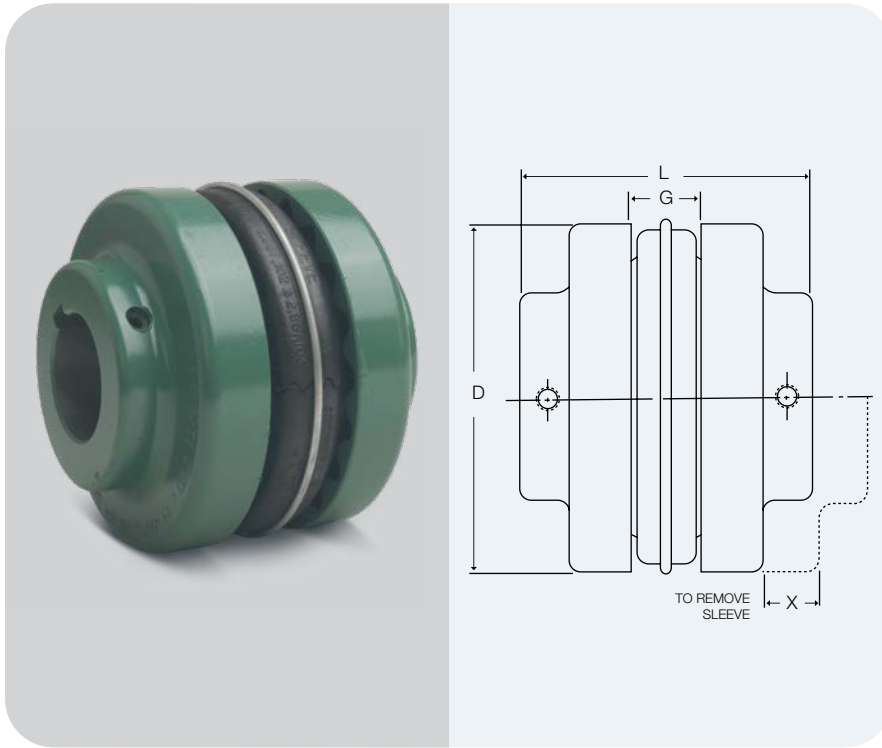

DIMENSIONS (in.)

STOCK BORES																				Max Bore		SHALLOW KEYSEAT DIMENSIONS ②																											
Millimeters																				①	②	Bore	K.S.	Key	Bore	K.S.	Key	Bore	K.S.	Key																			
14	15	16	19	20	24	25	28	30	32	35	38	42	45	48	50	52	55	60	65	70	80	90	Standard Keyseat	Shallow Keyseat																									
X	X	X	X	X	X	X	X																	1-3/16	1-1/4	1-1/4	1/4 X 1/16	1/4 X 3/16 X 1-3/8	-	-	-	-	-	-	-	-													
	X		X	X	X	X	X	X	X	X															1-7/16	1-1/2 ④	-	-	-	-	-	-	-	-	-	-	-	-											
											X														-	1-3/4	1-1/2 & 1-5/8	3/8 X 1/8	3/8 x 5/16 X ③	1-3/4	3/8 X 1/16	3/8 X 1/4 X 1-1/4	-	-	-	-	-	1-7/8	1/2 X 1/16	1/2 X 5/16 X 1-9/16									
			X	X	X	X	X	X	X	X	X	X													1-5/8	1-7/8	1-7/8	1/2 X 1/8	1/2 X 3/8 X 1-7/8	-	-	-	-	-	-	-	-	-	-	-									
				X	X	X	X	X	X	X	X	X	X												1-15/16	2-1/4 ④	2-1/8	1/2 X 3/16	1/2 X 7/16 X 2-1/8	-	-	-	-	-	-	-	-	-	-	-									
																									-	2-3/8	-	-	-	2-3/8	5/8 X 1/8	5/8 X 7/16 X 1-7/8	-	-	-	-	-	-	-	-	-	-	-						
				X				X	X	X	X	X	X												2-1/2	2-3/4 ④	-	-	-	-	-	-	-	-	-	-	-	-	-	-	-	-	-	-					
																									-	2-7/8	2-7/8	3/4 X 1/8	3/4 X 1/2 X 2-1/4	-	-	-	-	-	-	-	-	-	-	-	-	-	-						
								X	X	X	X	X	X	X	X	X	X	X	X						2-3/4	3-1/8 ④	2-7/8	3/4 X 1/4	3/4 X 5/8 X 2-3/4	-	-	-	-	-	-	-	-	-	-	-	-	-	-	-	-				
																									-	3-3/8	3-3/8	-	-	3-3/8	7/8 X 3/16	7/8 X 5/8 X 2-5/8	-	-	-	-	-	-	-	-	-	-	-	-	-				
											X	X	X	X			X	X	X	X					3-3/8	3-7/16 ④	3-7/16	7/8 X 3/16	7/8 X 5/8 X 3-7/16	-	-	-	-	-	-	-	-	-	-	-	-	-	-	-	-				
																									-	3-7/8	3-7/8	3-7/8	1 X 1/4	1 X 3/4 X 3	-	-	-	-	-	-	-	-	-	-	-	-	-	-	-	-			
															X			X	X	X	X	X			3-7/8	3-15/16	-	-	-	-	-	-	-	-	-	-	-	-	-	-	-	-	-	-	-	-	-	-	
																									4-1/2	-	-	-	-	-	-	-	-	-	-	-	-	-	-	-	-	-	-	-	-	-	-	-	-
																									5	-	-	-	-	-	-	-	-	-	-	-	-	-	-	-	-	-	-	-	-	-	-	-	-
																									5-1/2	6	-	-	-	-	-	-	-	-	-	-	-	-	-	-	-	-	-	-	-	-	-	-	-

① See charts on page F1-13

② Some large bore Type S flanges are supplied with shallow keyseats. In these cases, a rectangular key is furnished. The bores involved are listed above.

③ 1-5/8 for 1-1/2 bore, 1-5/16 for 1-5/8 bore.

④ Altered bores available only up to this diameter.

Type B Sure-Flex Plus® QD Bushed

Selection For Close Coupled Applications

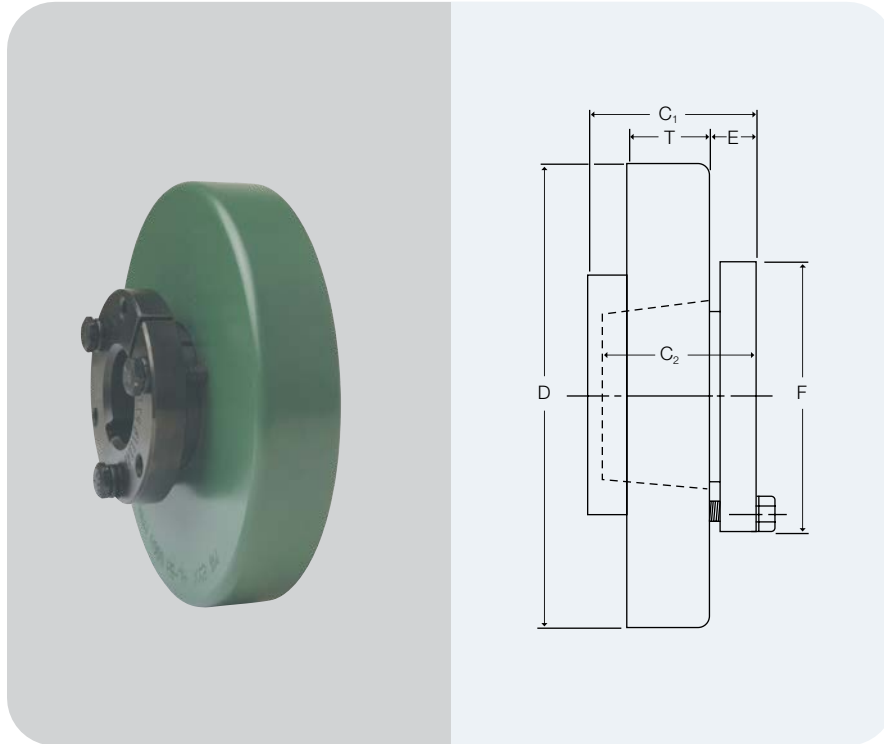

FLANGES

Type B flanges are made of high-strength cast iron and are designed to accommodate Wood's Sure-Grip Bushings for easy installation and removal.

BUSHINGS

Sure-Grip Bushings offer convenient mounting of the flange to the shaft securely without setscrews. They are tapered and are split through both the bushing flange and taper to provide a clamp fit, eliminating wobble, vibration and fretting corrosion. This is the same bushing used in Wood's sheaves and pulleys and is readily available everywhere.

Dimensions (in.)

Size	Bushing Required	Dimensions									Max Bore*	Weight (lbs.) ■	
		C ₁	C ₂	D	E	F	G	L	T	X		Flange	Bushing
6B	JA	1-7/32	1	4.000	15/32	2	7/8	3-3/8	25/32	1-3/32	1-1/4	1.4	.8
7B	JA	1-5/8	1	4.625	15/32	2	1	3-1/2	25/32	1-5/16	1-1/4	1.9	.8
8B	SH	1-29/32	1-1/4	5.450	9/16	2-11/16	1-1/8	4-1/16	29/32	1-1/2	1-5/8	2.9	1.0
9B	SD	2-1/4	1-13/16	6.350	5/8	3-3/16	1-7/16	4-3/4	1-1/32	1-3/4	1-15/16	4.8	1.5
10B	SK	1-15/16	1-7/8	7.500	23/32	3-7/8	1-5/8	5-1/2	1-7/32	2	2-1/2	7.8	2.0
11B	SF	2-3/16	2	8.625	11/16	4-5/8	1-7/8	6-1/4	1-1/2	2-3/8	2-15/16	12.0	3.5
12B	E	2-23/32	2-5/8	10.000	29/32	6	2-5/16	7-1/2	1-11/16	2-11/16	3-1/2	18.0	9.0
13B	F	3-3/4	3-5/8	11.750	1-1/16	6-5/8	2-11/16	8-3/4	1-31/32	3	3-15/16	31.2	14.0
14B	F	3-3/4	3-5/8	13.875	1-1/16	6-5/8	3-1/4	9-7/8	2-1/4	3-1/2	3-15/16	51.4	14.0
16B	J	4-13/16	4-1/2	18.875	1-1/4	7-1/4	4-3/4	12-3/4	2-3/4	4-1/4	4-1/2	120.0	22.0

* Maximum bore with keyseat.
 ■ Approximate weight for each flange.

Type B Sure-Flex Plus® QD Bushed

Selection For Close Coupled Applications

COUPLINGS

Type B Sure-Flex Plus Couplings can use EPDM or Neoprene sleeves. **Do not use Hytrel sleeves with Type B couplings.**

Spacing between internal flange hubs equals L minus 2 times C₂. Spacing between shafts should be greater than 1/8 in. and less than G.

To order complete couplings, specify coupling size with flange symbol (B) and bushing. Refer to page F1-3 to order the required coupling. Refer to charts below for bushings.

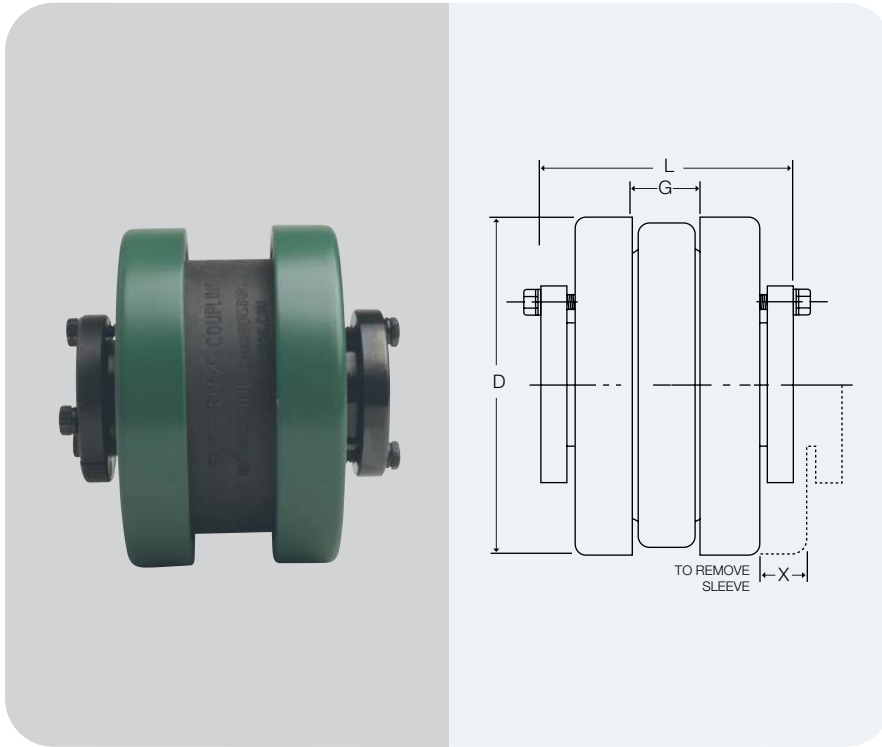

SURE-GRIP® BUSHING KEYSEAT DIMENSIONS (in.)

Bushing	Bores	Keyseat
JA	1/2 – 1	Standard ①
	1-1/16 – 1-3/16	1/4 x 1/16
	1-1/4	1/4 x 1/32
SH	1/2 – 1 3/8	Standard ①
	1-7/16 – 1 5/8	3/8 x 1/16
	1-11/16	No K.S.
SD	1/2 – 1-11/16	Standard ①
	1-3/4	3/8 x 1/8
	1-13/16	1/2 x 1/8
	1-7/8 – 1-15/16	1/2 x 1/16
SK	1/2 – 2-1/8	Standard ①
	2-3/16 – 2-1/4	1/2 x 1/8
	2-5/16 – 2 1/2	5/8 x 1/16
	2-9/16 – 2 5/8	No K.S.

Bushing	Bores	Keyseat
SF	1/2 – 2-1/4	Standard ①
	2-5/16 – 2-1/2	5/8 x 3/16
	2-9/16 – 2-3/4	5/8 x 1/16
	2-13/16 – 2-7/8	3/4 x 1/16
	2-15/16	3/4 x 1/32
E	7/8 – 2-7/8	Standard ①
	2-5/16 – 3-1/4	3/4 x 1/8
	3-5/16 – 3-1/2	7/8 x 1/16
F	1 – 3-1/4	Standard ①
	3-5/16 – 3-3/4	7/8 x 3/16
	3-13/16 – 3-15/16	1 x 1/8
	4	No K.S.
J	1-7/16 – 3-13/16	Standard ①
	3-7/8 – 3-15/16	1 x 3/8
	4 – 4-1/2	1 x 1/8

① Standard Keyseat Dimension

Shaft Dia.	Width	Depth
1/2 – 9/16	1/8	1/16
5/8 – 7/8	3/16	3/32
15/16 – 1-1/4	1/4	1/8
1-5/16 – 1-3/8	5/16	5/32
1-7/16 – 1-3/4	3/8	3/16
1-13/16 – 2-1/4	1/2	1/4
2-5/16 – 2-3/4	5/8	5/16
2-13/16 – 3-1/4	3/4	3/8
3-5/16 – 3-3/4	7/8	7/16
3-13/16 – 4-1/2	1	1/2
4-9/16 – 5-1/2	1-1/4	5/8
5-9/16 – 6-1/2	1-1/2	3/4



Selection Conventional Spacer Design

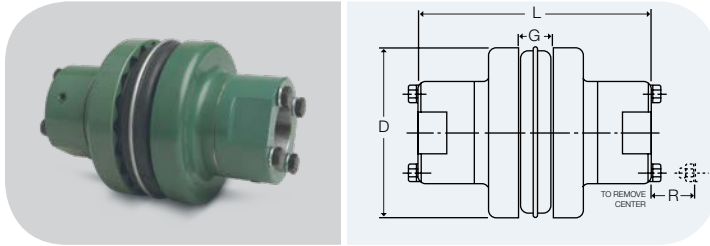

For other distances between shaft ends not shown here, please see page F1-16 or use the Coupling Selection Program at www.TBWoods.com/Select.

For dimensions of separate Type SC Spacer components, refer to page F1-15.

Coupling Size	Required Distance Between Shafts	Use Flange Number	Use Hub Number	Max Bore Std. KS	Dimensions				Weight (lbs.) ■
					D	L ⁽²⁾	G	R	
4JSC	3-1/2	4JSC35	-	1-1/8 ⁽¹⁾	2.460	5-5/8	5/8	-	2.7
5SC	3-1/2	5SC35	5SCH	1-1/8	3.250	5-5/8	3/4	9/16	4.5
6SC	3-1/2	6SC35	6SCH-6SCHS	1-3/8	4.000	5-7/8	7/8	3/4	7.3
	4-3/8	6SC44	6SCH-6SCHS	1-3/8	4.000	6-3/4	7/8	3/4	8.1
7SC	5	6SC50	6SCH-6SCHS	1-3/8	4.000	7-3/8	7/8	3/4	8.7
	3-1/2	7SC35	7SCH-7SCHS	1-5/8	4.625	6-3/8	1	5/8	9.9
	4-3/8	7SC44	7SCH-7SCHS	1-5/8	4.625	7-1/4	1	5/8	10.8
8SC	5	7SC50	7SCH-7SCHS	1-5/8	4.625	7-7/8	1	5/8	11.4
	3-1/2	8SC35	8SCH-8SCHS	1-7/8	5.450	6-7/8	1-1/8	13/16	15.2
	4-3/8	8SC44	8SCH-8SCHS	1-7/8	5.450	7-3/4	1-1/8	13/16	16.4
	5	8SC50	8SCH-8SCHS	1-7/8	5.450	8-3/8	1-1/8	1-3/16	17.4
9SC	5	8SC50-10	10SCH-10SCHS	2-3/8	5.450	9-5/8	1-1/8	1-3/16	27.2
	3-1/2	9SC35	9SCH-9SCHS	2-1/8	6.350	7-1/2	1-7/16	1-1/16	18.6
	4-3/8	9SC44	9SCH-9SCHS	2-1/8	6.350	8-1/4	1-7/16	1-1/16	22.2
	5	9SC50	9SCH-9SCHS	2-1/8	6.350	8-7/8	1-7/16	1-1/16	23.2
	7	9SC70-11	11SCH-11SCHS	2-7/8	6.350	10-3/8	1-7/16	1-3/16	40.4
10SC	7-3/4	9SC78-11	11SCH-11SCHS	2-7/8	6.350	13-1/8	1-7/16	1-3/16	51.0
	4-3/4	10SC48	10SCH-10SCHS	2-3/8	7.500	9-3/8	1-5/8	1-3/16	37.6
	5	10SC50	10SCH-10SCHS	2-3/8	7.500	9-5/8	1-5/8	1-3/16	38.4
	7	10SC70-13	13SCH-13SCHS	3-3/8	7.500	13-5/8	1-5/8	1-7/8	72.0
11SC	7-3/4	10SC78-13	13SCH-13SCHS	3-3/8	7.500	14-3/8	1-5/8	1-7/8	76.0
	10	10SC100-13	13SCH-13SCHS	3-3/8	7.500	16-5/8	1-5/8	1-7/8	88.0
	4-3/4	11SC48	11SCH-11SCHS	2-7/8	8.625	10-5/16	1-7/8	1-3/16	54.5
	5	11SC50	11SCH-11SCHS	2-7/8	8.625	10-3/8	1-7/8	1-3/16	54.7
	7	11SC70-14	14SCH	3-7/8	8.625	14-5/8	1-7/8	2	86.1
12SC	7-3/4	11SC78-14	14SCH	3-7/8	8.625	15-3/8	1-7/8	2	90.3
	10	11SC100-14	14SCH	3-7/8	8.625	17-5/8	1-7/8	2	102.7
	7	12SC70	12SCH-12SCHS	2-7/8	10.000	12-7/8	2-5/16	1-1/2	88.1
	7-3/4	12SC70-14	14SCH	3-7/8	10.000	14-5/8	2-5/16	2	99.1
	10	12SC78-14	14SCH	3-7/8	10.000	15-3/8	2-5/16	2	103.3
13SC	10	12SC100-14	14SCH	3-7/8	10.000	17-5/8	2-5/16	2	115.7
	7-3/4	13SC78	13SCH-13SCHS	3-3/8	11.750	14-3/8	2-11/16	1-7/8	129.6
14SC	7-3/4	14SC78	14SCH	3-7/8	13.875	15-3/8	3-1/4	2	179.9

■ Approximate weight for completely assembled spacer coupling.

⁽¹⁾ 4JSC35 x 1-1/8 has shallow keyseat. ⁽²⁾ "L" dimension and weight will change if one or two short (HS) hubs used.

Note: Refer to page F1-15 to order — specify components separately.

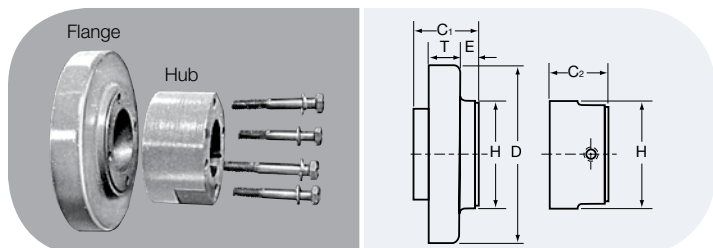

TYPE SC FLANGES AND HUBS

Tables on page F1-15 provide dimensional information for flanges and hubs used for Spacer Couplings. For assembled dimensions, see table above. Any of the sleeves shown on page F1-5 may be used.

Type SC Flanges And Hubs BTS

Selection

Conventional Spacer Design

ILLUSTRATION AND DIMENSIONAL DRAWINGS SHOWN AT BOTTOM OF PAGE F1 – 14.

Coupling Size	Flange Number	For Distance Between Shafts*	For Hub	Dimensions					Weight (lbs.)
				D	E	H	C ₁	T	
4JSC	4JSC35	3-1/8	①	2.460	2-1/16	2	2-1/2	7/16	1.3
5SC	5SC35	3-1/2	5SCH	3.250	51/64	2	1-11/16	19/32	1.3
6SC	6SC35	3-1/2	6SCH-6SCHS	4.000	19/32	2-1/2	1-5/8	23/32	2.0
	6SC44	4-3/8	6SCH-6SCHS	4.000	1-1/32	2-1/2	2-1/16	23/32	2.4
	6SC50	5	6SCH-6SCHS	4.000	1-11/32	2-1/2	2-3/8	23/32	2.7
7SC	7SC35	3-1/2	7SCH-7SCHS	4.625	15/32	2-13/16	1-5/8	25/32	2.5
	7SC44	4-3/8	7SCH-7SCHS	4.625	29/32	2-13/16	2-1/16	25/32	3.0
	7SC50	5	7SCH-7SCHS	4.625	1-7/32	2-13/16	2-3/8	25/32	3.3
8SC	8SC35	3-1/2	8SCH-8SCHS	5.450	9/32	3-1/4	1-5/8	29/32	3.7
	8SC35-10	3-1/2	10SCH-10SCHS	5.450	9/32	4-3/8	1-5/8	29/32	3.5
	8SC44	4-3/8	8SCH-8SCHS	5.450	23/32	3-1/4	2-1/16	29/32	4.3
	8SC50	5	8SCH-8SCHS	5.450	1-1/32	3-1/4	2-3/8	29/32	4.8
	8SC50-10	5	10SCH-10SCHS	5.450	1-1/32	4-3/8	2-3/8	29/32	5.5
9SC	9SC35	3-1/2	9SCH-9SCHS	6.350	1/16	3-5/8	1-11/16	1-1/32	4.1
	9SC44	4-3/8	9SCH-9SCHS	6.350	7/16	3-5/8	2-1/16	1-1/32	5.9
	9SC50	5	9SCH-9SCHS	6.350	3/4	3-5/8	2-3/8	1-1/32	6.4
	9SC50-11	5	11SCH-11SCHS	6.350	3/4	5-1/4	2-3/8	1-1/32	7.0
	9SC70-11	7	11SCH-11SCHS	6.350	1-3/4	5-1/4	3-3/8	1-1/32	10.9
	9SC78-11	7-3/4	11SCH-11SCHS	6.350	2-1/8	5-1/4	3-3/4	1-1/32	12.3
10SC	10SC48	4-3/4	10SCH-10SCHS	7.500	11/32	4-3/8	2-1/4	1-7/32	9.8
	10SC50	5	10SCH-10SCHS	7.500	15/32	4-3/8	2-3/8	1-7/32	10.2
	10SC70-13	7	13SCH-13SCHS	7.500	1-15/32	6-1/8	3-3/8	1-7/32	14.5
	10SC78-13	7-3/4	13SCH-13SCHS	7.500	1-27/32	6-1/8	3-3/4	1-7/32	16.5
	10SC100-13	10	13SCH-13SCHS	7.500	2-31/32	6-1/8	4-7/8	1-7/32	22.5
11SC	11SC48	4-3/4	11SCH-11SCHS	8.625	1/32	5-1/4	1-1/2	1-1/2	12.5
	11SC50	5	11SCH-11SCHS	8.625	1/16	5-1/4	1-9/16	1-1/2	12.6
	11SC70-14	7	14SCH	8.625	1-1/16	6-1/2	2-9/16	1-1/2	16.3
	11SC78-14	7-3/4	14SCH	8.625	1-7/16	6-1/2	2-15/16	1-1/2	18.4
	11SC100-14	10	14SCH	8.625	2-9/16	6-1/2	4-1/16	1-1/2	24.6
12SC	12SC70	7	12SCH-12SCHS	10.000	21/32	5-3/4	2-15/32	1-11/16	23.4
	12SC70-14	7	14SCH	10.000	21/32	6-1/2	2-15/32	1-11/16	21.3
	12SC78	7-3/4	12SCH-12SCHS	10.000	1-1/32	5-3/4	2-27/32	1-11/16	25.3
	12SC78-14	7-3/4	14SCH	10.000	1-1/32	6-1/2	2-27/32	1-11/16	23.4
	12SC100-14	10	14SCH	10.000	2-5/32	6-1/2	3-31/32	1-11/16	29.6
13SC	13SC78	7-3/4	13SCH-13SCHS	11.750	9/16	6-1/8	3-1/4	1-31/32	38.4
14SC	14SC78	7-3/4	14SCH	13.875	1/32	6-1/2	2-23/32	2-1/4	55.2

* Flanges can be mixed to form different Between-Shaft Dimensions. See chart page F1 – 16. ■ Approximate weight for each flange.

Coupling Size	Hub Number	Max Bore	STOCK BORES *		Dimensions			Weight (lbs.)
			Plain Bore	Bore with Standard Keyseat & Set Screw	C ₂	H	Cap Screws Furnished	
4JSC	①	1-1/8	-	5/8 – 7/8 – 1 – 1-1/8* ①	1-1/16	2	-	-
5SC	5SCH	1-1/8	1/2	5/8 – 3/4 – 7/8 – 1 – 1-1/8	1-3/32	2	4 – 10 x 1-1/2	.8
6SC	6SCH	1-3/8	5/8	3/4 – 7/8 – 1 – 1-1/8 – 1-1/4 – 1-3/8	1-7/32	2-1/2	4 – 1/4 x 1-3/4	1.4
	6SCHS	7/8	-	7/8	31/32	2-1/2	4 – 1/4 x 1-1/2	1.1
7SC	7SCH	1-5/8	5/8	7/8 – 1 – 1-1/8 – 1-3/8 – 1-1/2 – 1-5/8	1-15/32	2-13/16	4 – 1/4 x 1-7/8	2.0
	7SCHS	7/8	-	7/8	1-3/32	2-13/16	4 – 1/4 x 1-1/2	1.5
8SC	8SCH	1-7/8	3/4	7/8 – 1 – 1-1/8 – 1-3/8 – 1-1/2 – 1-5/8 – 1-3/4 – 1-7/8	1-23/32	3-1/4	4 – 5/16 x 2-1/4	3.2
	8SCHS	7/8	-	7/8	1-7/32	3-1/4	4 – 5/16 x 1-3/4	2.0
9SC	9SCH	2-1/8	7/8	1 – 1-1/8 – 1-3/8 – 1-1/2 – 1-5/8 – 1-3/4 – 1-7/8 – 2-1/8	1-31/32	3-5/8	4 – 3/8 x 2-3/4	4.2
	9SCHS	1-1/2	-	1-1/8	1-17/32	3-5/8	4 – 3/8 x 2-1/4	3.7
10SC	10SCH	2-3/8	1-1/8	1-5/8 – 1-7/8 – 2-1/8 – 2-3/8	2-11/32	4-3/8	4 – 7/16 x 3-1/4	7.4
	10SCHS	1-5/8	-	1-1/8	1-21/32	4-3/8	4 – 7/16 x 2-1/2	5.5
11SC	11SCH	2-7/8	1-1/8	1-7/8 – 2-1/8 – 2-3/8 – 2-7/8	2-23/32	5-1/4	4 – 1/2 x 3-1/2	12.2
	11SCHS	1-7/8	-	1-1/8 – 1-5/8	1-29/32	5-1/4	4 – 1/2 x 2-3/4	9.3
12SC	12SCH	2-7/8	1-3/8	2-1/8 – 2-3/8 – 2-7/8	2-31/32	5-3/4	4 – 5/8 x 4	16.6
	12SCHS	2-1/2	-	2-3/8	2-17/32	5-3/4	4 – 5/8 x 3-1/2	14.1
13SC	13SCH	3-3/8	1-3/8	2-3/8 – 2-7/8 – 3-3/8	3-11/32	6-1/8	4 – 5/8 x 4-1/2	19.9
	13SCHS	2-1/2	-	2-1/8 – 2-3/8	2-15/32	6-1/8	4 – 5/8 x 3-1/2	16.0
14SC	14SCH	3-7/8	1-5/8	2-3/8 – 2-7/8 – 3-3/8 – 3-7/8	3-27/32	6-1/2	4 – 5/8 x 5	24.2

① FOR 4JSC the hub is an integral part of the flange. 4JSC x 1-1/8 has 1/4 x 1/16 shallow keyseat.

* See page F1 – 10 for bore tolerances and page F1 – 13 for standard keyseat dimensions.

② If using 10SCHS hub, 7/16-14NC x 2-1/4 long capscrew needed (not furnished).

■ Approximate weight for each hub.

Between Shaft Spacings

Selection

Spacer couplings are available for most popular Distance Between Shaft Ends (DBSE) dimensions. Other spacings can be achieved by mixing flanges.

The “Standard” column provides spacings using identical flanges; the “Combination” column mixes flanges; the column headed “Semi-Spacer” uses one flange that is not made for spacer coupling applications and thus does not have a detachable hub.

To select couplings for various DBSEs, please see our Coupling Selector Program at www.TBWoods.com/Select

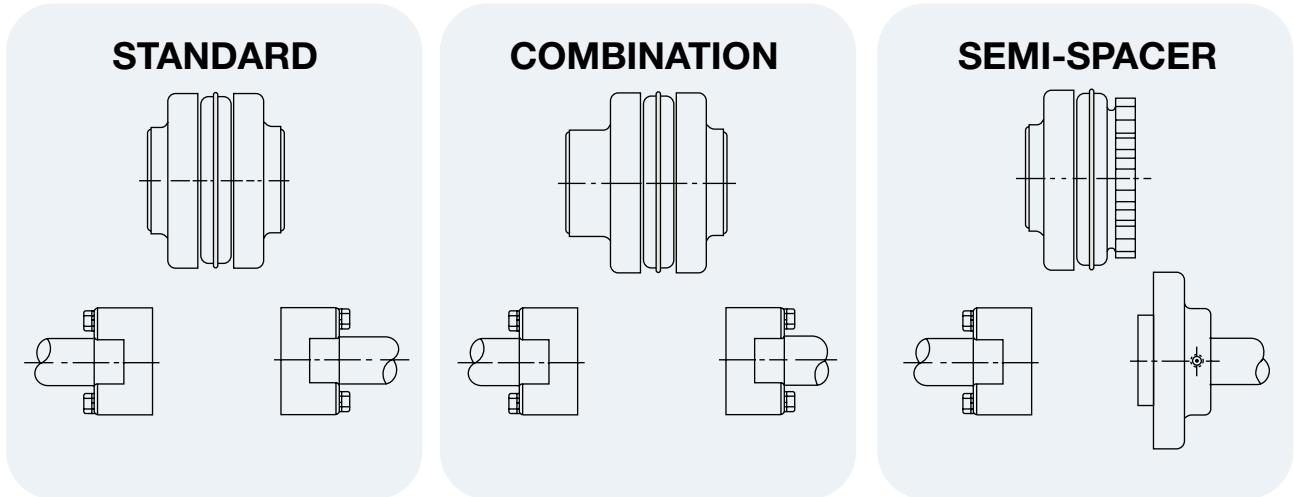

STANDARD	
Spacing	Use Flanges*
3-1/2	2(-) SC35
4-3/8	2(-) SC44
5	2(-) SC50
7	2(-) SC70
7-3/4	2(-) SC78
10	2(-) SC100

COMBINATION	
Spacing	Use Flanges*
3-15/16	SC35 & SC44
4-1/4	SC35 & SC50
4-11/16	SC44 & SC50
5-1/4	SC35 & SC70
5-5/8	SC35 & SC78
5-11/16	SC44 & SC70
6	SC50 & SC70
6-1/16	SC44 & SC78
6-3/8	SC50 & SC78
6-3/4	SC35 & SC100**
7-3/16	SC44 & SC100**
7-3/8	SC70 & SC78
7-1/2	SC50 & SC100
8-1/2	SC70 & SC100
8-7/8	SC78 & SC100

SEMI-SPACER	
Spacing	Use Flanges*
1-7/8	S & SC35
2-5/16	S & SC44
2-5/8	S & SC50
3-5/8	S & SC70
4	S & SC78
5-1/8	S & SC100

* Check individual coupling size for flange availability.

** Non-Stock

Note: Other combinations available — consult factory or see www.TBWoods.com/Select

Selection Dimensions

CLAMP HUB – SPACER DESIGN

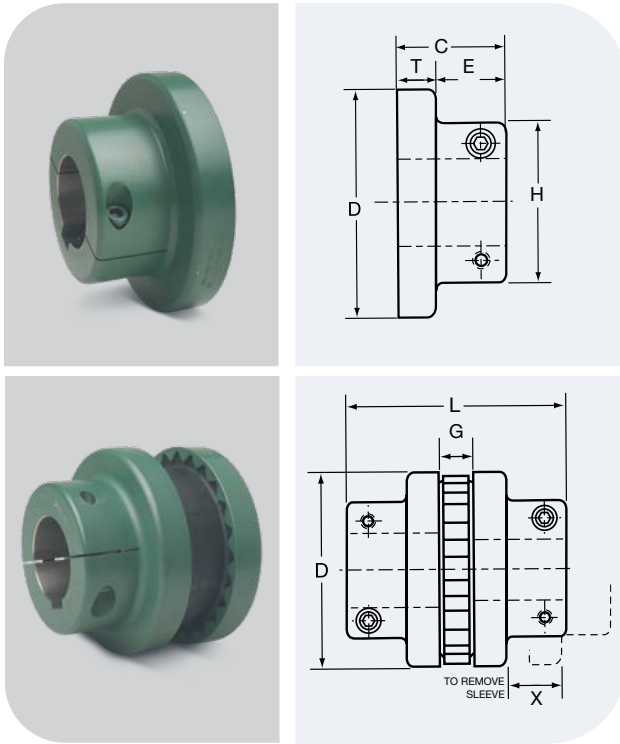

FLANGES

Sure-Flex Plus® Type C Clamp Hub flanges employ integral locking collars and screws to assure a secure shaft connection without marring the shaft surface. One setscrew is furnished over the key. The clamp hub flange is often used in applications that require easy seal replacement on equipment using face seals, as the clamp hub eliminates the need for a second set screw at 90 degrees from the key.

COUPLINGS

Type C Clamp Hub Couplings can use all sleeve types shown on page F1-5. Type C couplings may often be used where spacer couplings are required.

Spacing between internal flange hubs equals G.

To order complete couplings, specify coupling size with flange symbol (C), giving bore required. Refer to page F1-3 to order the required coupling.

DIMENSIONS (in.)

Flange Size	Stock Bores	Min Bore	Maximum Bore		Distance Between Shafts		Dimensions							Weight (lbs.)*
			Standard Keyseat	Shallow Keyseat	Min	Max	C	D	E	G	H	L	X	
6C	1-1/8, 1-7/8, 40mm	7/8	1-5/8	1-7/8	2	2-3/4	1-15/16	4.000	1.16	7/8	3	4-3/4	1	2.6
7C	1-3/8, 1-7/8, 35mm, 40mm	1-1/8	1-7/8		2-5/16	3-7/16	2-3/16	4.625	1.41	1-1/16	3-1/4	5-7/16	1-3/16	3.6
8C	1-3/8, 1-5/8, 1-3/4, 1-7/8, 2-1/8, 2-1/4, 2-3/8, 40mm	1-3/8	2-1/4	2-3/8	2-9/16	4	2-1/2	5.450	1.59	1-1/8	3-7/8	6-1/8	1-3/8	6.5
9C	1-5/8, 1-3/4, 1-7/8, 2, 2-1/8, 2-1/4, 2-3/8, 2-1/2	1-5/8	2-1/2	2-11/16	3-1/16	4-5/8	3	6.350	1.97	1-7/16	4-1/4	7-7/16	1-9/16	9.8
10C	1-5/8, 1-7/8, 2-1/4, 2-3/8, 2-1/2	1-5/8	2-7/8		3-9/16	5-1/4	3-1/2	7.500	2.28	1-11/16	5	8-11/16	1-13/16	16.6
11C	2-1/8, 2-3/8, 2-1/2	1-7/8	3-3/8		4-1/8	5-7/8	4	8.625	2.5	1-7/8	5-3/8	9-7/8	2-1/8	26.0
12C	2-1/8	1-7/8	3-3/8		4-7/8	6-1/2	4-3/8	10.000	2.69	2-3/8	6	11-1/8	2-3/8	38.3

For Standard keyseat dimensions, see chart page F1-13. * Approximate weight of one flange.

Bore Tolerances for Type C Flanges

These bores provide a slip fit.

Bore (in.)	Tolerance (in.)
Up to and including 2"	+0.0005 to +0.0015
Over 2"	+0.0005 to +0.0020

Shallow Keyseat Dimensions

Some large bore Type C flanges are supplied with shallow keyseats. In these cases, a rectangular key is furnished. The flanges and bores involved are as follows:

Size	Bore Range	KS	Key Furnished
6C	1- 11 /16 to 1 -7/8	1/2 X 1/16	1/2 x 5/16 x 1-7/8
8C	2-5/16 to 2 -3/8	5/8 x 1/16	5/8 x 3/8 x 2-1/ 2
9C	2-7/16 to 2-11/16	5/8 x 3/16	5/8 x 1/2 x 3

Sure-Flex Plus® Couplings

Installation Instructions

Installation Instructions

Sure-Flex Plus flanges (outer metallic parts) and sleeves (inner elastomeric elements) come in many sizes and types. First, determine the size and type of components being used. Check maximum RPM values in the table below against operating speed. Remove all components from their boxes, and loosely assemble the coupling on any convenient surface. ((If using a two-piece E or N sleeve, do not install the wire ring at this time.))

- 1** Inspect all coupling components and remove any protective coatings or lubricants from bores, mating surfaces and fasteners. Remove any existing burrs, etc. from the shafts.
- 2** Slide one coupling flange onto each shaft using keys where required. When using Type B flanges, follow the instructions furnished with the Sure-Grip bushings.
- 3** Position the flanges on the shafts to approximately achieve the G_1 dimension shown in the table. It is usually best to have an equal length of shaft extending into each flange. Move one flange to its final position. Torque fasteners to proper values. Slide the other flange far enough away to install the sleeve. With a two-piece sleeve, do not move the wire ring to its final position; allow it to hang loosely in the groove adjacent to the teeth.

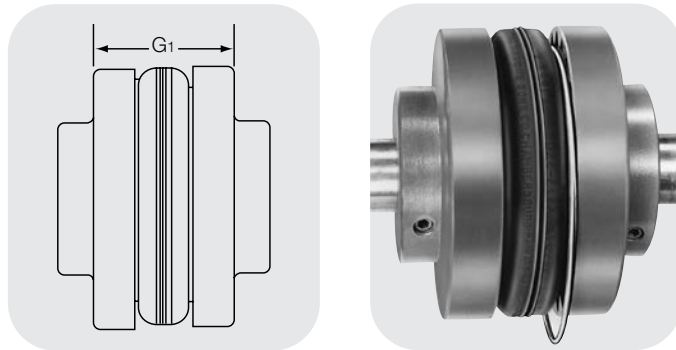

4 Slide the loose flange on the shaft until the sleeve is completely seated in the teeth of each flange. (The " G_1 " dimension is for reference and not critical.) Secure the flange to the shaft. Different coupling sleeves require different degrees of alignment precision. Locate the alignment values for your sleeve size and type in the table.

5 Check parallel alignment by placing a straight-edge across the two coupling flanges and measuring the maximum offset at various points around the periphery of the coupling without rotating the coupling. If the maximum offset exceeds the figure shown under "Parallel" in the table, realign the shafts.

6 Check angular alignment with a caliper. Measure from the outside of one flange to the outside of the other at intervals around the periphery of the coupling. Determine the maximum and minimum dimensions without rotating the coupling. The difference between the maximum and minimum must not exceed the figure given under "Angular" in the table. If a correction is necessary, be sure to recheck the parallel alignment.

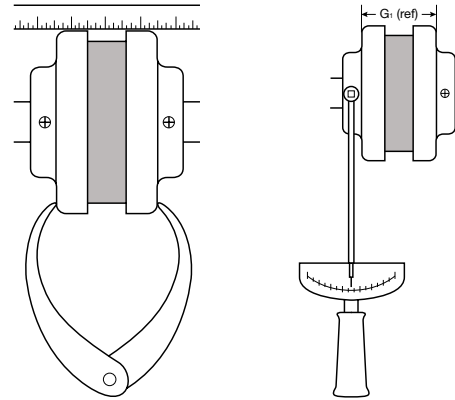

MAXIMUM RPM AND ALLOWABLE MISALIGNMENT (Dimensions in inches)						
Sleeve Size	Maximum RPM	G_1 (ref)	Types JE, JN, JES, JNS, E & N		*Type H, HS	
			Parallel	Angular	Parallel	Angular
3	9200	1.2	.010	.035		
4	7600	1.5	.010	.043		
5	7600	1.9	.015	.056		
6	6000	2.4	.015	.070	.010	.016
7	5250	2.6	.020	.081	.012	.020
8	4500	2.9	.020	.094	.015	.025
9	3750	3.5	.025	.109	.017	.028
10	3600	4.1	.025	.128	.020	.032
11	3600	4.9	.032	.151	.022	.037
12	2800	5.7	.032	.175	.025	.042
13	2400	6.7	.040	.195	.030	.050
14	2200	7.8	.045	.242	.035	.060
16	1500	10.3	.062	.330		

Note: When using a VFD with a centrifugal pump or fan, reduce the above values by 1/2.

***Type H and HS sleeves should never be used as direct replacements for EPDM or Neoprene sleeves.**

7 If the coupling employs the two-piece sleeve with wire ring, move the ring into its groove in the center of the sleeve. If necessary, use soapy water and lever the ring with a blunt tool.

8 Install coupling guards per OSHA requirements.

CAUTION: Coupling sleeves may be thrown from the coupling assembly with substantial force if subjected to a severe shock load.