

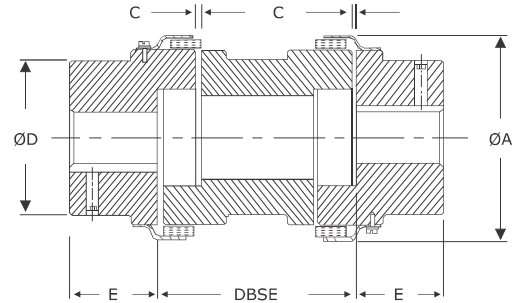

Riddhi Engineering Company

UTL UWS COUPLINGS (Two Snap wrap Elastomers with Spacer)

UTL FLEXIBLE COUPLINGS



FEATURES

- Specially designed for machines requiring space for maintenance
- Snap wrap design present correct distance between hubs, using raised dimple on leg of the snap wrap
- Snap wrap are unaffected by moisture, grease and oils including ono-aromatic and non-ketone solvents
- Temperatures within the range - 40°C to + 100°C
- Inspection / Replacement of snap wrap within 5 minutes and only screw driver is required
- Having 2 snap-wrap elastomers means double flexibility
- Floating light weight aluminium spacer
- Range up to 327 Nm
- Maximum permissible misalignment: angular 1°, parallel 0.4 mm & axial 3 mm (initial alignment must be 25 % of maximum)

DIMENSIONS & TECHNICAL DATA

Size	Rated Torque Nm	kW Rating at			Dimensions are in mm						Torsioal Stiffness Nm / rad	Wt in. Kg approx.	Moment of inertial kg.m ²	
		100 rpm	1500 rpm	3000 rpm	Min. Bore	Max. Bore	DBSE	ØA	ØD	E				C
95	21.1	0.22	3.3	6.6	10	28	90, 100, 135, 140, 180	64	49	25	2	275	1.10	On request UTL will provide data. According to spacer length.
100	46.4	0.49	7.35	14.7	10	35		78	57	35	2	688	1.13	
110	89	0.93	13.95	27.9	15	42		96	76	43	3	1719	3.93	
150	141	1.49	22.35	44.7	15	48		111	80	45	3	2120	4.97	
190	190	2.01	30.15	60.3	20	60		130	102	54	3	3495	9.00	
225	265	2.76	41.4	82.8	20	65		142	111	64	3	4584	12.20	
226	327	3.43	51.45	102.9	25	70		153	115	70	3	6990	15.60	

• For non standard DBSE please contact UTL

MATERIAL SPECIFICATIONS

Spacer	Size - 095-226	Aluminium	AL	BS 1490 - LM 4
Hub	Size - 095-225	Cast Iron	CI	DIN 1693 GG 20
Hub	Size - 226	Cast Iron	CI	DIN 1693 GG 25
Snap wrap 80° Shore A	All Size	Synthetic Rubber	NBR	ASTM D2000 BG 810
Outer ring	Size - 095-226	Mild. Steel	CRCA	BS 970

• Alternative T Cushion for higher power ratings is available on request.

Snap wrap 92° Shore A	All Size	Synthetic Rubber	NBR	ASTM D2000 BG 910	Torque 1.6 times of standard
Snap wrap 80° Shore A	All Size	Synthetic Rubber	EPDM	ASTM D2000 AA 810	Torque as per standard
Snap wrap 92° Shore A (Yellow Colour)	All Size	Polyurethane	PU		Torque 1.8 times of standard
Snap wrap 98° Shore A (Red Colour)	All Size	Polyurethane	PU		Torque 2.5 times of standard

• Max speed not to exceed 3300 rpm

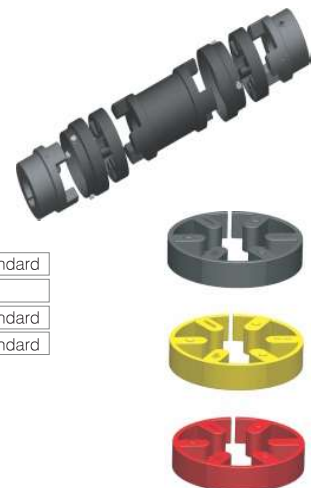

• For temperature range of elastomers please see on page no. 37 - coupling selection



Riddhi Engineering Company

www.couplings-mounts.com
sales@riddhiengineeringco.com
+91 74900 32784