



Riddhi Engineering Company

www.couplings-mounts.com
sales@riddhiengineeringco.com
+91 74900 32784

We make drive systems comfortable and reliable.

elastic drive shaft

with unique centering system

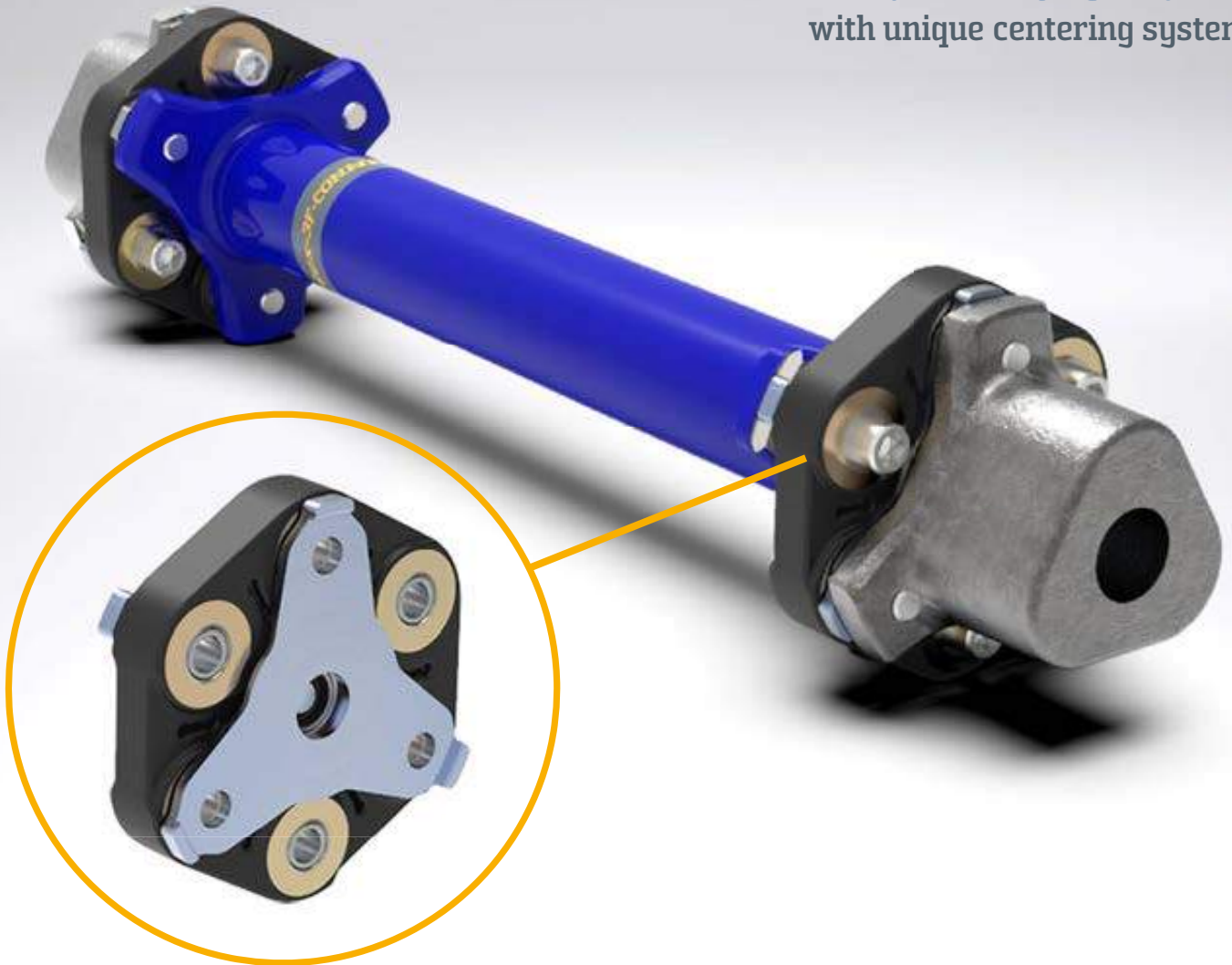

SGFlex-3FD-CONNECT



Riddhi Engineering Company

www.couplings-mounts.com

sales@riddhiengineeringco.com

+91 74900 32784



SGFlex-3FD-CONNECT

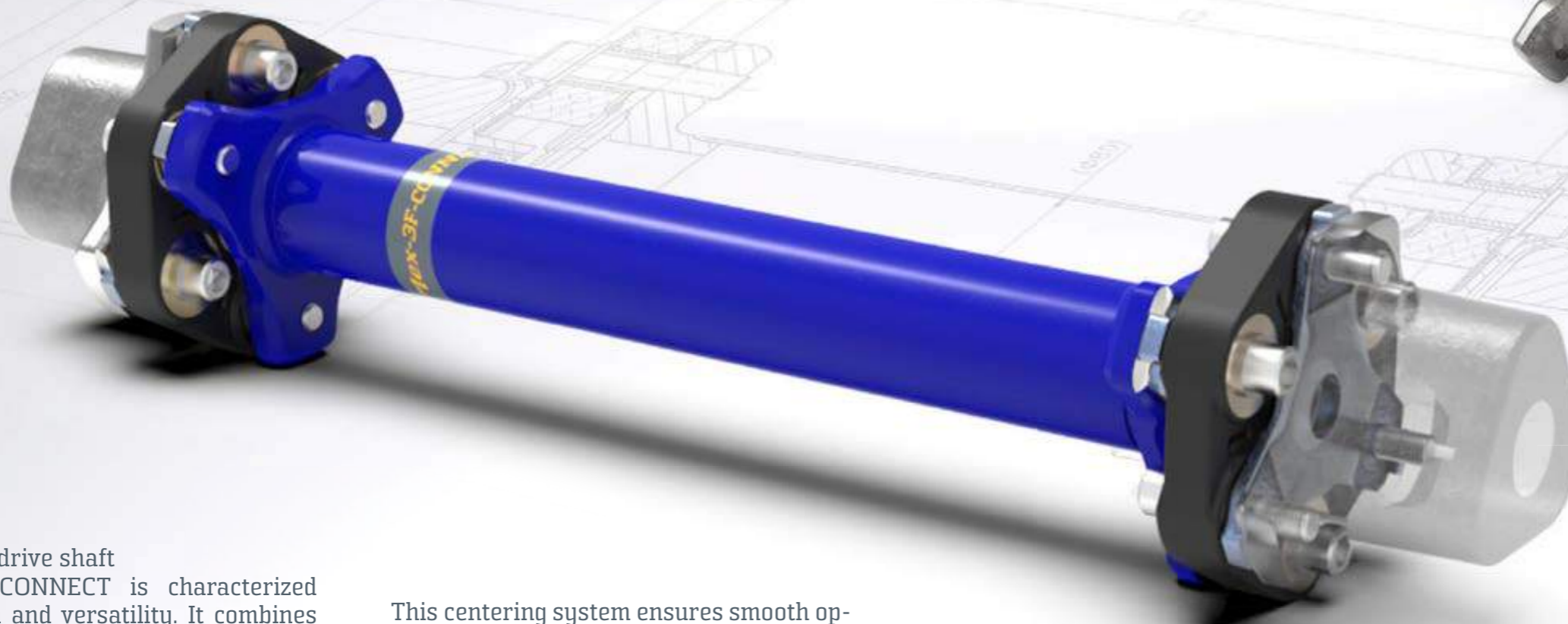

Frictional connection thru shrink disc



Frictional connection thru a clamping set



Taper Lock



Spline connection with fastening function



Key connection for bigger shafts thru unique 3-edge design



Key connection with threads for fixing bolts

The flexible drive shaft SGFlex-3FD-CONNECT is characterized by its design and versatility. It combines the advantages of drive shafts with the advantages of flexible couplings, thus providing a vibration-damping alternative to drive shafts with universal joints.

The „D“ in the product name designates the first type from the new series, and is available in six standard sizes.

Integrated into the shaft are the forged flange from the SGFlex-3F series which has proven itself in the industry, paired with matching intermediary shafts and the new patented centering system SGFlex-3F-ALIGN.

This centering system ensures smooth operation even at high rotational speeds and allows assembly to take place without having to shift the drive and driven units.

These maintenance-free cardan shafts can easily bridge large shaft gaps. At the same time, aggregates are protected via the reduction of oscillations and vibrations thanks to the proven Tenpu® fiber technology.

This shaft system can also be operated at a zero-degree bending angle, which is usually not possible in designs with equal velocity or universal joints.

➤➤ The SGFlex-3FD-CONNECT can also operate at 0° angle bending.



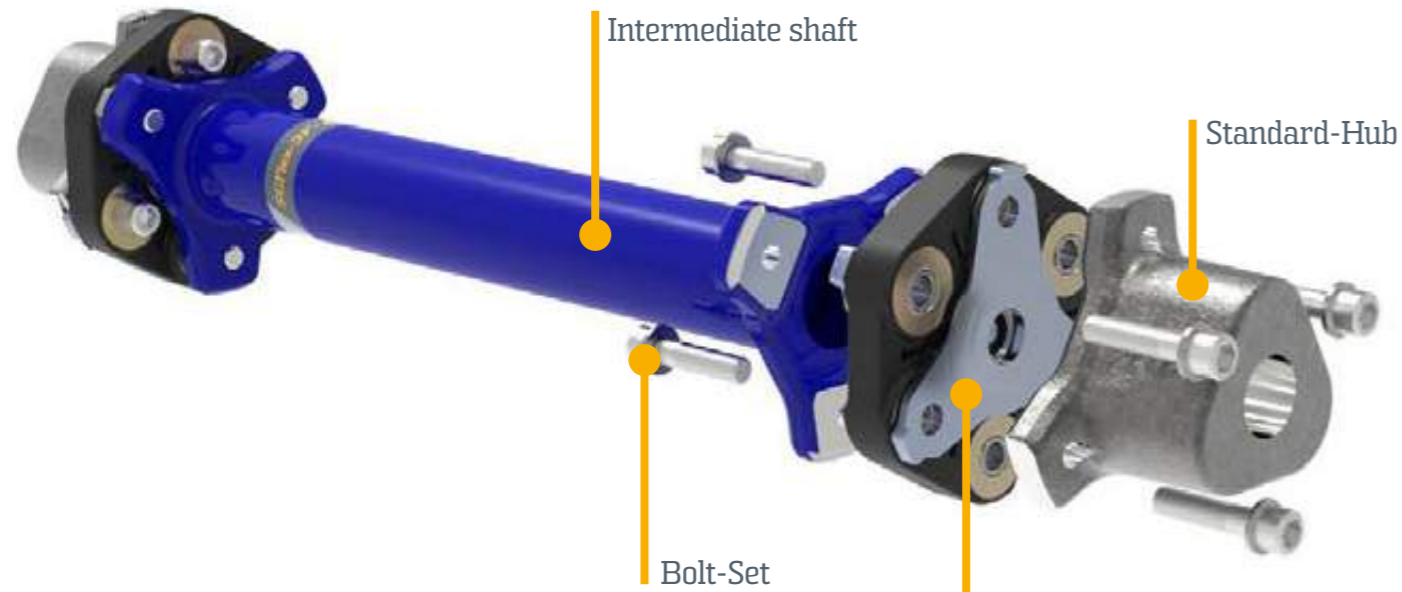

SGFlex-3F-ALIGN with SGF Alignment Support

The patented centering system SGFlex-3F-ALIGN combines resilience and flexibility of the flex coupling with the support feature of the SGF Alignment Support.

Benefits are

- » Lubricant-free
- » Maintenance-free
- » Millions installed worldwide
- » Adapted to use in system with flexible couplings

Thanks to the unique structure of the flexible coupling with centering, this system can be radially disassembled and reassembled simply by removing the screws. The drive and driven machines do not need to be moved.



RADIAL DISASSEMBLY

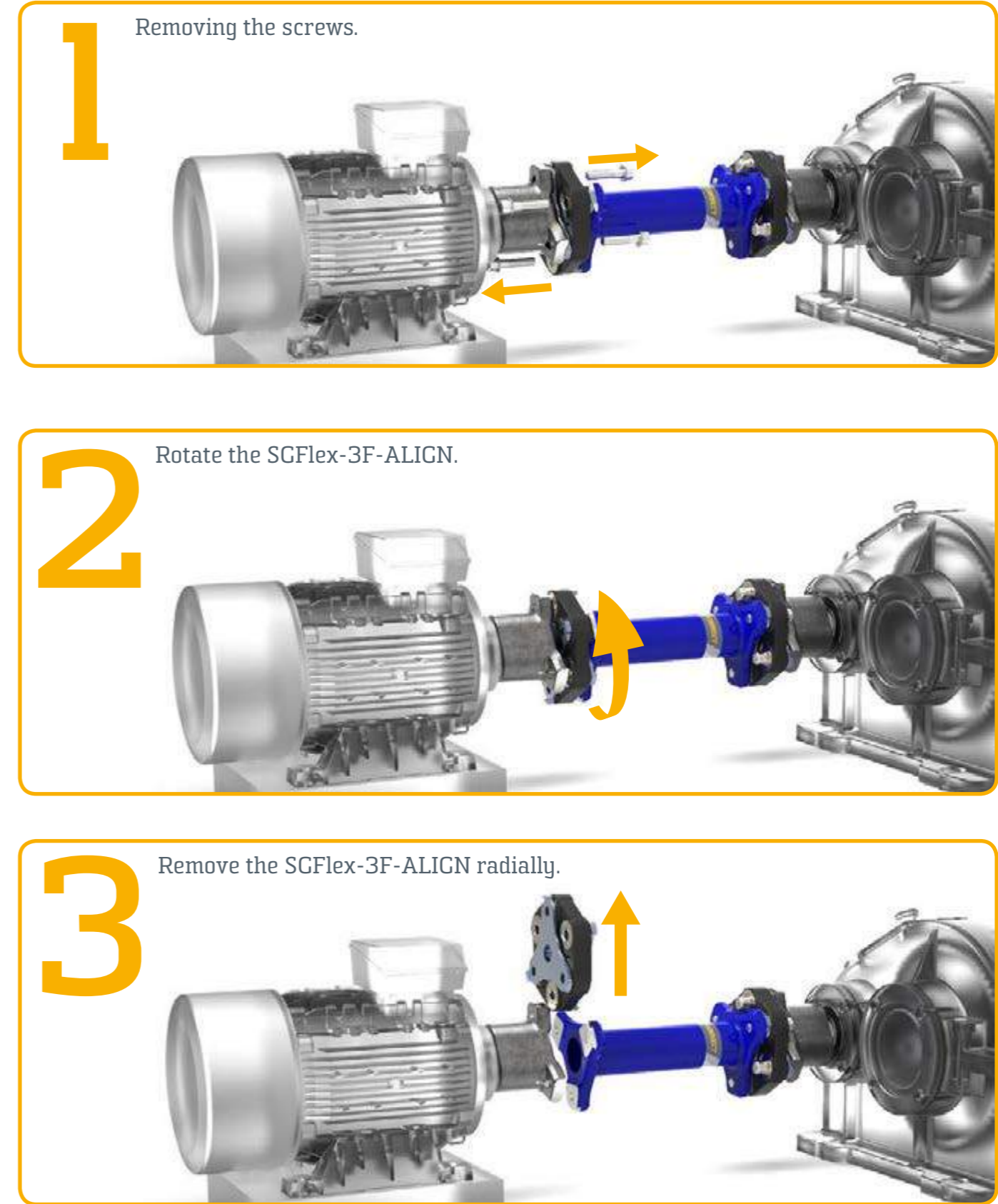

1

Removing the screws.

2

Rotate the SGFlex-3F-ALIGN.

3

Remove the SGFlex-3F-ALIGN radially.



APPLICATIONS, BENEFITS AND PROPERTIES

EXAMPLES OF CUSTOMIZED SOLUTIONS



Torque is transmitted almost exclusively via the vulcanised-in cord inlays (Tenpu® fiber technology) by the unique SGF tension-force-principle.

The cord inlays (**Tenpu® Fiber technology**) serve to damp torque peaks and to absorb start-up impacts. The rubber takes on a supporting and protective function for the cord packets and serves to isolate noises due to the interruption of the structure-borne noise path.

Properties

- » Bridging of large shaft distances
- » High power density due to unique power transmission via Tenpu® technology
- » Electrically insulating upon request
- » Patented centering system SGFlex-3F-ALIGN
- » Closed system

Benefits

- » Maintenance free
- » Operation without offset possible
- » High torque transmission at small installation space
- » Easy to assemble or disassemble without moving the drive or driven component
- » Smooth run due to unique centering system

Common Applications

- » Drivetrain of track vehicles
- » Connection between electric engine and roller conveyor
- » Drivetrain of jet impellers for boats
- » For connecting combustion engines and generators
- » Drivetrain of fan propellers for cooling towers



Application: Mobile rock crusher
Characteristic: Flange connection ISO 7646 / DIN 15451



Application: Driveshaft for Trimaran
Characteristic: Lightweight construction - high performance CFRPK & Titanium



Application: Test bench
Characteristic: Connection to the motor flywheel

Robust. Flexible. Unique.

All parts can be protected against corrosion by either electroplated coating or paint, which protects the steel parts against aggressive media and environmental impacts. Applications in corn harvesting machines, inside biogas fermenters and in the salty area of the marine industry prove the excellent resistance against unfriendly environment.

SCFlex-3FD-CONNECT flanges and all other coupling parts are built together by a simple screw connection, using high quality bolts (grade 10.9) and high quality washers (300 HV hardness).

The screw connection is easy to install, as the bolts are bolted directly into the flange material. Due to this, the SCFlex coupling can be replaced without disassembling the metal parts, just by loosen the bolts and replacing the flexible disc element in radial direction.

In order to choose the right coupling size for your application, calculate the nominal torque T_N of your system.

$$T_N = \frac{9550 \times P \text{ [kW]}}{n \text{ [rpm]}}$$

$$T_{KN} \geq T_N$$

T_N	Nominal torque of the system in Nm
T_{KN}	Max permissible nominal torque of flexible coupling
P	Power in kW
n	Speed in rpm

Further take following points into account:

- » Due to the constructive composition of SGF flexible couplings, normally it is not necessary to correct T_N for machine types or thermal influences.
- » Check for the limits of shaft length (L2), maximum torque (T_{KMaxl}) and displacements (D_{Kr} , D_{Ka} , D_{Kw})
- » In addition to considering static loads when selecting a coupling size, we always recommend a calculation of the vibratory behaviour of the drive train to avoid undesired resonance phenomena.
- » Under unfavourable conditions, running the drive train in resonance mode can lead to destruction of individual components within minutes and should be avoided on principle.
- » The data needed for the calculation is given in the technical datasheet according to the SCFlex coupling and explained in the technical data explanation SCF-TL-001 (either available on request or download at www.sgf.com).
- » At high load frequencies, take heed that the maximum permissible power loss of the individual flexible coupling is not exceeded.
- » If an SCFlex-3FD-CONNECT is used as a replacement solution in an existing system, bearings loads may increase due to altered rigidities.

TECHNICAL DATA

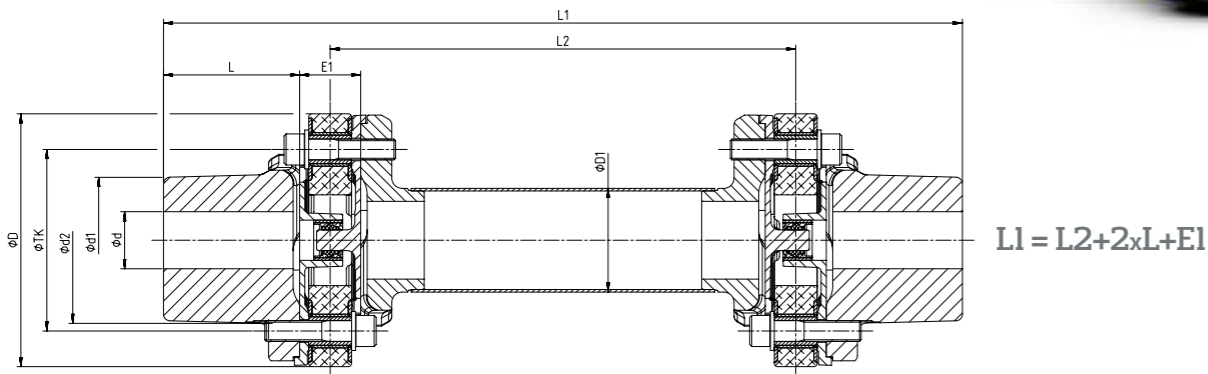

$$L1 = L2 + 2 \times L + E1$$

Size (TK)	Torque		D	D1	E1	L	L2		Pilot	d		d1	d2	used flexible coupling	Bolt	Tightening Torque	Order number	
	T _{KN} *	T _{KMax}					min.	max.		Max**	mm						mm	Description
075	210	420	101	50	34	60	174	2000	-	42 1 5/8"	50	66	SGFlex-075.02	M10x45	60	SGFlex-3FD-075-CONNECT	GK-10690	
096	420	840	132	60	42	71	182	2000	19	60 2 3/8"	70	97	SGFlex-096.02	M12x55	130	SGFlex-3FD-096-CONNECT	GK-10691	
120	740	1480	162	60	44	90	194	2000	29	70 2 3/4"	82	109	SGFlex-120.05	M16x60	165	SGFlex-3FD-120-CONNECT	GK-10692	
140	1400	2800	195	80	47	105	207	2000	44	80 3 1/8"	97	129	SGFlex-140.04	M16x70	165	SGFlex-3FD-140-CONNECT	GK-10693	
180	2040	4080	237	102	51	125	225	2000	54	102 4"	126	158	SGFlex-180.02	M22x75	290	SGFlex-3FD-180-CONNECT	GK-10694	
220***	3240 / 1730	6480 / 3460	281	120	55	155	225	2000	64	127 5"	150	193	SGFlex-220.02	M24x80	335	SGFlex-3FD-220-CONNECT	GK-10695	

* Nominal Torque, for further information on technical data see SGF-TL-001, ** maximal diameter for key way connection, *** pay attention to rotational direction acc. to SGF-TL-016

The forged 3-arm flanges are supplied with a pilot hole, which allows flexible adjustment of the bore to the specific needs. The max. bore diameter for key connections according to DIN 6885-1 or ASME B17.1 is given in the table at d_{Max}. Special bore geometries or flanges without pilot hole are also available on request. The SGFlex-3FD-CONNECT is delivered

as an unassembled set, all necessary bolts and connection parts are included. The standard balancing quality of the SGFlex-3FD-CONNECT is G40 - balancing quality G16 is also available on request. The length of the intermediate shafts will be machined according to the customer requirements for each order. Therefore the length needs to be mentioned in the order as shown in the example below.

Order example:

The order number consists of description of part number and total length. Here an example for SGFlex-3FD-140-CONNECT with 600 mm total length (L1).

Quantity	Description	Part number - total length (L1)
1 x	SGFlex-3FD-140-CONNECT	GK-10693 - 600

↑
L1 = L2 + 2xL + E1

TECHNICAL DATA

Permitted speed over shaft length L2

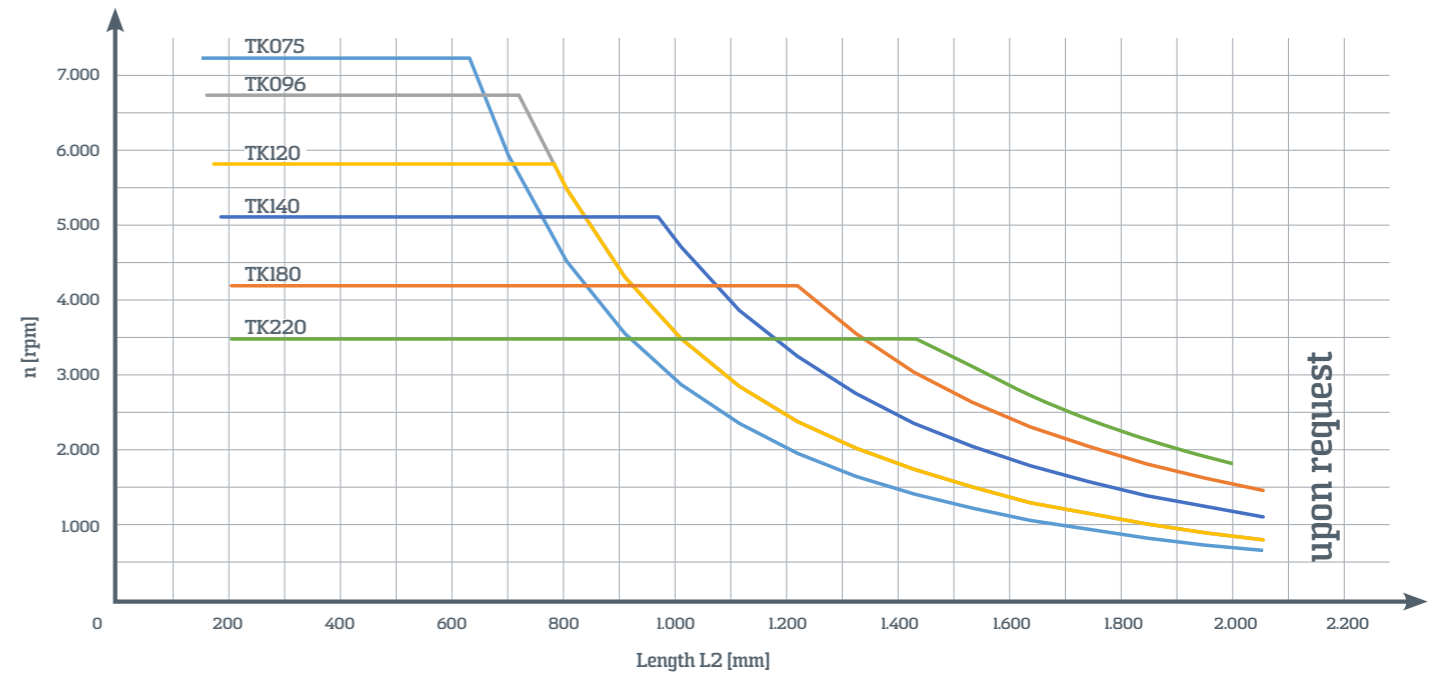

Performance

Size (TK)	Flexible coupling	Part number	T _{KN}	T _{KW}	T _{KMax1}	T _{KMax2}	Max. Speed n _{max}
[mm]			[Nm]	[Nm]	[Nm]	[Nm]	[rpm]
075	SGFlex-075.02	GA000-024	210	105	420	1050	7200
096	SGFlex-096.02	GA000-029	420	210	840	2100	6700
120	SGFlex-120.05	GA000-015	740	370	1480	3700	5800
140	SGFlex-140.04	GA000-019-Z1	1400	560	2800	7000	5100
180	SGFlex-180.02	GA000-027	2040	1020	4080	10200	4200
220	SGFlex-220.02*	GA000-003	3240 / 1730	1620	6480 / 3460	16200 / 8600	3500

For explanation of technical data see SGF-TL-001

* pay attention to rotational direction acc. to SGF-TL-016

For further information a technical data sheet for each flexible coupling is available upon request.

Ød1

» maximum diameter (e.g. for calculation of the 3-edge part of the flange inner clamping sets of the max diameter for shrink discs)

Ød2

» maximum rotational diameter of the 3-edge part of the flange

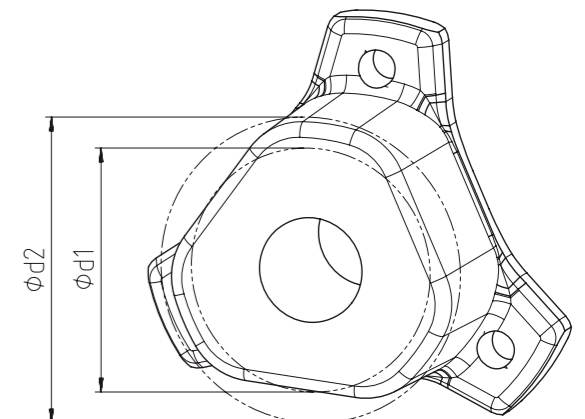

TECHNICAL DATA - DISPLACEMENTS

Radial displacement

The maximum radial displacement ΔK_r of the drive shaft results from the maximum angular misalignment ΔK_w of the individual joints and the distance of the gimbal points L2.

$$\Delta K_r = \tan \Delta K_w \times L2$$

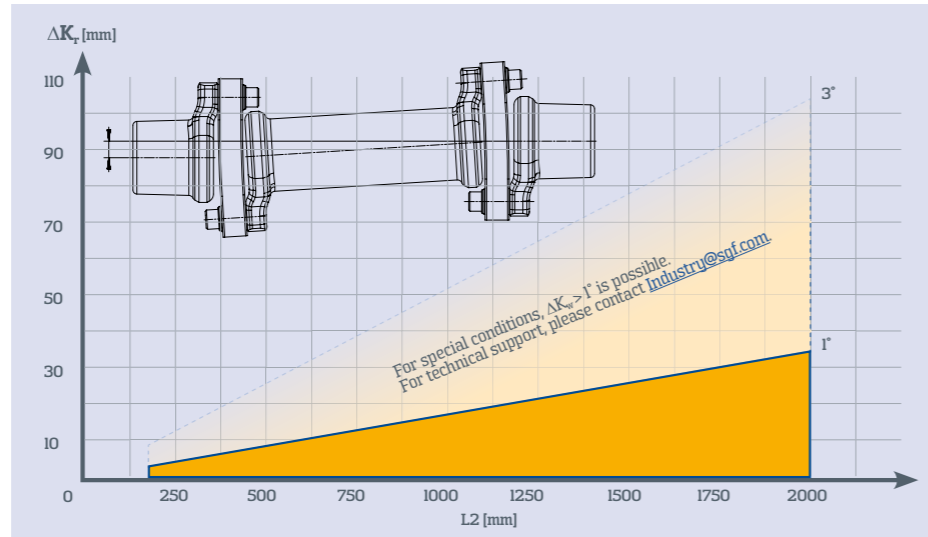

Axial- and Angular Displacement

The two steering levels of the drive shaft are able to compensate for axial and angular misalignments.

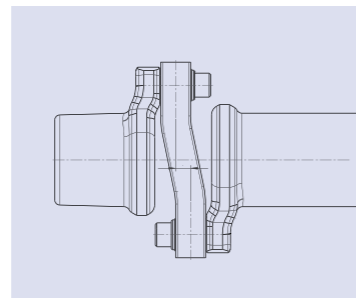

Max. axial displacement ΔK_a

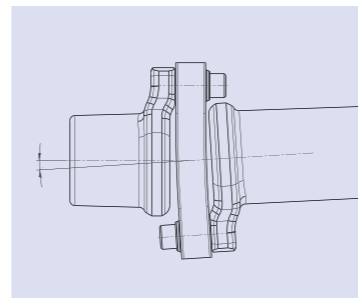

Max. angular displacement ΔK_w

The values given in the table are maximum values per steering level and are only considered to be endurance strength for the individual analysis.

If axial misalignment occurs in different directions simultaneously up to the respective maximum value, a reduced durability is to be expected.

Size (TK) [mm]	used flexible coupling	K_a [mm]	ΔK_w [°]
075	SGFlex-075.02	0,6	1
096	SGFlex-096.02	0,8	1
120	SGFlex-120.05	1,0	1
140	SGFlex-140.04	1,2	1
180	SGFlex-180.02	1,5	1
220	SGFlex-220.02	1,9	1

TECHNICAL DATA - SINGLE PARTS

SGFlex-3F-ALIGN alignment unit

This assembly includes a SG-Flex flexible coupling and the patented alignment unit for the SGFlex-3FD-CONNECT or for connection to existing components.

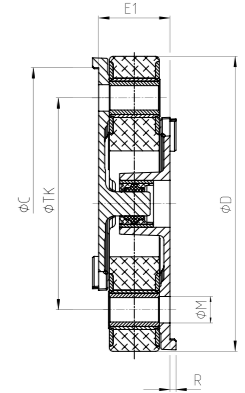

Size (TK) [mm]	Torque		E1 [mm]	C	D [mm]	M [mm]	R [mm]	used flexible coupling	Order number	
	T_{KN}^* [Nm]	T_{KMax} [Nm]							Description	Part number
075	210	420	34	94 H7	101	10,15	4	SGFlex-075.02	SGFlex-3F-075-ALIGN	GK-10706
096	420	840	42	122 H7	132	12,15	4	SGFlex-096.02	SGFlex-3F-096-ALIGN	GK-10707
120	740	1480	44	148 H7	162	16,15	4	SGFlex-120.05	SGFlex-3F-120-ALIGN	GK-10708
140	1400	2800	47	180 H7	195	16,15	4	SGFlex-140.04	SGFlex-3F-140-ALIGN	GK-10709
180	2040	4080	51	225 H7	237	22,15	6	SGFlex-180.02	SGFlex-3F-180-ALIGN	GK-10710
220***	3240 / 1730	6480 / 3460	55	265 H7	281	24,15	6	SGFlex-220.02	SGFlex-3F-220-ALIGN	GK-10711

* Nominal Torque, for further information on technical data see SCF-TL-001, *** pay attention to rotational direction acc. to SCF-TL-016

Bolt-Set

A bolt-set contains six cylinder screws of quality class 10.9 as well as six washers of quality class 300 HV suitable for the respective size.



suitable for	Tightening Torque***	Size	Order number	
			Description	Part number
SGFlex-3F-075-ALIGN	60	M10x45	Bolt-Set M10x45	BI-10024
SGFlex-3F-096-ALIGN	130	M12x55	Bolt-Set M12x55	BI-10025
SGFlex-3F-120-ALIGN	165	M16x60	Bolt-Set M16x60	BI-10026
SGFlex-3F-140-ALIGN	165	M16x70	Bolt-Set M16x70	BI-10027
SGFlex-3F-180-ALIGN	290	M22x75	Bolt-Set M22x75	BI-10028
SGFlex-3F-220-ALIGN	335	M24x80	Bolt-Set M24x80	BI-10029

*** Tightening torque designed for screw connection with SGFlex-3F flanges

Description Technical Data

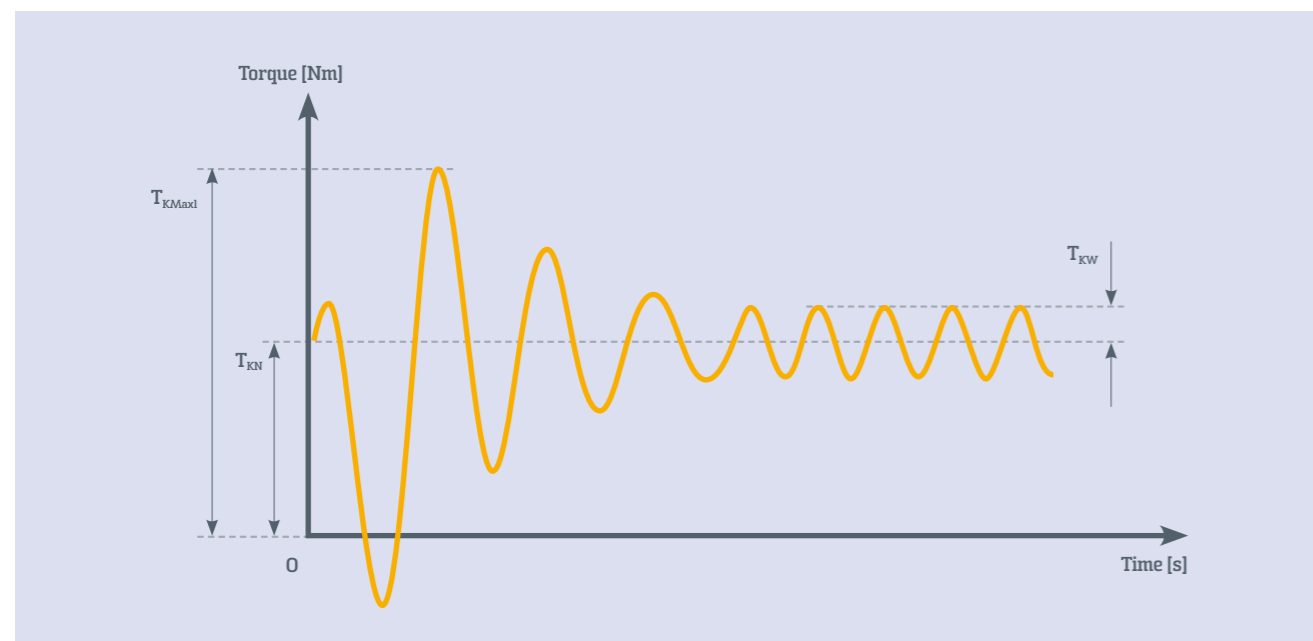

Nominal torque T_{KN}

T_{KN} is the nominal torque of the elastic drive shaft. This torque can be permanently transferred in full by the elastic drive shaft.

Maximum torque T_{KMax1}

Torques at values of T_{KMax1} occur regularly in the normal operation of a machine or plant and can be transferred by the elastic drive shaft without damage as long as the load develops for a short time only and with a frequency not greater than 50,000 load cycles.

Torque peaks at the value of T_{KMax1} typically occur when starting or stopping, shifting, accelerating or braking.

Maximum torque T_{KMax2}

Torques at a value of T_{KMax2} do not occur in normal operation of a machine or plant, but can still be transferred by the elastic drive shaft without destroying it. Massive damage to the elastic drive shaft as well as damage to the screw connections may result, so that only emergency operation of the elastic drive shaft may be possible following the application of the T_{KMax2} load. Torques at a value of T_{KMax2} seldom

occur, e.g. in cases of damage to the machine, emergency shut-down or abuse. Following the occurrence of torques at a value of T_{KMax2} we generally recommend replacing the elastic drive shaft as well as screw connection parts.

Permissible continuously oscillating torque T_{KW}

The permissible continuously oscillating torque T_{KW} is the maximum permissible torque superimposed on the nominal torque. The specification of T_{KW} is given as vibratory amplitude (peak value).

Maximum permissible speed n_{max}

The maximum permissible speed n_{max} can be completely utilized continuously. The specified rpm value applies irrespective of the operating temperature as long as the indicated limit values for the operating temperature are complied with. Refer to the SGF-TL-016 operating and assembly instructions drive shafts for the operating temperature limits.

SGFlex-LC

Nominal torque up to 13.200 Nm



TENBEX-ECO

Nominal torque up to 40.000 Nm



SGFlex-3F

Nominal torque up to 3.200 Nm



SCFusion-SC

electromagnetic switchable clutch
Nominal torque 400 - 12.000 Nm



Technical changes & technical data
 We reserve the right to make technical changes in the course of further development.
 The technical data in the tables as well as on the drawings and datasheets only serve to describe the product and are not to be understood as a guaranteed characteristic in legal terms. All illustrations are only provided as examples.

Disclaimer
 SGF makes every effort to always keep its offering up to date, substantially correct and complete. Nevertheless, the occurrence of errors cannot be completely ruled out.

SGF accepts no liability for the currency, substantial correctness or completeness of the information contained in this document, except when the errors have occurred due to intent or gross negligence. This concerns possible damages of a pecuniary or non-pecuniary nature suffered by third parties caused by the use of the products we offer.

Installation and commissioning of flexible couplings may be performed solely by qualified personnel. We expressly point out that this document can only provide support and that the customer has responsibility for the configuration and operational safety of the total system.

Copyright
 All rights reserved.
 All content, such as text, images, graphics or videos, as well as their arrangement, are subject to copyright protection.

Contact
 For additional information about the product range and special designs or services (vibratory behaviour of a total system calculations for screw connections, etc.), please contact:

Industry@sgf.com

SGF LOCATIONS AND AGENCIES WORLDWIDE



SGF GmbH & Co. KG
 Craslitzer Str. 14
 84478 Waldkraiburg
 GERMANY



Riddhi Engineering Company

www.couplings-mounts.com
sales@riddhiengineeringco.com
 +91 74900 32784