

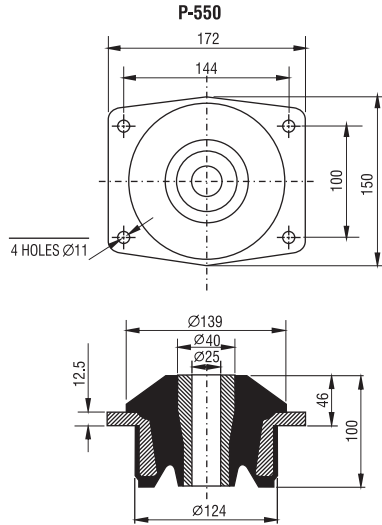

CORE MOUNT P-550



Moulding Innovation into Global Bonds



PART NO.	LOAD (Kg)	DEFLECTION (mm)
P – 550	700	12.0
P – 550	1000	12.0
P – 550	1400	12.0

Rugged construction
 Fail-safe when used with overload and rebound washers
 Capable of withstanding high degree of shocks and vibrations
 High strength flange with cast steel material for P-550

